



Parameter Reference Guide

Digitax M753

Regeneration Mode

About Parameter Reference Guide

The manufacturer accepts no liability for any consequences resulting from inappropriate, negligent or incorrect installation or adjustment of the optional operating parameters of the equipment or from mismatching the variable speed drive with the motor.

The contents of this guide are believed to be correct at the time of printing. In the interests of a commitment to a policy of continuous development and improvement, the manufacturer reserves the right to change the specification of the product or its performance, or the contents of the guide, without notice.

All rights reserved. No parts of this guide may be reproduced or transmitted in any form or by any means, electrical or mechanical including photocopying, recording or by an information storage or retrieval system, without permission in writing from the publisher.

Copyright © September 2018 Control Techniques Ltd
Issue Number: 01.19.00 (EtherCAT 01.03.05)

Digitax M753 Firmware Version: V01.19.00.00
Slot 3 (EtherCAT) Firmware Version: V01.03.05.02

Digitax M753 Project Last Modified: 30-Aug-2018 15:58:03
Slot 3 (EtherCAT) Project Last Modified: 16-Oct-2017 18:01:51

HTML Generator Version: 3.4.3.23943

Parameter mm.000

Parameter mm.000 (mm.000) is one parameter that can be accessed from every drive menu so that the user can initiate various actions by setting a value in this parameter and then performing a drive reset. If the action is completed successfully parameter mm.000 is cleared when the action is complete. If the action is not started because the value does not correspond to an action, or because the action is not allowed (i.e. an attempt is made to load defaults and the drive is enabled), parameter mm.000 is not cleared. If the action is started and then fails a trip is produced and parameter mm.000 is not cleared.

There could be some conflict between the actions of *Parameter mm.000* (mm.000) and *Parameter Cloning* (11.042) when the drive is reset. If *Parameter Cloning* (11.042) has a value of 1 or 2 and a valid action is required from the value of parameter mm.000 then only the action required by parameter mm.000 is performed, but on successful completion of the action both parameters are cleared. If *Parameter Cloning* (11.042) has any other value it is not affected.

The table below shows the possible actions that can be initiated with *Parameter mm.000* (mm.000).

Parameter mm.000 (mm.000) value	Action	Possible failures
1000	Save drive user save parameters to non-volatile memory. Power-down save parameters are saved when the drive enters the under voltage state.	No action if the drive is in the under voltage state (i.e. <i>Under Voltage Active</i> (10.016)), or <i>Low Under Voltage Threshold Select</i> (06.067) =1 or <i>Backup Supply Mode Enable</i> (06.068) = 1 or <i>User Supply Select</i> (06.072).
1001	Save drive parameters to non-volatile memory. It should be noted that power-down save parameters are also saved which will result in one background task scan being extended to 100ms.	
1070	Reset all option modules	
1233	Load 50Hz defaults	No action if the drive is enabled
1234	Load 50Hz defaults to all menus except option module menus (i.e 15 to 20 and 24 to 28)	No action if the drive is enabled
1244	Load 60Hz defaults	No action if the drive is enabled
1245	Load 60Hz defaults to all menus except option module menus (i.e 15 to 20 and 24 to 28)	No action if the drive is enabled
1253	Change drive mode and load 50Hz defaults	No action if the drive is enabled
1254	Change drive mode and load 60Hz defaults	No action if the drive is enabled
1255	Change drive mode and load 50Hz defaults except for menus 15 to 20 and 24 to 28	No action if the drive is enabled
1256	Change drive mode and load 60Hz defaults except for menus 15 to 20 and 24 to 28	No action if the drive is enabled
1299	Reset <i>Stored HF</i> trip.	
2001	Create a boot file on a non-volatile media card based on the present drive parameters including all Menu 20 parameters	Non-volatile media card trips
4xxx	NV media card: Transfer the drive parameters to parameter file xxx	Non-volatile media card trips
5xxx	NV media card: Transfer the onboard user program to onboard user program file xxx	Non-volatile media card trips
6xxx	NV media card: Load the drive parameters from parameter file xxx or the onboard user program from onboard user program file xxx	No action if the drive is enabled Non-volatile media card trips
7xxx	NV media card: Erase file xxx	Non-volatile media card trips
8xxx	NV Media card: Compare the data in the drive with file xxx	Non-volatile media card trips
9555	NV media card: Clear the warning suppression flag	Non-volatile media card trips
9666	NV media card: Set the warning suppression flag	Non-volatile media card trips
9777	NV media card: Clear the read-only flag	Non-volatile media card trips
9888	NV media card: Set the read-only flag	Non-volatile media card trips
9999	NV media card: Erase and format the NV media card	Non-volatile media card trips
110SI	Transfer electronic nameplate data from an encoder into drive parameters. I is the interface: 1=P1 position feedback interface, 2=P2 position feedback interface. S is the source: 0=drive, 1=Option Slot 1, ... 4=Option Slot 4.	If a drive interface is selected (i.e. S = 0): <ul style="list-style-type: none"> If a suitable feedback device is not available then parameter zero will remain at the value set and no action will be taken. If the device does not respond, or there is a comms error or the CRC of the nameplate data is incorrect then a trip is initiated. If an option module interface is selected (i.e. S = 1, 2, 3 or 4): <ul style="list-style-type: none"> If the selected option module is not present or does not support the electronic nameplate function then the system will time out and initiate a trip. If the device does not respond, or there is a comms error or the CRC of the nameplate data is incorrect then a trip is initiated. See <i>Name Plate</i> for more details on the trips.
12000	Only display parameters that are different from their default value. This action does not require a drive reset.	
12001	Only display parameters that are used to set-up destinations (i.e. DE format bit is 1). This action does not require a drive reset.	
59999	Deletes an onboard user program if a program is present. Note: Any parameter changes that have not been saved will be lost during this action.	No action if the drive is enabled. No action if there is no program present. No action if the user program is enabled (i.e. <i>Onboard User Program: Enable</i> (11.047) = 1)
40xxx	If xxx is between 001 and 999 the system is cloned on to an SD card if fitted. This system has been partially implemented, so initiating this process creates the back-up structure on the SD card but does not copy any drive or option module data. Future development is required to complete this function.	No action if the drive is enabled. The drive will trip if the requested back-up data already exists or an option module does not respond correctly during the process.

60xxx	If xxx is between 001 and 999 the system is cloned from an SD card if fitted. This system has not been implemented, but parameter mm.000 is reset if a value between 60001 and 60999 is entered and the drive is reset. Future development is required to complete this function.	No action if the drive is enabled.
-------	--	------------------------------------

Parameter mm.000 (mm.000) values from 1 to 14 are equivalent to other values as shown in the table below to allow easy access to some commonly used functions. For 0 and each of these values the keypad provides a string as shown.

Value	String	Equivalent value	Action
0	[No Action]	0	
1	[Save parameters]	1001	Save drive parameters to non-volatile memory
2	[Load file 1]	6001	Load the data from file 1 on a non-volatile media card into the drive provided it is a parameter file
3	[Save to file 1]	4001	Store the drive parameters in file 1 on a non-volatile media card
4	[Load file 2]	6002	Load the data from file 2 on a non-volatile media card into the drive provided it is a parameter file
5	[Save to file 2]	4002	Store the drive parameters in file 2 on a non-volatile media card
6	[Load file 3]	6003	Load the data from file 3 on a non-volatile media card into the drive provided it is a parameter file
7	[Save to file 3]	4003	Store the drive parameters in file 3 on a non-volatile media card
8	[Show non-default]	12000	Only display parameters that are different from their default value
9	[Destinations]	12001	Only display parameters that are used to set-up destinations
10	[Reset 50Hz defs]	1233	Load 50Hz defaults
11	[Reset 60Hz defs]	1244	Load 60Hz defaults
12	[Reset modules]	1070	Reset all option modules
13	[Read Enc. NP P1]	11001	Encoder electronic nameplate transfer from the encoder connected to drive P1 interface to the drive.
14	[Read Enc. NP P2]	11051	Encoder electronic nameplate transfer from the encoder connected to drive P2 interface to the drive.

Saving drive parameters

User-save and power-down save drive parameters are stored in non-volatile memory within the drive. Any values that have changed are copied to this memory under the following conditions.

Parameter type	Conditions for copy to non-volatile memory
User-save parameter not visible in menu 0	Drive reset with 1000 in <i>Parameter mm.000</i> (mm.000) if the drive is not in the under voltage state and the standard under voltage threshold is being used (i.e. <i>Low Under Voltage Threshold Select</i> (06.067) = 0). OR A drive reset with 1001 in <i>Parameter mm.000</i> (mm.000). OR After parameters are transferred from a non-volatile media card. OR After the drive mode is changed. OR After default parameters are loaded. OR After parameters are transferred from an electronic nameplate.
User save parameter visible in menu 0	Under the conditions given above for user save parameters not visible in Menu 0. OR If the keypad is in edit mode for a user-save parameter in Menu 0, the parameter is saved when the keypad mode is changed from edit mode.
Power-down save parameter	A drive reset with 1000 in <i>Parameter mm.000</i> (mm.000) if the drive is not in the under voltage state and the standard under voltage threshold is being used (i.e. <i>Low Under Voltage Threshold Select</i> (06.067) = 0). OR A drive reset with 1001 in <i>Parameter mm.000</i> (mm.000). OR On the transition into the under voltage state when the standard under voltage threshold is being used (i.e. <i>Low Under Voltage Threshold Select</i> (06.067) is zero). OR After the drive mode is changed. OR After parameters are transferred from a non-volatile media card which results in the drive mode changing.

It can take some time for parameter data to be copied to non-volatile memory, especially if there are a large number of differences between the parameter values in the drive and the values stored in the memory. Saving Power-down save parameters takes a maximum of 300ms, but saving user-save parameters can take several seconds. If the drive is powered from a 24V control supply, or from a low voltage supply, the power down time of the control system can be very short and there is a risk that either the stored values of the power-down save or user-save parameters could be corrupted. This would result in an *EEPROM Fail* trip at the next power-up. To reduce this risk, the power-down save and user-save parameters are each stored in two banks. The banks are alternated each time a save is performed and the bank pointer is only updated once the save is complete. If the new bank is

corrupted a *User Save* or *Power Down Save* is initiated at the next power-up indicating an error in the user-save or power-down save data respectively, and the data from the old bank is used. The following points should be noted:

1. If a *User Save* or *Power Down Save* trip occur at power-up then parameter changes made before power down will be lost. To clear these trips a parameter save must be performed. If both the user-save and power-down save data is corrupted then a *Power Down Save* trip is produced.
2. When a Menu 0 parameter is changed its value is saved immediately to the active bank and the bank pointer is not changed. Therefore changes made via Menu 0 are not lost if a *User Save* trip occurs at power-up.
3. When the drive mode changes all the data in both banks in the non-volatile memory is cleared and the default parameters are saved in both banks. Therefore there is an extended parameter saving period immediately after a drive mode change.
4. Two banks are not provided in non-volatile media cards therefore the card could be corrupted if the power is removed when the drive is writing data to the card.

Loading defaults

A drive reset with 1233 in *Parameter mm.000* (mm.000) loads the defaults defined for each parameter. If defaults are loaded with 1244 in *Parameter mm.000* (mm.000) then the parameters in the table below have different defaults that are intended for the 60Hz regions.

Parameter	Default	Drive modes	Drive voltage rating
Maximum reference clamp (01.006)	60.0Hz	Open-loop	All
Maximum reference clamp (01.006)	1800rpm	RFC-A	All
Standard Ramp Voltage (02.008)	775V	Open-loop, RFC-A, RFC-S	400V
Rated Frequency (05.006)	60.0Hz	Open-loop, RFC-A	All
Rated Load rpm (05.008)	1800rpm	Open-loop	All
Rated Load rpm (05.008)	1770rpm	RFC-A	All
Rated Voltage (05.009)	460V	Open-loop, RFC-A, RFC-S	400V
M2 Maximum Reference Clamp (21.001)	60.0Hz	Open-loop	All
M2 Maximum Reference Clamp (21.001)	1800rpm	RFC-A	All
M2 Rated Frequency (21.006)	60.0Hz	Open-loop, RFC-A	All
M2 Rated Load rpm (21.008)	1800rpm	Open-loop	All
M2 Rated Load rpm (21.008)	1770rpm	RFC-A	All
M2 Rated Voltage (21.009)	460V	Open-loop, RFC-A, RFC-S	All

Non-volatile media card data transfer

Details of the data that can be stored on a non-volatile media card and the methods to transfer/access this data are given in Menu 11.

Stored HF trips

When the drive is subsequently powered up a *Stored HF* trip is initiated where the sub-trip number is the number of the HF trip that last occurred. This trip will occur at every power-up until it is reset. The trip can only be reset by first entering 1299 into *Parameter mm.000* (mm.000). If the drive is powered up and a *Stored HF* trip occurs, *Onboard User Program: Enable* (Pr 11.047) is reset to zero to prevent the on-board user program from running. This ensures that the user program can be changed or erased in case it causes an HF trip at every power-up. Once the *Stored HF* is cleared, it is necessary to power cycle the drive or to re-download the user program to allow the program to restart.

Electronic nameplate

The electronic nameplate is stored in an encoder as a table of bytes as shown in the example below which contains 7 parameter objects.

N1	N0	CRC3	CRC2	CRC1	CRC0	FLG1	FLG0	0xFF	0xFF	0xFF	0xFF	0xFF	0xFF	0xFF	0xFF
M	P	V3	V2	V1	V0	M	P	V3	V2	V1	V0	M	P	V3	V2
V1	V0	M	P	V3	V2	V1	V0	M	P	V3	V2	V1	V0	M	P
V3	V2	V1	V0	M	P	V3	V2	V1	V0						

N1 (MS byte) and N0 (LS byte) gives the number of parameter objects stored in the nameplate. In this example N1=0x00 and N0=0x07.

CRC3 (MS byte) to CRC0 (LS byte) is a 32 bit CRC applied to all bytes in the nameplate except for the number of parameter objects and the CRC. The CRC is generated with a reverse polynomial 0xEDB88320.

FLG1 (MS byte) and FLG0 (LS byte) are assigned for bit flags. At present none of these flags are used, and so these bytes are always zero.

Each parameter object consists of 6 bytes:

M is the menu number between 1 and 41.

P is the parameter number between 0 and 255.

V3 (MS byte) to V0 (LS byte) give a signed 32 bit parameter value. This is equivalent to the largest parameter size used by the drive, and so it can be used to hold the maximum or minimum value of any parameter.

The total size of the nameplate in bytes is the 16 header bytes plus 6 x number of parameter objects.

In an EnDat encoder the nameplate begins at the start of MRS area 0xAB and finishes at the end of MRS area 0xAD. Although not guaranteed, these areas normally both consist of 256 words giving a total size of 1024 bytes. Therefore a nameplate can hold up to $(1024 - 16 (\text{header})) / 6 = 168$ parameter objects. The time to read the nameplate is approximately 60ms per parameter object when *P1 Device Type* (03.038) is SC.EnDat, and 120ms per parameter when *P1 Device Type* (03.038) is EnDat.

In a Hiperface encoder the nameplate can be stored in up to 8 datafields starting at the beginning of datafield 0. The size of datafields can be between 16 and 128 bytes. It is recommended that 128 byte datafields are used, and so the maximum size of the nameplate is 1024 bytes. Therefore a nameplate can hold up to $(1024 - 16 (\text{header})) / 6 = 168$ parameter objects. The time to read the nameplate is approximately 100ms per parameter object.

The nameplate can hold any parameters stored in drive menus (i.e. 1 to 41). If the menu and parameter number correspond to a parameter that does not exist or is read-only then the parameter is simply not written and no trip is initiated. If the value of the parameter is out of range for the parameter then the parameter is not written and a no trip is initiated.

Current Ratings

The tables below give the maximum output current ratings, peak current ratings and power ratings for all drive sizes and voltage ratings.

200V Rated Drives

Model	Heavy Duty					Normal Duty				Kc
	Rated Current	Motor Shaft Power		Peak Current Open Loop	Peak Current RFC	Rated Current	Motor Shaft Power		Peak Current	
	A	kW	hp	A	A	A	kW	hp	A	A
01200022	2.2	0.37	0.5	6.6	6.6	2.2	0.37	0.5	6.6	7.333
01200040	4	0.75	1	12	12	4	0.75	1	12	13.333
01200065	6.5	1.1	1.5	19.5	19.5	6.5	1.1	1.5	19.5	21.667
02200090	9	2.2	3	27	27	9	2.2	3	27	30
02200120	12	2.2	3	36	36	12	2.2	3	36	40
03200160	16	4	5	48	48	16	4	5	48	53.333

400V Rated Drives

Model	Heavy Duty					Normal Duty				Kc
	Rated Current	Motor Shaft Power		Peak Current Open Loop	Peak Current RFC	Rated Current	Motor Shaft Power		Peak Current	
	A	kW	hp	A	A	A	kW	hp	A	A
01400015	1.5	0.37	0.75	4.5	4.5	1.5	0.37	0.75	4.5	5
01400030	3	0.75	1.5	9	9	3	0.75	1.5	9	10
01400042	4.2	1.5	2	12.6	12.6	4.2	1.5	2	12.6	14
02400060	6	2.2	3	18	18	6	2.2	3	18	20
02400080	8	3	5	24	24	8	3	5	24	26.667
02400105	10.5	4	5	31.5	31.5	10.5	4	5	31.5	35
03400135	13.5	5.5	7.5	40.5	40.5	13.5	5.5	7.5	40.5	45
03400160	16	7.5	10	48	48	16	7.5	10	48	53.333

Variable Minimum / Maximum Pairs

The descriptions below define the variable minimum/maximum pairs that can be used with parameters when the VM format bit is set. The variable minimum and maximum themselves can be dependent on other parameters, or the drive rating or other conditions as defined. The variable minimum and the variable maximum have a limited range and this is defined for each minimum/maximum pair.

Identifier	VM_AC_VOLTAGE
Description	Range applied to parameters showing a.c. voltage
Units	V
Range of [MIN]	0
Range of [MAX]	0 to 930

VM_AC_VOLTAGE[MAX] in drive voltage rating dependent. See the table below.

Voltage level	200V	400V	575V	690V
VM_AC_VOLTAGE[MAX]	325	650	780	930

VM_AC_VOLTAGE[MIN] = 0

Identifier	VM_AC_VOLTAGE_SET
Description	Range applied to a.c. voltage set-up parameters
Units	V
Range of [MIN]	0
Range of [MAX]	0 to 765

VM_AC_VOLTAGE_SET[MAX] is drive voltage rating dependent. See the table below.

Voltage level	200V	400V	575V	690V
VM_AC_VOLTAGE_SET[MAX]	265	530	635	765

VM_AC_VOLTAGE_SET[MIN] = 0

Identifier	VM_ACCEL_RATE
Description	Maximum applied to the ramp rate parameters
Units	s/100Hz, s/1000rpm, s/1000mm/s
Range of [MIN]	Open-loop: 0.0 RFC-A, RFC-S: 0.000
Range of [MAX]	Open-loop: 0.0 to 3200.0 RFC-A, RFC-S: 0.000 to 3200.000

A maximum needs to be applied to the ramp rate parameters because the units are a time for a change of speed from zero to a defined level or to maximum speed. The defined level is 100Hz for Open-loop mode and 1000rpm or 1000mm/s for RFC-A and RFC-S modes. If the change of speed is to the maximum speed then changing the maximum speed changes the actual ramp rate for a given ramp rate parameter value. The variable maximum calculation ensures that longest ramp rate (parameter at its maximum value) is not slower than the rate with the defined level, i.e. 3200.00 s / Hz for Open-loop mode, and 3200.000 s / 1000rpm or 3200.000 s / 1000mm/s for RFC-A and RFC-S modes.

The maximum frequency/speed is taken from *Maximum Reference Clamp* (01.006) if *Select Motor 2 Parameters* (11.045) = 0, or *M2 Maximum Reference Clamp* (21.001) if *Select Motor 2 Parameters* (11.045) = 1.

Open-loop mode

VM_ACCEL_RATE[MIN] = 0.0

If *Ramp Rate Units* (02.039) = 0:

VM_ACCEL_RATE[MAX] = 3200.0

Otherwise:

VM_ACCEL_RATE[MAX] = 3200.0 x Maximum frequency / 100.0

RFC-A, RFC-S modes

VM_ACCEL_RATE[MIN] = 0.000

If *Ramp Rate Units* (02.039) = 0:

VM_ACCEL_RATE[MAX] = 3200.000

Otherwise:

VM_ACCEL_RATE[MAX] = 3200.000 x Maximum speed / 1000.0

Identifier	VM_AMC_JERK_UNIPOLAR
Description	Range applied to the parameters showing the AMC jerk
Units	User units / ms / ms / ms
Range of [MIN]	0
Range of [MAX]	107374.1823

VM_AMC_JERK_UNIPOLAR[MAX] = 107374.1823 / *AMC Auto Resolution Scaling* (31.016)

VM_AMC_JERK_UNIPOLAR[MIN] = 0

Identifier	VM_AMC_POSITION
Description	Range applied to the parameters showing the AMC position
Units	User units
Range of [MIN]	-2147483648
Range of [MAX]	2147483647

VM_AMC_POSITION is modified by *AMC Auto Resolution Scaling* (31.016) and *AMC Roll Over Limit* (31.010). See the table below.

<i>AMC Roll Over Limit</i> (31.010)	= 0	> 0
VM_AMC_POSITION[MAX]	2147483647 / <i>AMC Auto Resolution Scaling</i> (31.016)	<i>AMC Roll Over Limit</i> (31.010) - 1
VM_AMC_POSITION[MIN]	-2147483648 / <i>AMC Auto Resolution Scaling</i> (31.016)	0

Identifier	VM_AMC_POSITION_CAM
Description	Range applied to the parameters showing the AMC cam position
Units	User units
Range of [MIN]	-1073741824
Range of [MAX]	1073741823

VM_AMC_POSITION_CAM is modified by *AMC Auto Resolution Scaling* (31.016) and *AMC Roll Over Limit* (31.010). See the table below.

<i>AMC Roll Over Limit</i> (31.010)	= 0	> 0
VM_AMC_POSITION_CAM[MAX]	1073741823 / <i>AMC Auto Resolution Scaling</i> (31.016)	<i>AMC Roll Over Limit</i> (31.010) - 1
VM_AMC_POSITION_CAM[MIN]	-1073741824 / <i>AMC Auto Resolution Scaling</i> (31.016)	- <i>AMC Roll Over Limit</i> (31.010) + 1

Identifier	VM_AMC_POSITION_CAM_UNIPOLAR
Description	Unipolar version of VM_AMC_POSITION_CAM
Units	User units
Range of [MIN]	0
Range of [MAX]	1073741823

VM_AMC_POSITION_CAM_UNIPOLAR is modified by *AMC Auto Resolution Scaling* (31.016) and *AMC Roll Over Limit* (31.010). See the table below.

<i>AMC Roll Over Limit</i> (31.010)	= 0	> 0
VM_AMC_POSITION_CAM_UNIPOLAR[MAX]	1073741823 / <i>AMC Auto Resolution Scaling</i> (31.016)	<i>AMC Roll Over Limit</i> (31.010) - 1
VM_AMC_POSITION_CAM_UNIPOLAR[MIN]	0	0

Identifier	VM_AMC_POSITION_REF
Description	Range applied to the AMC position reference
Units	User units
Range of [MIN]	-2147483648
Range of [MAX]	2147483647

VM_AMC_POSITION_REF is modified by *AMC Auto Resolution Scaling* (31.016), *AMC Roll Over Limit* (31.010) and *AMC Rotary Mode* (34.005). See the table below.

<i>AMC Roll Over Limit</i> (31.010)	= 0	> 0	> 0
<i>AMC Rotary Mode</i> (34.005)	Not active	< 4	= 4
VM_AMC_POSITION_REF[MAX]	2147483647 / <i>AMC Auto Resolution Scaling</i> (31.016)	<i>AMC Roll Over Limit</i> (31.010) - 1	1073741823 / <i>AMC Auto Resolution Scaling</i> (31.016)
VM_AMC_POSITION_REF[MIN]	-2147483648 / <i>AMC Auto Resolution Scaling</i> (31.016)	0	-1073741824 / <i>AMC Auto Resolution Scaling</i> (31.016)

Identifier	VM_AMC_POSITION_UNIPOLAR
Description	Unipolar version of VM_AMC_POSITION
Units	User units
Range of [MIN]	0
Range of [MAX]	2147483647

VM_AMC_POSITION_UNIPOLAR is modified by *AMC Auto Resolution Scaling* (31.016) and *AMC Roll Over Limit* (31.010). See the table below.

<i>AMC Roll Over Limit</i> (31.010)	= 0	> 0
VM_AMC_POSITION_UNIPOLAR[MAX]	2147483647 / <i>AMC Auto Resolution Scaling</i> (31.016)	<i>AMC Roll Over Limit</i> (31.010) - 1
VM_AMC_POSITION_UNIPOLAR[MIN]	0	0

Identifier	VM_AMC_RATE
Description	Range applied to the parameters showing the AMC acceleration
Units	User units / ms / ms
Range of [MIN]	1073742.824
Range of [MAX]	1073741.823

VM_AMC_RATE_UNIPOLAR[MAX] = 1073741.823 / AMC Auto Resolution Scaling (31.016)

VM_AMC_RATE_UNIPOLAR[MIN] = -1073741.824 / AMC Auto Resolution Scaling (31.016)

Identifier	VM_AMC_RATE_UNIPOLAR
Description	Unipolar version of VM_AMC_RATE
Units	User units / ms / ms
Range of [MIN]	0
Range of [MAX]	1073741.823

VM_AMC_RATE_UNIPOLAR[MAX] = 1073741.823 / AMC Auto Resolution Scaling (31.016)

VM_AMC_RATE_UNIPOLAR[MIN] = 0

Identifier	VM_AMC_ROLLOVER
Description	Maximum applied to the AMC Rollover parameter
Units	User units
Range of [MIN]	0
Range of [MAX]	1073741823

VM_AMC_ROLLOVER[MAX] = 1073741823 / AMC Auto Resolution Scaling (31.016)

VM_AMC_ROLLOVER[MIN] = 0

Identifier	VM_AMC_SPEED
Description	Range applied to the parameters showing the AMC speed
Units	User units / ms
Range of [MIN]	-21474836.48
Range of [MAX]	21474836.47

VM_AMC_SPEED[MAX] = 21474836.47 / AMC Auto Resolution Scaling (31.016)

VM_AMC_SPEED[MIN] = -21474836.48 / AMC Auto Resolution Scaling (31.016)

Identifier	VM_AMC_SPEED_UNIPOLAR
Description	Unipolar version of VM_AMC_SPEED
Units	User units / ms
Range of [MIN]	0
Range of [MAX]	21474836.47

VM_SPEED_UNIPOLAR[MAX] = 21474836.47 / AMC Auto Resolution Scaling (31.016)

VM_SPEED_UNIPOLAR[MIN] = 0

Identifier	VM_DC_VOLTAGE
Description	Range applied to d.c. voltage reference parameters
Units	V
Range of [MIN]	0
Range of [MAX]	0 to 1190

VM_DC_VOLTAGE[MAX] is the full scale d.c. link voltage feedback (over voltage trip level) for the drive. This level is drive voltage rating dependent. See the table below.

Voltage level	200V	400V	575V	690V
VM_DC_VOLTAGE[MAX]	415	830	990	1190

VM_DC_VOLTAGE[MIN] = 0

Identifier	VM_DC_VOLTAGE_SET
Description	Range applied to d.c. voltage reference parameters
Units	V
Range of [MIN]	0
Range of [MAX]	0.0 to 1150.0

VM_DC_VOLTAGE_SET[MAX] is drive voltage rating dependent. All values are shown in the table below.

Voltage level	200V	400V	575V	690V
VM_DC_VOLTAGE_SET[MAX]	400	800	955	1150

VM_DC_VOLTAGE_SET[MIN] = 0

Identifier	VM_DRIVE_CURRENT
Description	Range applied to parameters showing current in A
Units	A
Range of [MIN]	-99999.999 to 0.000
Range of [MAX]	0.000 to 99999.999

VM_DRIVE_CURRENT[MAX] is equivalent to the full scale (over current trip level) for the drive and is given by *Full Scale Current Kc* (11.061).

VM_DRIVE_CURRENT[MIN] = - VM_DRIVE_CURRENT[MAX]

Identifier	VM_DRIVE_CURRENT_UNIPOLAR
Description	Unipolar version of VM_DRIVE_CURRENT
Units	A
Range of [MIN]	0.000
Range of [MAX]	0.000 to 99999.999

VM_DRIVE_CURRENT_UNIPOLAR[MAX] = VM_DRIVE_CURRENT[MAX]

VM_DRIVE_CURRENT_UNIPOLAR[MIN] = 0.000

Identifier	VM_HIGH_DC_VOLTAGE
Description	Range applied to the parameters showing high d.c. voltage
Units	V
Range of [MIN]	0
Range of [MAX]	0 to 1500

VM_HIGH_DC_VOLTAGE[MAX] = 1500. This is the full scale d.c. link voltage feedback for the high d.c. link voltage measurement which can measure the voltage if it goes above the normal full scale value.

VM_HIGH_DC_VOLTAGE[MIN] = 0

Identifier	VM_LOW_UNDER_VOLTS
Description	Range applied to the low under voltage threshold
Units	V
Range of [MIN]	24
Range of [MAX]	24 to 1150

If *Back-up Mode Enable* (06.068) = 0

VM_LOW_UNDER_VOLTS[MAX] = VM_STD_UNDER_VOLTS[MIN]

Otherwise

VM_LOW_UNDER_VOLTS[MAX] = VM_STD_UNDER_VOLTS[MIN] / 1.1.

VM_LOW_UNDER_VOLTS[MIN] = 0.

Identifier	VM_MIN_SWITCHING_FREQUENCY
Description	Range applied to the minimum switching frequency parameter
Units	User units
Range of [MIN]	0
Range of [MAX]	0 to 6

VM_MIN_SWITCHING_FREQUENCY[MAX] = *Maximum Switching Frequency* (05.018)

VM_MIN_SWITCHING_FREQUENCY[MIN] = 0 for motor control modes, or 1 for Regen mode (subject to the maximum)

Identifier	VM_MOTOR1_CURRENT_LIMIT
Description	Range applied to current limit parameters (motor 1)
Units	%
Range of [MIN]	0.0
Range of [MAX]	0.0 to 1000.0

VM_MOTOR1_CURRENT_LIMIT[MAX] is dependent on the drive rating and motor set-up parameters.

VM_MOTOR1_CURRENT_LIMIT[MIN] = 0.00

Identifier	VM_MOTOR2_CURRENT_LIMIT
Description	Range applied to current limit parameters (motor 2)
Units	%
Range of [MIN]	0.0
Range of [MAX]	0.0 to 1000.0

VM_MOTOR2_CURRENT_LIMIT[MAX] is dependent on the drive rating and motor set-up parameters.

VM_MOTOR2_CURRENT_LIMIT[MIN] = 0.0

Identifier	VM_NEGATIVE_REF_CLAMP1
Description	Limits applied to the negative frequency or speed clamp (motor 1)
Units	Open-loop: Hz RFC-A, RFC-S: rpm or mm/s
Range of [MIN]	Open-loop: -599.0 to 0.0 RFC-A, RFC-S: -550 x 60 / Motor pole pairs to 0.0
Range of [MAX]	Open-loop: 0.0 to 599.0 RFC-A, RFC-S: 0.0 to 550 x 60 / Motor pole pairs

This variable maximum/minimum defines the range of the negative frequency or speed clamp associated with motor map 1 (*Minimum Reference Clamp* (01.007)). The minimum and maximum are affected by the settings of the *Negative Reference Clamp Enable* (01.008), *Bipolar Reference Enable* (01.010) and *Maximum Reference Clamp* (01.006) as shown in the table below.

<i>Negative Reference Clamp Enable</i> (01.008)	<i>Bipolar Reference Enable</i> (01.010)	VM_NEGATIVE_REF_CLAMP1[MIN]	VM_NEGATIVE_REF_CLAMP1[MAX]
0	0	0.0	Pr 01.006
0	1	0.0	0.0
1	X	-VM_POSITIVE_REF_CLAMP[MAX]	0.0

Identifier	VM_NEGATIVE_REF_CLAMP2
Description	Limits applied to the negative frequency or speed clamp (motor 2)
Units	Open-loop: Hz RFC-A, RFC-S: rpm or mm/s
Range of [MIN]	Open-loop: -599.0 to 0.0 RFC-A, RFC-S: -550 x 60 / Motor pole pairs to 0.0
Range of [MAX]	Open-loop: 0.0 to 599.0 RFC-A, RFC-S: 0.0 to 550 x 60 / Motor pole pairs

This variable maximum/minimum defines the range of the negative frequency or speed clamp associated with motor map 2 (*M2 Minimum Reference Clamp* (21.002)). It is defined in the same way as VM_NEGATIVE_REF_CLAMP1 except that the *M2 Maximum Reference Clamp* (21.001) is used instead of *Maximum Reference Clamp* (01.006).

Identifier	VM_POSITIVE_REF_CLAMP1
Description	Limits applied to the positive frequency or speed reference clamp
Units	Open-loop: Hz RFC-A, RFC-S: rpm or mm/s
Range of [MIN]	Open-loop: 0.0 RFC-A, RFC-S: 0.0
Range of [MAX]	Open-loop: 0.0 to 599.0 RFC-A, RFC-S: 0.0 to 550 x 60 / Motor pole pairs

VM_POSITIVE_REF_CLAMP1[MAX] defines the range of the positive reference clamp, *Maximum Reference Clamp* (01.006), which in turn limit the references. In RFC-A and RFC-S modes an additional limit is applied so that the position feedback does not exceed the speed where the drive can no longer interpret the feedback signal correctly as given in the table below. The limit is based on the position feedback device selected with *Motor Control Feedback Select* (03.026). It is possible to disable this additional limit if the *RFC Feedback Mode* (03.024) ≥ 1 , so that the motor can be operated at a speed above the level where the drive can interpret the feedback in sensorless mode. It should be noted that the position feedback device itself may have a maximum speed limit that is lower than those given in the table. Care should be taken not to exceed a speed that would cause damage to the position feedback device.

Feedback device	VM_POSITIVE_REF_CLAMP1[MAX]
AB, AB Servo	(500kHz x 60 / rotary lines per revolution) rpm (500kHz x linear line pitch in mm) mm/s
FD, FR, FD Servo, FR Servo	(500kHz x 60 / rotary lines per revolution)/2 rpm (500kHz x linear line pitch in mm)/2 mm/s
SC, SC Hiper, SC EnDat, SC SSI, SC Servo	(500kHz x 60 / sine waves per revolution) rpm (500kHz x linear line pitch in mm) mm/s
Resolver	30000 rpm* (250Hz x pole pitch in mm) mm/s
Any other device	50000.0 rpm or mm/s*

*Note that even though these are shown as fixed values they are subject to the maximum of 550 x 60 / Motor Pole Pairs, as are all the other values in this table.

The limit ensures that the frequency of incremental digital or sine wave signals from the encoder do not exceed 500kHz and the modulation frequency for a resolver does not exceed 1kHz, neglecting any speed controller overshoot. The position feedback resolution remains fixed over the whole frequency for digital signals, but reduces with increased frequency or reduced voltage with sine wave signals. The position resolution with sine wave signals is given by the equations below.

Position resolution for a rotary device = K x sine waves per revolution

Position resolution for a linear device = K x sine waves per pole pitch

The value of K varies with the frequency and magnitude of the sine wave signals. The nominal value of K is 1024, and the drive interface provides at least this resolution with 1.0Vp-p sine waves up to a frequency of 50kHz. The table below shows the variation of K with sine wave peak to peak voltage and frequency.

	1kHz	5kHz	50kHz	100kHz	200kHz	500kHz
1.2Vp-p	2048	2048	1024	1024	512	512
1.0Vp-p	2048	2048	1024	512	512	128
0.8Vp-p	1024	1024	1024	512	256	128
0.6Vp-p	1024	1024	512	512	256	128
0.4Vp-p	512	512	512	256	128	64

VM_POSITIVE_REF_CLAMP1[MIN] = 0.0

VM_POSITIVE_REF_CLAMP2[MAX] defines the range of the positive reference clamp, *M2 Maximum Reference Clamp* (21.001), which in turn limit the references. See VM_POSITIVE_REF_CLAMP1 for more details.

Identifier	VM_POWER
Description	Range applied to parameters that either set or display power
Units	kW
Range of [MIN]	-99999.999 to 0.000
Range of [MAX]	0.000 to 99999.999

VM_POWER[MAX] is rating dependent and is chosen to allow for the maximum power that can be output by the drive with maximum a.c. output voltage, at maximum controlled current and unity power factor.

$VM_POWER[Max] = \sqrt{3} \times VM_AC_VOLTAGE[Max] \times VM_DRIVE_CURRENT[Max] / 1000$

VM_POWER[MIN] = -VM_POWER[MAX]

Identifier	VM_RATED_CURRENT
Description	Range applied to rated current parameters
Units	A
Range of [MIN]	0.000
Range of [MAX]	0.000 to 99999.999

VM_RATED_CURRENT [MAX] = *Maximum Rated Current* (11.060) and is dependent on the drive rating.

VM_RATED_CURRENT [MIN] = 0.000

Identifier	VM_REGEN_REACTIVE
Description	Range applied to the reactive current reference in Regen mode
Units	%
Range of [MIN]	-1000.0 to 0.0
Range of [MAX]	0.0 to 1000.0

VM_REGEN_REACTIVE[MAX] applies a limit to the reactive current reference in Regen mode so that the total current reference does not exceed its maximum allowed level.

VM_REGEN_REACTIVE[MIN] = - VM_REGEN_REACTIVE[MAX]

Identifier	VM_SPEED
Description	Range applied to parameters showing speed
Units	Open-loop, RFC-A, RFC-S: rpm or mm/s
Range of [MIN]	Open-loop, RFC-A, RFC-S: -50000.0 to 0.0
Range of [MAX]	Open-loop, RFC-A, RFC-S: 0.0 to 50000.0

This variable minimum/maximum defines the range of speed monitoring parameters. To allow headroom for overshoot the range is set to twice the range of the speed references.

$$VM_SPEED[MIN] = 2 \times VM_SPEED_FREQ_REF[MIN]$$

$$VM_SPEED[MAX] = 2 \times VM_SPEED_FREQ_REF[MAX]$$

Identifier	VM_SPEED_FREQ_KEYPAD_REF
Description	Range applied to the keypad reference
Units	Open-loop: Hz RFC-A, RFC-S: rpm or mm/s
Range of [MIN]	Open-loop: -599.0 to 599.0 RFC-A, RFC-S: -550 x 60 / Motor pole pairs to 550 x 60 / Motor pole pairs
Range of [MAX]	Open-loop: 0.0 to 5990.0 RFC-A, RFC-S: 0.0 to 550 x 60 / Motor pole pairs

This variable maximum is applied to *Keypad Control Mode Reference* (01.017). The maximum applied to these parameters is the same as other frequency reference parameters.

$$VM_SPEED_FREQ_USER_REFS [MAX] = VM_SPEED_FREQ_REF[MAX]$$

However the minimum is dependent on *Negative Reference Clamp Enable* (01.008) and *Bipolar Reference Enable* (01.010).

Negative Reference Clamp Enable (01.008)	Bipolar Reference Enable (01.010)	VM_SPEED_FREQ_USER_REFS[MIN]
0	0	If <i>Select Motor 2 Parameters</i> (11.045) = 0 <i>Minimum Reference Clamp</i> (01.007), otherwise <i>M2 Minimum Reference Clamp</i> (21.002)
0	1	-VM_SPEED_FREQ_REF[MAX]
1	0	0.0
1	1	-VM_SPEED_FREQ_REF[MAX]

Identifier	VM_SPEED_FREQ_REF
Description	Range applied to the frequency or speed reference parameters
Units	Open-loop: Hz RFC-A, RFC-S: rpm or mm/s
Range of [MIN]	Open-loop: -599.0 to 0.0 RFC-A, RFC-S: -550 x 60 / Motor pole pairs to 0.0
Range of [MAX]	Open-loop: 0.0 to 599.0 RFC-A, RFC-S: 0.0 to 550 x 60 / Motor pole pairs

This variable minimum/maximum is applied throughout the frequency and speed reference system so that the references can vary in the range from the minimum to maximum clamps.

Negative Reference Clamp Enable (01.008)	VM_SPEED_FREQ_REF[MAX] if Select Motor 2 Parameters (11.045) = 0	VM_SPEED_FREQ_REF[MAX] if Select Motor 2 Parameters (11.045) = 1
0	<i>Maximum Reference Clamp</i> (01.006)	<i>M2 Maximum Reference Clamp</i> (21.001)
1	<i>Maximum Reference Clamp</i> (01.006) or <i>Minimum Reference Clamp</i> (01.007) whichever the larger	<i>M2 Maximum Reference Clamp</i> (21.001) or <i>M2 Minimum Reference Clamp</i> (21.002) whichever the larger

$$VM_SPEED_FREQ_REF[MIN] = -VM_SPEED_FREQ_REF[MAX].$$

Identifier	VM_SPEED_FREQ_REF_UNIPOLAR
Description	Unipolar version of VM_SPEED_FREQ_REF
Units	Open-loop: Hz RFC-A, RFC-S: rpm or mm/s
Range of [MIN]	Open-loop: 0.0 RFC-A, RFC-S: 0.0
Range of [MAX]	Open-loop: 0.0 to 599.0 RFC-A, RFC-S: 0.0 to 550 x 60 / Motor pole pairs

$$VM_SPEED_FREQ_REF_UNIPOLAR[MAX] = VM_SPEED_FREQ_REF[MAX]$$

$$VM_SPEED_FREQ_REF_UNIPOLAR[MIN] = 0.0$$

Identifier	VM_SPEED_FREQ_USER_REFS
Description	Range applied to analogue reference parameters
Units	Open-loop: Hz RFC-A, RFC-S: rpm or mm/s
Range of [MIN]	Open-loop: -599.00 to 599.00 RFC-A, RFC-S: -550 x 60 / Motor pole pairs to 550 x 60 / Motor pole pairs
Range of [MAX]	Open-loop: 0.0 to 599.00 RFC-A, RFC-S: 0.0 to 550 x 60 / Motor pole pairs

This variable maximum is applied to *Analogue Reference 1* (01.036) and *Analogue Reference 2* (01.037). It should be noted that in Open-loop mode the analogue reference parameters have two decimal places.

The maximum applied to these parameters is the same as other frequency reference parameters.

$$VM_SPEED_FREQ_USER_REFS [MAX] = VM_SPEED_FREQ_REF[MAX]$$

However the minimum is dependent on *Negative Reference Clamp Enable* (01.008) and *Bipolar Reference Enable* (01.010).

<i>Negative Reference Clamp Enable</i> (01.008)	<i>Bipolar Reference Enable</i> (01.010)	VM_SPEED_FREQ_USER_REFS[MIN]
0	0	If <i>Select Motor 2 Parameters</i> (11.045) = 0 <i>Minimum Reference Clamp</i> (01.007), otherwise <i>M2 Minimum Reference Clamp</i> (21.002)
0	1	-VM_SPEED_FREQ_REF[MAX]
1	0	0.0
1	1	-VM_SPEED_FREQ_REF[MAX]

Identifier	VM_STD_UNDER_VOLTS
Description	Range applied to the standard under voltage threshold
Units	V
Range of [MIN]	0 to 1150
Range of [MAX]	0 to 1150

$$VM_STD_UNDER_VOLTS[MAX] = VM_DC_VOLTAGE_SET / 1.1$$

VM_STD_UNDER_VOLTS[MIN] is voltage rating dependent. See the table below.

Voltage level	200V	400V	575V	690V
VM_STD_UNDER_VOLTS[MIN]	175	330	435	435

Identifier	VM_SUPPLY_LOSS_LEVEL
Description	Range applied to the supply loss threshold
Units	V
Range of [MIN]	0 to 1150
Range of [MAX]	0 to 1150

$$VM_SUPPLY_LOSS_LEVEL[MAX] = VM_DC_VOLTAGE_SET[MAX]$$

VM_SUPPLY_LOSS_LEVEL[MIN] is drive voltage rating dependent. See the table below.

Voltage level	200V	400V	575V	690V
VM_SUPPLY_LOSS_LEVEL[MIN]	205	410	540	540

Identifier	VM_SWITCHING_FREQUENCY
Description	Range applied to the maximum switching frequency parameters
Units	User units
Range of [MIN]	0
Range of [MAX]	0 to 6

$$VM_SWITCHING_FREQUENCY[MAX] = \text{Power stage dependent}$$

VM_SWITCHING_FREQUENCY[MIN] = 0 for motor control modes, or 1 for Regen mode (subject to the maximum)

Identifier	VM_TORQUE_CURRENT
Description	Range applied to torque and torque producing current parameters. (Where this is used in Regen mode it refers to the active current.)
Units	%
Range of [MIN]	-1000.0 to 0.0
Range of [MAX]	0.0 to 1000.0

Select Motor 2 Parameters (11.045)	VM_TORQUE_CURRENT[MAX]
0	VM_MOTOR1_CURRENT_LIMIT[MAX]
1	VM_MOTOR2_CURRENT_LIMIT[MAX]

VM_TORQUE_CURRENT[MIN] = -VM_TORQUE_CURRENT[MAX]

Identifier	VM_TORQUE_CURRENT_UNIPOLAR
Description	Unipolar version of VM_TORQUE_CURRENT
Units	%
Range of [MIN]	0.0
Range of [MAX]	0.0 to 1000.0

VM_TORQUE_CURRENT_UNIPOLAR[MAX] = VM_TORQUE_CURRENT[MAX]

VM_TORQUE_CURRENT_UNIPOLAR[MIN] = 0.0

Identifier	VM_USER_CURRENT
Description	Range applied to torque reference and percentage load parameters with one decimal place
Units	%
Range of [MIN]	-1000.0 to 0.0
Range of [MAX]	0.0 to 1000.0

VM_USER_CURRENT[MAX] = *User Current Maximum Scaling* (04.024)

VM_USER_CURRENT[MIN] = -VM_USER_CURRENT[MAX]

Identifier	VM_USER_CURRENT_HIGH_RES
Description	Range applied to torque reference and percentage load parameters with two decimal places
Units	%
Range of [MIN]	-1000.00 to 0.00
Range of [MAX]	0.00 to 1000.00

VM_USER_CURRENT_HIGH_RES[MAX] = *User Current Maximum Scaling* (04.024) with an additional decimal place

VM_USER_CURRENT_HIGH_RES[MIN] = -VM_USER_CURRENT_HIGH_RES[MAX]

Menu 1 Single Line Descriptions – Regen References

Mode: Regeneration

Parameter		Range				Default				Type	
RW	Read / Write	RO	Read-only	Bit	Bit parameter	Txt	Text string	Date	Date parameter	Time	Time parameter
Chr	Character parameter	Bin	Binary parameter	IP	IP address	Mac	MAC address	Ver	Version number	SMP	Slot, menu, parameter
Num	Number parameter	DE	Destination	ND	No default value	RA	Rating dependent	NC	Non-copyable	PT	Protected
FI	Filtered	US	User save	PS	Power-down save						

Menu 1 – Regen References

Mode: Regeneration

Menu 3 Single Line Descriptions – Regen Control

Mode: Regeneration

Parameter		Range	Default	Type					
03.001	Reactive Power	±VM_POWER kVAr		RO	Num	ND	NC	PT	FI
03.004	Regen Synchronisation Mode	Re-synchronise (0), Delayed Trip (1), Trip (2), Auto-synchronise (3)	Re-synchronise (0)	RW	Txt				US
03.005	Voltage Set Point	±VM_DC_VOLTAGE_SET V	200V drive: 350 V 400V drive: 700 V 575V drive: 835 V 690V drive: 1100 V	RW	Num		RA		US
03.006	Voltage Controller Proportional Gain Kp	0 to 65535	4000	RW	Num				US
03.007	Disable Charge System / Close Contactor	Off (0) or On (1)		RO	Bit	ND	NC	PT	
03.008	Charge System Disabled / Contactor Closed	Off (0) or On (1)		RO	Bit	ND	NC		
03.009	Synchronised	Off (0) or On (1)		RO	Bit	ND	NC	PT	
03.010	Power Input 1	±100.0 %	0.0 %	RW	Num		NC		
03.011	Current Trim Mode	0 to 1	0	RW	Num				US
03.012	Power Input Mode	Off (0) or On (1)	Off (0)	RW	Bit				US
03.013	Power Input 2	±100.0 %	0.0 %	RW	Num		NC		
03.014	Power Input 3	±100.0 %	0.0 %	RW	Num		NC		
03.015	Power Input 1 Scaling	0.000 to 4.000	1.000	RW	Num				US
03.016	Power Input 2 Scaling	0.000 to 4.000	1.000	RW	Num				US
03.017	Power Input 3 Scaling	0.000 to 4.000	1.000	RW	Num				US
03.018	Power Input kW	±VM_POWER kW	0.000 kW	RW	Num		RA		
03.019	Reactive Power Input Mode	Off (0) or On (1)	Off (0)	RW	Bit				US
03.020	Reactive Power Input kVAR	±VM_POWER kVAr	0.000 kVAr	RW	Num		RA		US
03.021	Harmonic Reduction Enable	Disabled (0), Imbalance Only (1), All (2)	Imbalance Only (1)	RW	Txt				US
03.022	Voltage Ramp Time	0.1 to 100.0 V/ms	1.0 V/ms	RW	Num				US
03.023	Regen Supply Loss a.c. Level	±VM_AC_VOLTAGE_SET V	200V drive: 75 V 400V drive: 150 V 575V drive: 225 V 690V drive: 225 V	RW	Num		RA		US
03.024	Regen Minimum Frequency	10 to 200 Hz	40 Hz	RW	Num				US
03.025	Regen Maximum Frequency	10 to 200 Hz	70 Hz	RW	Num				US
03.026	Regen Minimum Voltage	±VM_AC_VOLTAGE V	0 V	RW	Num		RA		US
03.027	Regen Maximum Voltage	±VM_AC_VOLTAGE V	0 V	RW	Num		RA		US
03.028	Supply Voltage	±VM_AC_VOLTAGE_SET V	200V drive: 230 V 400V drive 50Hz: 400 V 400V drive 60Hz: 460 V 575V drive: 575 V 690V drive: 690 V	RW	Num		RA		US
03.029	Supply Voltage Detection Mode	Measured (0), User (1), User Delayed (2)	User Delayed (2)	RW	Txt				US
03.030	Island Detection Enable	Off (0) or On (1)	Off (0)	RW	Bit				US
03.031	Island Detection Injection Frequency	1Hz (0), 2Hz (1), 4Hz (2)	1Hz (0)	RW	Txt				US
03.032	Island Detection Level	0 to 100 %		RO	Num	ND	NC	PT	
03.033	Island Detection Synchronisation Source Select	Disabled (0), Slot 1 (1), Slot 2 (2), Slot 3 (3), Slot 4 (4)	Disabled (0)	RW	Txt				US
03.034	Island Detect Synchronisation Source	Disabled (0), Slot 1 (1), Slot 2 (2), Slot 3 (3), Slot 4 (4)		RO	Txt	ND	NC	PT	
03.035	Synchronisation Headroom	0.0 to 25.0 %	5.0 %	RW	Num				US
03.036	Estimated Supply Voltage	±VM_AC_VOLTAGE V		RO	Num	ND	NC	PT	
03.037	Positive Phase Sequence Volts	±VM_AC_VOLTAGE V		RO	Num	ND	NC	PT	FI
03.038	Negative Phase Sequence Volts	±VM_AC_VOLTAGE V		RO	Num	ND	NC	PT	FI
03.039	Negative Phase Sequence Current Gain	0.00 to 1.00	0.05	RW	Num				US

RW	Read / Write	RO	Read-only	Bit	Bit parameter	Txt	Text string	Date	Date parameter	Time	Time parameter
Chr	Character parameter	Bin	Binary parameter	IP	IP address	Mac	MAC address	Ver	Version number	SMP	Slot, menu, parameter
Num	Number parameter	DE	Destination	ND	No default value	RA	Rating dependent	NC	Non-copyable	PT	Protected
FI	Filtered	US	User save	PS	Power-down save						

Menu 3 – *Regen Control*

Mode: Regeneration

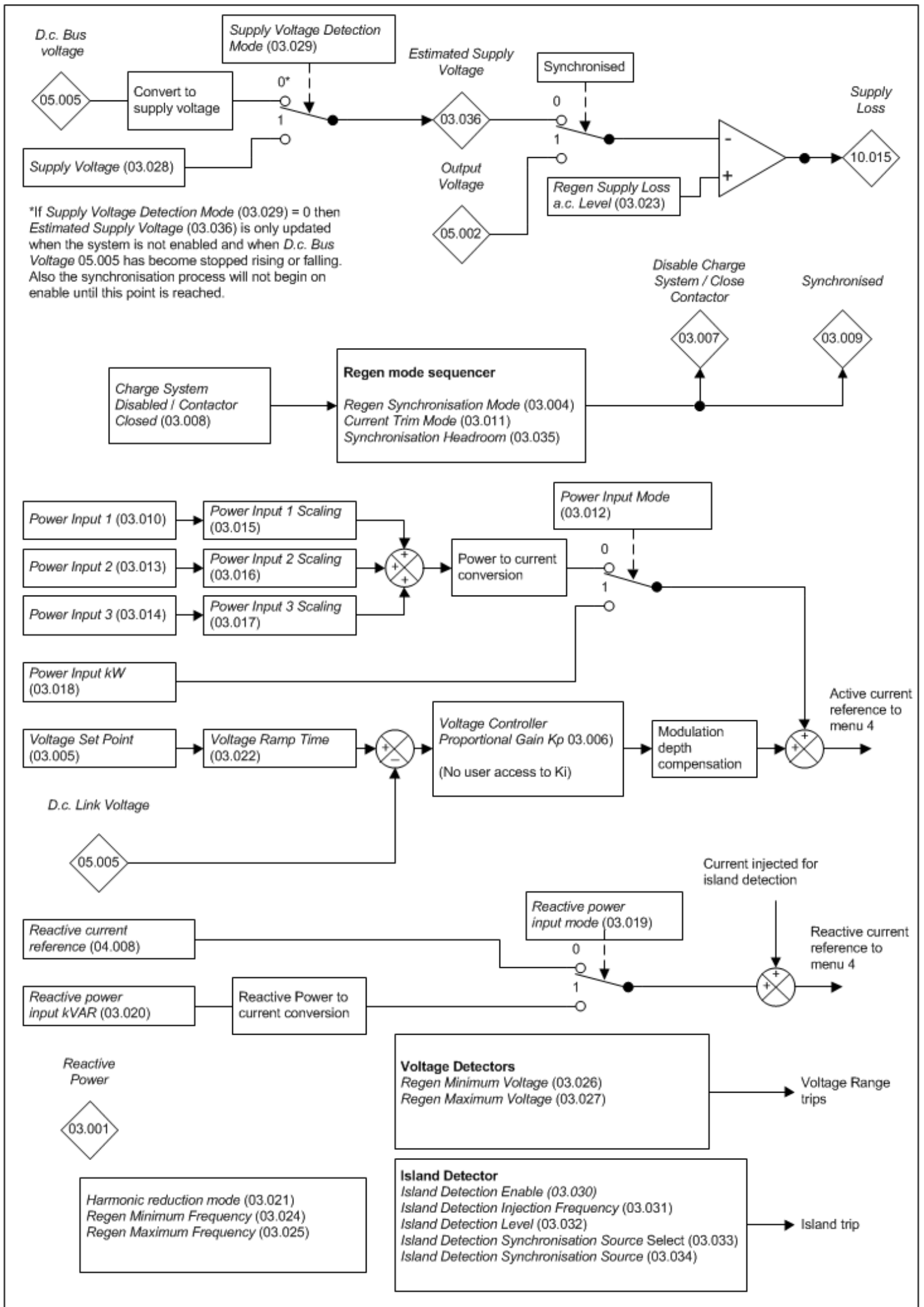

Parameter	03.001 Reactive Power		
Short description			
Mode	Regeneration		
Minimum	-VM_POWER	Maximum	VM_POWER
Default		Units	kVAr
Type	32 Bit Volatile	Update Rate	Background write
Display Format	Standard	Decimal Places	3
Coding	RO, FI, VM, ND, NC, PT		

Output Power (05.003) and *Reactive Power* (03.001) are the power and VAR's respectively that flow from the supply to the drive. When *Reactive Power* (03.001) is positive the phase current flowing from the supply to the drive contains a component that lags the respective phase voltage, and so the regen system appears like an inductance connected to the supply and imports VARs. When *Reactive Power* (03.001) is negative the phase current flowing from the supply contains a component which leads the respective phase voltage, and so the regen system appears like a capacitance connected to the supply and exports VARs.

Parameter	03.004 Regen Synchronisation Mode		
Short description	Regen Synchronisation Mode		
Mode	Regeneration		
Minimum	0	Maximum	3
Default	0	Units	
Type	8 Bit User Save	Update Rate	Background read
Display Format	Standard	Decimal Places	0
Coding	RW, TE		

Value	Text
0	Re-synchronise
1	Delayed Trip
2	Trip
3	Auto-synchronise

When the system is enabled it attempts to synchronise to the supply. If the supply has significant distortion then the synchronisation process may fail and cause an over-current condition to be detected. The system will automatically reset the detected over-current condition and continue to attempt to synchronise. Once the system is synchronised, then if synchronisation is subsequently lost, or an over-current condition caused by a supply transient occurs, or supply loss is detected (i.e. *Supply Loss* (10.015) = 1), then the action taken is defined by *Regen Synchronisation Mode* (03.004) as given below. (It should be noted that the over-current condition will only be reset automatically ten times in any 10s period before an *OI ac* trip is produced.)

0: Re-synchronise

If supply loss is detected the system will attempt to re-synchronise when the supply loss condition is no longer active. If an over-current trip occurs the system will attempt to re-synchronise. If *Supply Voltage Detection Mode* (03.029) = 0 or 2 re-synchronisation will only begin if *D.c. Bus Voltage* (05.005) has stopped rising or falling. For *Supply Voltage Detection Mode* (03.029) = 0, this is so the supply voltage can be estimated from the level of the d.c. link voltage. If *Supply Voltage Detection Mode* (03.029) = 1 rapid re-synchronisation is possible because the system does not wait for the d.c. link voltage to stop falling before attempting to re-synchronise.

1: Delayed Trip

The system operates in the same way as "Re-synchronise" mode except that a *Line Sync* trip is initiated if synchronisation takes more than 30s.

2: Immediate Trip

The system operates in the same way as "Re-synchronise" mode except that a *Line Sync* trip is initiated if synchronisation takes more than 30s, and *Line Sync* trip is produced immediately if supply loss is detected while the system is synchronised.

3: Auto-synchronise

If an over-current condition is detected then this is reset. The system will simulate the supply angle based on the supply conditions before the over-current condition and restart the system within 10ms.

If supply loss is detected the system will simulate the supply angle based on the supply conditions before supply loss was detected. This allows the inverter to remain active during the supply loss period and it is possible for reactive current to flow into the supply in the normal way, but the active current is held at zero. As the active current is held at zero the d.c. link must be held at the required level externally, therefore this mode is only suitable for an application where an external system connected to the d.c. terminals and holds the d.c. voltage at a suitable level. *Regen Supply Loss a.c. Level* (03.023) should be set to a level that is higher than the likely voltage seen at the inverter terminals due to any current being fed into the supply (e.g. 10% of nominal supply voltage) or else the system will attempt to synchronise to its own output voltage. If *Supply Loss* (10.015) remains active for more than 2.0s then an *Island.2* trip is initiated. The diagram below shows the timing and minimum voltage envelope for auto-synchronisation. If the required timing and voltage for transient fault ride-through lies within this envelope then the auto-synchronisation can be used to meet the requirements.

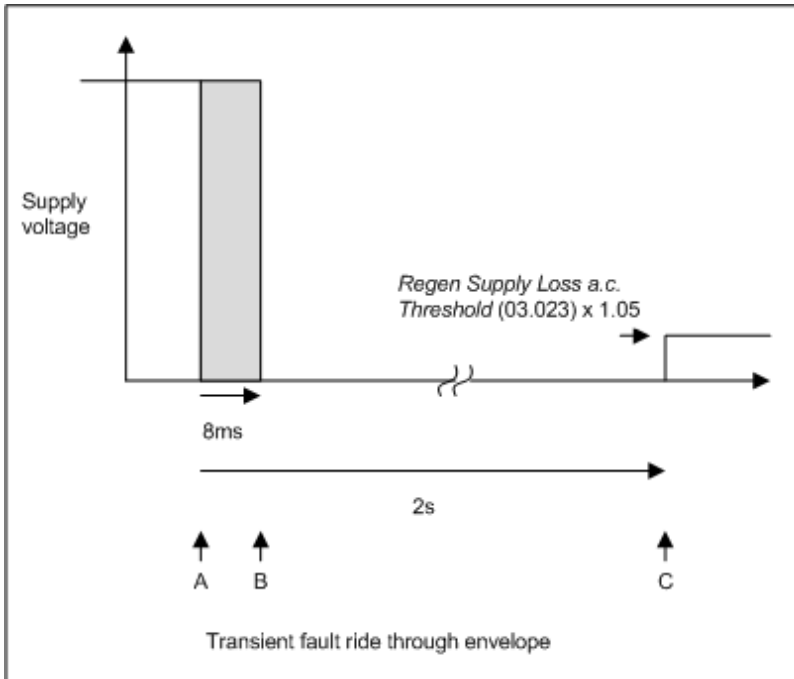

At point 'A' the fault occurs and the voltage falls below *Regen Supply Loss a.c. Level* (03.023). During the period from point 'A' to point 'B' the regen system does not allow either active or reactive power to flow to/from the supply. The maximum time between point 'A' and point 'B' is 8ms, but this may be shorter depending on the size of the current transient caused by the fault. If the current transient exceeds the over-current threshold then the system will take 8ms to recover, otherwise there is no delay and the regen system will remain active throughout the fault. From point 'B' to point 'C', where the supply voltage remains below *Regen Supply Loss a.c. Level* (03.023) x 1.05, auto-synchronisation is active and it is possible to request reactive power flow either using *Reactive Power Input kVAR* (03.020) or *Reactive Current Reference* (04.008). During this period active power flow is not possible as it is disabled by the regen system. If the supply voltage remains below *Regen Supply Loss a.c. Level* (03.023) x 1.05 for more than 2s the regen system will trip. Once the supply voltage has risen above *Regen Supply Loss a.c. Level* (03.023) x 1.05 auto-synchronisation is disabled and active power flow is re-enabled. The request for reactive and active power must be made by the user during supply transient ride-through. It is also likely that the supply voltage recovery characteristic envelope must lie within the envelope given and that additional supply voltage monitoring will be required to take action if the required recover does not occur.

Parameter	03.005 Voltage Set Point		
Short description			
Mode	Regeneration		
Minimum	-VM_DC_VOLTAGE_SET	Maximum	VM_DC_VOLTAGE_SET
Default	See exceptions below	Units	V
Type	16 Bit User Save	Update Rate	4ms read
Display Format	Standard	Decimal Places	0
Coding	RW, VM, RA		

Voltage	Default Value
200V	350
400V	700
575V	835
690V	1100

The regen drive attempts to hold the d.c. bus voltage at the level specified by *Voltage Set Point* (03.005). The *Voltage Set Point* (03.005) must always be higher than the peak of the line to line supply voltage if the unit is to operate correctly. The default values can be used with most supplies giving a reasonable level of control headroom. However, with higher voltage supplies the set-point must be raised.

Parameter	03.006 Voltage Controller Proportional Gain Kp		
Short description			
Mode	Regeneration		
Minimum	0	Maximum	65535
Default	4000	Units	
Type	16 Bit User Save	Update Rate	Background read
Display Format	Standard	Decimal Places	0
Coding	RW, BU		

The d.c. bus voltage is controlled by a PI controller, which provides the reference for the real component of current from the inverter terminals to the supply. The power input parameters (*Power Input 1* (03.010), *Power Input 2* (03.013), *Power Input 3* (03.014) or *Power Input kW* (03.018)) are provided to give a power feed forward term, at the output of the PI controller, from the motor drives connected to the d.c. bus. If possible the power feed forwards should be used so that the PI controller is simply providing a trim to the d.c. bus voltage. In most cases the default voltage controller gains can be used, however the effect of the gains and the response of the voltage controller is discussed below.

For the purpose of analysing the voltage controller response it is assumed that a power feed-forward term is not provided. If the power flow from the d.c. bus is increased (i.e. motor is accelerated by a motor drive connected to the d.c. bus) the d.c. bus voltage will fall, but the minimum level will be limited to just below the peak rectified level of the supply provided the maximum rating of the unit is not exceeded. If the power flow to the d.c. bus is increased (i.e. motor is decelerated by a motor drive connected to the d.c. bus) the d.c. bus voltage will rise. If the peak of the d.c. bus voltage reaches the over voltage level the regen drive will trip. A rapid transient where power into the d.c. bus is increased is shown below.

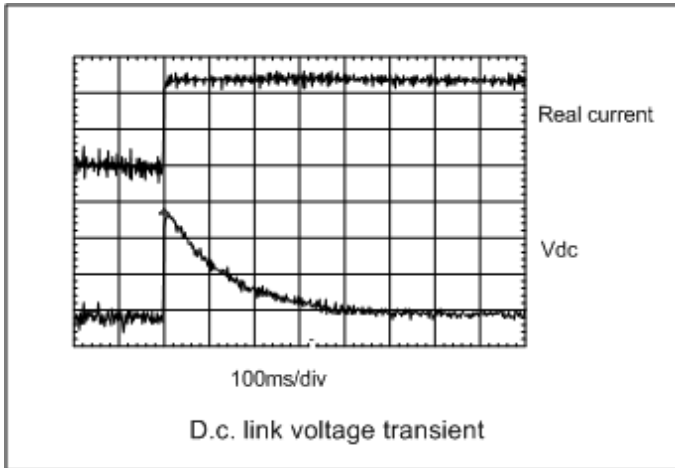

The example shown is for a very rapid load change where the torque reference of the motor drive has been changed instantly from one value to another. The peak of the resulting transient is

$$\Delta V_{dc} = 191680 \times P_d / (v_{ll} \times K_p \times K_c) \text{ Volts}$$

and the time constant of the recovery is $K_p / 30520$ seconds.

where:

P_d is the transient change of power flow

v_{ll} is the line to line supply voltage

K_p = Voltage Controller Proportional Gain K_p (03.006)

K_c = Full Scale Current K_c (11.061)

For example, if $P_d=7.5\text{kW}$, $v_{ll}=400\text{V}$, $K_p=4000$, $K_c=38.222\text{A}$ then $\Delta V_{dc}=23.5\text{V}$ and the time constant is 131ms.

In the example given there is a very rapid change of power flow. The transient d.c. bus voltage change can be substantially reduced by introducing a time constant into the power transient. For example a filter could be included between the speed controller and current controller in the motor drive with *Current Reference Filter 1 Time Constant* (04.012). A time constant of 20ms reduces the voltage transient by 25% and a time constant of 40ms reduces the voltage transient by 50%. In most cases it is not desirable to reduce the performance of the motor drive, and so as already mentioned the best solution is to use a power feed forward term from the motor drive.

So far the discussion has been related to the d.c. bus voltage controller gain, however, the controller provides the real current reference to the regen drive current controllers, and so the current controller gains affect the response of the voltage controller. If the default voltage controller gain is used and it is possible to obtain a stable response from the current controllers with their default gains then the voltage controller response will be stable. However, in some cases it will be necessary to reduce the current controller gains to make these controllers stable, in which case it is likely that the voltage controller gain will need to be reduced to make this controller stable.

It is possible to disable the d.c. bus voltage controller. See *Active Current Reference Selector* (04.010). It should be noted that if *Voltage Controller Proportional Gain K_p* (03.006) is set to zero, this will disable the proportional term of the PI controller that controls the d.c. bus voltage, but not the integral term. Therefore *Active Current Reference Selector* (04.010) should be used to disable the d.c. bus voltage controller.

Parameter	03.007 Disable Charge System / Close Contactor		
Short description			
Mode	Regeneration		
Minimum	0	Maximum	1
Default		Units	
Type	1 Bit Volatile	Update Rate	4ms write
Display Format	Standard	Decimal Places	0
Coding	RO, ND, NC, PT		

In Regen mode some form of charging system must be used to limit the current taken from the supply to charge the d.c. bus capacitors when the supply is first connected to the inverter terminals (i.e. UVW). An external soft start resistor or the thyristor charging system in the drive may be used. The regen mode sequencer provides an output which should be used to disable or enable the charge system (*Disable Charge System / Close Contactor* (03.007)). This should be routed to a digital output, so that when *Disable Charge System / Close Contactor* (03.007) = 0 the charge system is connected between the supply and the regen system, and when *Disable Charge System / Close Contactor* (03.007) = 1 the charge system is bypassed and the inverter terminals are connected to the supply. This is demonstrated by the simplified charge system diagram below. It should be noted that this is used to show the connections required between the charge system and the drive, and does not show a complete power circuit.

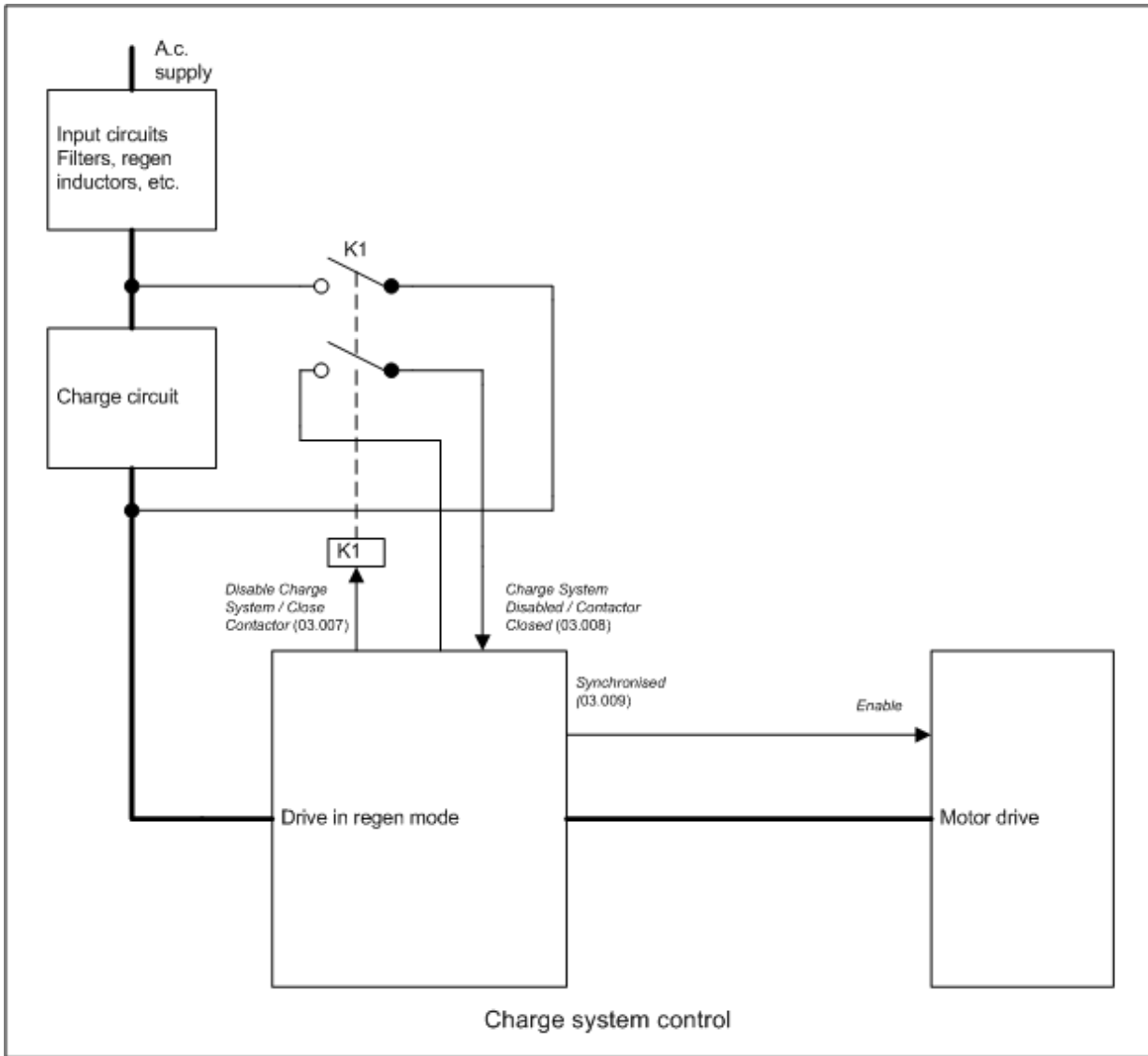

It is possible that the charge circuit could be damaged if the motor drive is active while the charge circuit has not been bypassed or disconnected. To prevent damage from occurring, the state of the charge system should be passed to *Charge System Disabled / Contactor Closed* (03.008) via a digital input so that the Regen system can monitor the actual charge system state. It is also necessary to pass an indication of the state of the charge system and the Regen system to the motor drive. The "synchronised" indication is used to enable the motor drive, so that it will only be enabled when the charge system is disabled and the regen system is enabled and fully synchronised.

The Motor Drive is always disabled unless the charge circuit has been bypassed and the Regen drive is synchronised, however it is possible to use auto-synchronisation (*Regen Synchronisation Mode* (03.004) = 3) with a motor drive set up for supply loss ride-through to keep both the Regen Drive and the Motor Drive active during a short supply loss. The connection between the drives should be as follows.

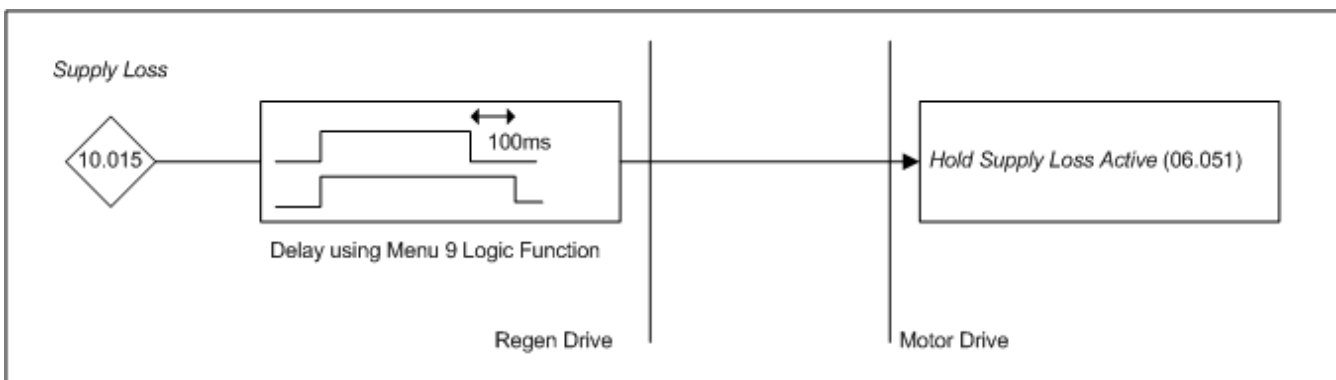

When the supply loss occurs the Regen drive will stay active and indicate to the Motor Drive that supply must stay active until 100ms after the supply has recovered. When the d.c. link voltage falls to the supply loss level defined by *Supply Loss Detection Level* (06.048) in the Motor Drive then this drive will go into supply loss mode and control the d.c. link voltage by taking power from the motor and load. When the supply recovers the Regen Drive will control the d.c. link voltage and force it to rise above the supply loss control level. The Motor Drive will stay in supply loss mode and not take power from the supply until 100ms later when the system can operate normally again.

Parameter	03.008 Charge System Disabled / Contactor Closed		
Short description			
Mode	Regeneration		
Minimum	0	Maximum	1
Default		Units	
Type	1 Bit Volatile	Update Rate	4ms read
Display Format	Standard	Decimal Places	0
Coding	RO, ND, NC		

See *Disable Charge System / Close Contactor* (03.007).

Parameter	03.009 Synchronised		
Short description	Regen system is synchronised to the supply		
Mode	Regeneration		
Minimum	0	Maximum	1
Default		Units	
Type	1 Bit Volatile	Update Rate	4ms write
Display Format	Standard	Decimal Places	0
Coding	RO, ND, NC, PT		

See *Disable Charge System / Close Contactor* (03.007).

Parameter	03.010 Power Input 1		
Short description			
Mode	Regeneration		
Minimum	-100.0	Maximum	100.0
Default	0.0	Units	%
Type	16 Bit Volatile	Update Rate	250µs read
Display Format	Standard	Decimal Places	1
Coding	RW, NC		

Power feed-forward compensation can be used to reduce the transient d.c. bus voltage produced when a fast load transient occurs on a drive connected to the d.c. terminals of the regen drive. If *Power Output* (07.033) from a motor drive is routed to an analogue output with unity scaling it will produce full scale output when the power is equal to $3 \times (VM_DC_VOLTAGE[MAX] / 2\sqrt{2}) \times Full\ Scale\ Current\ Kc$ (11.061). If this signal is connected to an analogue input on the regen drive, the input is routed to *Power Input 1* (03.010) and *Power Input 1 Scaling* (03.015) is set to the ratio of the current scaling values for the motor drive and regen drives (i.e. Motor drive *Full Scale Current Kc* (11.061) / Regen drive *Full Scale Current Kc* (11.061)) then the correct power feed-forward term will be provided. The default value for *Power Input 1 Scaling* (03.015) is 1.000, and so unless the regen and motor drives are the same size this parameter will need to be adjusted.

Up to 3 motor drives connected to the regen drive d.c. terminals can use this system to provide power feed-forward as each of the power inputs are summed to give the final power feed-forward term. (It should be noted that a maximum of two analogue inputs are provided on the drive with 250µs update rate. If the third input is used the update rate is 4ms, and so this should only be used for a motor drive with limited dynamic performance.) If more motor drives are connected to the d.c. terminals of the regen drive, or a digital power feed-forward system is required, then *Power Input kW* (03.018) should be used. The power in kW can be transferred from each motor drive using fast synchronous communications to an application module in the regen drive. The total power in kW should be calculated by the applications module and then written to the *Power Input kW* (03.018). For the power feed-forward to be effective data should be transferred every 250µs with the minimum delay (i.e. 500µs) and the total power written to *Power Input kW* (03.018) every 250µs.

It should be noted that the polarity of all the power feed-forward parameters is that positive values cause power to flow from the supply and negative values cause power to flow into the supply.

Parameter	03.011 Current Trim Mode		
Short description			
Mode	Regeneration		
Minimum	0	Maximum	1
Default	0	Units	
Type	8 Bit User Save	Update Rate	Background read
Display Format	Standard	Decimal Places	0
Coding	RW		

A current feedback trimming routine runs before the regen drive is enabled to minimise offsets in the current feedback. If *Current Trim Mode* (03.011) = 0 the current offset trim is only carried out once when the drive comes out of the under voltage state and is not repeated unless the supply is removed and reapplied. The current offset trim is only carried out when the charge system is enabled (contactor open) as this minimises current flowing into the inverter terminals due to noise on the supply that may disturb the current offset trimming.

Current Trim Mode (03.011) should be set to one if the current offset trim is required each time when the regen drive is enabled. To ensure that the current offset trim is not disturbed by noise on the supply, the charge system is enabled before the current offset trim and then disabled again before the regen drive goes into its active state. This causes the charge system contactors to switch each time the regen drive is enabled.

Parameter	03.012 Power Input Mode		
Short description			
Mode	Regeneration		
Minimum	0	Maximum	1
Default	0	Units	
Type	1 Bit User Save	Update Rate	Background read
Display Format	Standard	Decimal Places	0
Coding	RW		

If *Power Input Mode* (03.012) = 0 the power feed-forward is provided by the parameters that are intended for use with analogue inputs. If *Power Input Mode* (03.012) = 1 the power feed-forward is provided by *Power Input kW* (03.018).

Parameter	03.013 Power Input 2		
Short description			
Mode	Regeneration		
Minimum	-100.0	Maximum	100.0
Default	0.0	Units	%
Type	16 Bit Volatile	Update Rate	250µs read
Display Format	Standard	Decimal Places	1
Coding	RW, NC		

See *Power Input 1* (03.010).

Parameter	03.014 Power Input 3		
Short description			
Mode	Regeneration		
Minimum	-100.0	Maximum	100.0
Default	0.0	Units	%
Type	16 Bit Volatile	Update Rate	250µs read
Display Format	Standard	Decimal Places	1
Coding	RW, NC		

See *Power Input 1* (03.010).

Parameter	03.015 Power Input 1 Scaling		
Short description			
Mode	Regeneration		
Minimum	0.000	Maximum	4.000
Default	1.000	Units	
Type	16 Bit User Save	Update Rate	Background read
Display Format	Standard	Decimal Places	3
Coding	RW		

See *Power Input 1* (03.010).

Parameter	03.016 Power Input 2 Scaling		
Short description			
Mode	Regeneration		
Minimum	0.000	Maximum	4.000
Default	1.000	Units	
Type	16 Bit User Save	Update Rate	Background read
Display Format	Standard	Decimal Places	3
Coding	RW		

See *Power Input 1* (03.010).

Parameter	03.017 Power Input 3 Scaling		
Short description			
Mode	Regeneration		
Minimum	0.000	Maximum	4.000
Default	1.000	Units	
Type	16 Bit User Save	Update Rate	Background read
Display Format	Standard	Decimal Places	3
Coding	RW		

See *Power Input 1* (03.010).

Parameter	03.018 Power Input kW		
Short description			
Mode	Regeneration		
Minimum	-VM_POWER	Maximum	VM_POWER
Default	0.000	Units	kW
Type	32 Bit Volatile	Update Rate	250µs read
Display Format	Standard	Decimal Places	3
Coding	RW, VM, RA, NC		

See *Power Input 1* (03.010).

Parameter	03.019 Reactive Power Input Mode		
Short description			
Mode	Regeneration		
Minimum	0	Maximum	1
Default	0	Units	
Type	1 Bit User Save	Update Rate	Background read
Display Format	Standard	Decimal Places	0
Coding	RW		

It is possible to control the reactive component of current from the a.c. terminals of the regen drive. When this component is positive the reactive current flowing from the supply to the regen drive lags the voltage. When this component is negative the reactive current flowing from the supply to the regen drive leads the voltage. Reactive component control can be used even if the d.c. bus voltage controller is active, because the voltage controller only affects the real current component. If *Reactive Power Input Mode* (03.019) = 0 the reactive current can be defined with *Reactive Current Reference* (04.008). If *Reactive Power Input Mode* (03.019) = 1 the reactive kVAR can be specified with *Reactive Power Input kVAR* (03.020).

Parameter	03.020 Reactive Power Input kVAR		
Short description			
Mode	Regeneration		
Minimum	-VM_POWER	Maximum	VM_POWER
Default	0.000	Units	kVAr
Type	32 Bit User Save	Update Rate	250µs read
Display Format	Standard	Decimal Places	3
Coding	RW, VM, RA, NC		

See *Reactive Power Input Mode* (03.019).

Parameter	03.021 Harmonic Reduction Enable		
Short description	Harmonic Reduction Enable		
Mode	Regeneration		
Minimum	0	Maximum	2
Default	1	Units	
Type	8 Bit User Save	Update Rate	Background read
Display Format	Standard	Decimal Places	0
Coding	RW, TE		

Value	Text
0	Disabled
1	Imbalance Only
2	All

Even with the optimum d.c. bus voltage and current controller set-up it is possible for supply voltage distortion to cause harmonic distortion in the a.c. currents between the supply and the regen drive. The regen drive includes an additional system to reduce imbalance, 5th harmonics and 7th harmonics in the a.c. currents. *Harmonic Reduction Enable* (03.021) defines the type of distortion reduction required. It should be noted that the regen system input filter will absorb 5th and 7th harmonic currents if there is 5th or 7th harmonic supply voltage distortion. The regen drive cannot reduce this current, but can minimise the 5th and 7th harmonic current due to 5th and 7th harmonic voltage distortion between the supply and the inverter.

Harmonic Reduction Enable (03.021)	Distortion reduced
0	None
1	Due to voltage imbalance
2	Due to voltage imbalance, 5th and 7th harmonics

If *Harmonic Reduction Enable* (03.021) > 0 then *Phase Loss* (10.081) is set if *Negative Phase Sequence Volts* (03.038) > *Positive Phase Sequence Volts* (03.037) / 2 for more than 100ms. It should be noted that *Phase Loss* (10.081) is only set when the regen drive is active, so if the transient caused by an asymmetrical fault causes the system to trip then *Phase Loss* (10.081) is not set.

Each of the additional controllers used to minimise currents due to imbalance, 5th and 7th harmonic distortion have an integral controller similar to the controller for normal supply frequency currents. The gains for the 5th and 7th harmonic current control are at a fixed low level, however, the gain for minimisation of currents due to imbalance can be adjusted by the user with *Negative Phase Sequence Current Gain* (03.039). The default value is low, and so the response due to a change in supply imbalance is relatively slow. For most applications the gain can be left at the default level, but where a fast response is required, i.e. continued operation in the presence of an asymmetrical fault, the level should be

increased. *Negative Phase Sequence Current Gain* (03.039) defines the gain used for control of currents due to imbalance as a proportion of *Current Controller Ki Gain* (04.014). Care should be taken when increasing this value as the system stability may be reduced particularly with a weak supply.

Parameter	03.022 Voltage Ramp Time		
Short description			
Mode	Regeneration		
Minimum	0.1	Maximum	100.0
Default	1.0	Units	V/ms
Type	16 Bit User Save	Update Rate	Background read
Display Format	Standard	Decimal Places	1
Coding	RW		

When a regen drive is enabled and has synchronised to the supply, the d.c. bus voltage is at a level equal to the peak line to line voltage. The voltage controller is then enabled and attempts to raise the d.c. bus voltage to the set-point defined by *Voltage Set Point* (03.005). The voltage reference is ramped up to the required level at a rate defined by *Voltage Ramp Time* (03.022) in V/ms. The default value of 1.0V/ms ensures limited over-shoot when the d.c. link voltage reaches the required level. If a shorter synchronisation time is required then the ramp rate can be increased, however care must be taken to avoid over-voltage trips particularly if a high level is used for the d.c. link voltage set-point. If a faster ramp rate and high set-point are required it may be necessary the increase *Voltage Controller Proportional Gain Kp* (03.006) to minimise over-shoot.

Parameter	03.023 Regen Supply Loss a.c. Level		
Short description			
Mode	Regeneration		
Minimum	-VM_AC_VOLTAGE_SET	Maximum	VM_AC_VOLTAGE_SET
Default	See exceptions below	Units	V
Type	16 Bit User Save	Update Rate	Background read
Display Format	Standard	Decimal Places	0
Coding	RW, VM, RA		

Voltage	Default Value
200V	75
400V	150
575V	225
690V	225

If the supply voltage falls below *Regen Supply Loss a.c. Level* (03.023) x 0.95 then supply loss is detected and *Supply Loss* (10.015) is set to one. The supply voltage must rise above *Regen Supply Loss a.c. Level* (03.023) x 1.05 to remove the supply loss condition and for *Supply Loss* (10.015) to be reset to zero. When the system is not synchronised *Estimated Supply Voltage* (03.036) is used to represent the supply voltage, but when the system is synchronised the output of the inverter (*Output Voltage* (05.002)) is used.

If *Supply Voltage Detection Mode* (03.029) = 0 (Measured) then *Estimated Supply Voltage* (03.036) is derived from the d.c. link voltage. When the system is not synchronised *Estimated Supply Voltage* (03.036) is set up with a derived value, but only after the d.c. link voltage has stopped rising or falling. This ensures a correct estimate because the supply voltage has stopped causing the d.c. link voltage to rise and the d.c. link voltage is not still falling because the system was previously active. When the system synchronises *Estimated Supply Voltage* (03.036) is left at the value derived before synchronisation and will only be modified again when the system is not synchronised and the d.c. link voltage is stable. It should be noted that if the supply is removed and then re-applied before the d.c. link voltage falls below the under-voltage threshold, it is possible for the transient caused by re-applying the supply to give an indication that the d.c. link voltage is stable. If this occurs the measured d.c. link supply voltage may be higher than the actual supply voltage. As the accuracy of measured supply voltage is not critical in setting up the current controllers etc. this will not generally cause a problem. If it is a problem then *Supply Voltage Detection Mode* (03.029) should be set to a value other than zero, so that the estimated supply voltage can be defined by the user.

If *Supply Voltage Detection Mode* (03.029) = 1 (User) then *Estimated Supply Voltage* (03.036) is set directly from *Supply Voltage* (03.028). This can either be set to a fixed value or it can be controlled from voltage magnitude feedback via an analogue input. When this setting is used the system does not wait for the d.c. link voltage to stop rising or falling, and so resynchronisation is quicker when the supply is restored after a short supply loss, or the system is disabled and then re-enabled rapidly. However, the system will continuously attempt to resynchronise after the supply is removed. It is likely that some transient voltages will occur at the inverter terminals as the d.c. link voltage decays.

If *Supply Voltage Detection Mode* (03.029) = 2 (User Delayed) the system operates in the same way as when *Supply Voltage Detection Mode* (03.029) = 1 (User) except that resynchronisation when the supply is restored after supply loss, or when the system is enabled, does not start until the d.c. link voltage has stopped rising or falling.

As well as being used to give the supply loss condition, *Estimated Supply Voltage* (03.036) is also used to pre-set the current controllers during synchronisation and after the system has automatically reset an over-current condition when synchronised (i.e. when *Regen Synchronisation Mode* (03.004) = 3). During synchronisation the full value of *Estimated Supply Voltage* (03.036) is used to give the minimum current transient. After automatic reset of an over-current condition then *Estimated Supply Voltage* (03.036) / 2 is used because this mode can be used to ride through supply short circuits and the supply voltage may change rapidly between the normal supply voltage and zero. By using half the nominal supply voltage the current transient is minimised for either condition.

Parameter	03.024 Regen Minimum Frequency		
Short description			
Mode	Regeneration		
Minimum	10	Maximum	200
Default	40	Units	Hz
Type	8 Bit User Save	Update Rate	4ms read
Display Format	Standard	Decimal Places	0
Coding	RW, BU		

Frequency limits defined by *Regen Minimum Frequency* (03.024) and *Regen Maximum Frequency* (03.025) are applied to the Regen system output. A margin of 5Hz or more should be allowed outside the likely supply frequency range to enable the Regen system to operate. If the Regen system supply frequency is within approximately 5Hz of either limit for 100ms the system will not remain synchronised and will attempt to re-synchronise. While the supply frequency remains within approximately 5Hz of either limit the system will not be able to synchronise successfully. The frequency limits are important if the supply is removed when the Regen system is active, as the system could remain active, particularly if energy is fed into the d.c. link, with an uncontrolled output frequency and voltage.

Parameter	03.025 Regen Maximum Frequency		
Short description			
Mode	Regeneration		
Minimum	10	Maximum	200
Default	70	Units	Hz
Type	8 Bit User Save	Update Rate	4ms read
Display Format	Standard	Decimal Places	0
Coding	RW, BU		

See *Regen Minimum Frequency* (03.024).

Parameter	03.026 Regen Minimum Voltage		
Short description			
Mode	Regeneration		
Minimum	-VM_AC_VOLTAGE	Maximum	VM_AC_VOLTAGE
Default	0	Units	V
Type	16 Bit User Save	Update Rate	4ms read
Display Format	Standard	Decimal Places	0
Coding	RW, VM, RA		

Supply voltage range detection can be provided. If *Regen Maximum Voltage* (03.027) is set to its default of zero, then additional supply voltage checking is disabled. If *Regen Minimum Voltage* (03.026) is set to any other value and the supply voltage is outside the range defined by *Regen Maximum Voltage* (03.027) and *Regen Minimum Voltage* (03.026) for more than 100ms a *Voltage Range* trip is initiated with sub-trip 1 for a voltage below the minimum threshold or sub-trip 2 for voltage above the maximum threshold. If *Regen Maximum Voltage* (03.027) \leq *Regen Minimum Voltage* (03.026) then the trip is initiated repeatedly.

Parameter	03.027 Regen Maximum Voltage		
Short description			
Mode	Regeneration		
Minimum	-VM_AC_VOLTAGE	Maximum	VM_AC_VOLTAGE
Default	0	Units	V
Type	16 Bit User Save	Update Rate	4ms read
Display Format	Standard	Decimal Places	0
Coding	RW, VM, RA		

See *Regen Minimum Voltage* (03.026).

Parameter	03.028 Supply Voltage		
Short description			
Mode	Regeneration		
Minimum	-VM_AC_VOLTAGE_SET	Maximum	VM_AC_VOLTAGE_SET
Default	See exceptions below	Units	V
Type	16 Bit User Save	Update Rate	4ms read
Display Format	Standard	Decimal Places	0
Coding	RW, VM, RA		

Voltage	Region	Default Value
200V	All	230
400V	50Hz	400
400V	60Hz	460
575V	All	575
690V	All	690

See *Regen Supply Loss a.c. Level* (03.023).

Parameter	03.029 Supply Voltage Detection Mode		
Short description	Supply Voltage Detection Mode		
Mode	Regeneration		
Minimum	0	Maximum	2
Default	2	Units	
Type	8 Bit User Save	Update Rate	Background read
Display Format	Standard	Decimal Places	0
Coding	RW, TE, BU		

Value	Text
0	Measured
1	User
2	User Delayed

See *Regen Supply Loss a.c. Level* (03.023).

Parameter	03.030 Island Detection Enable		
Short description			
Mode	Regeneration		
Minimum	0	Maximum	1
Default	0	Units	
Type	1 Bit User Save	Update Rate	Background read
Display Format	Standard	Decimal Places	0
Coding	RW		

If *Island Detection Enable* (03.030) is set to one then the detection system is enabled and injects a test current with a frequency defined by *Island Detection Injection Frequency* (03.031). The *Island Detection Level* (03.032) shows the detection level with respect to the threshold, and if the level reaches 100% an *Island.1* trip is initiated.

The following should be noted:

1. It is possible that high levels of active current that contain components similar to the injection frequency may cause false detection of an island condition and this is more likely the higher the injection frequency.
2. The detection system will detect an island condition in a time from 3 to 4 cycles of the injection frequency, therefore a higher injection frequency gives faster detection.
3. Changing *Island Detection Injection Frequency* (03.031) while the system is running may cause an *Island.1* trip.

The injection frequency used by the island detection system affects the maximum island detection time as given in the table below:

Injection frequency	Maximum detection time
1Hz	4s
2Hz	2s
4Hz	1s

For the island detection system to comply with IEEE 1547 the detection time must be 2s or less, and so an injection frequency of 2 or 4Hz must be used. For the island detection system to comply with VDE 0126-1-1 the detection time must be 5s or less, and so any of the injection frequencies may be used.

Parameter	03.031 Island Detection Injection Frequency		
Short description			
Mode	Regeneration		
Minimum	0	Maximum	2
Default	0	Units	
Type	8 Bit User Save	Update Rate	Background read
Display Format	Standard	Decimal Places	0
Coding	RW, TE		

Value	Text
0	1Hz
1	2Hz
2	4Hz

See *Island Detection Enable* (03.030).

Parameter	03.032 <i>Island Detection Level</i>		
Short description			
Mode	Regeneration		
Minimum	0	Maximum	100
Default		Units	%
Type	8 Bit Volatile	Update Rate	Background write
Display Format	Standard	Decimal Places	0
Coding	RO, ND, NC, PT		

See *Island Detection Enable* (03.030).

Parameter	03.033 <i>Island Detection Synchronisation Source Select</i>		
Short description	Island Detection Synchronisation Source Select		
Mode	Regeneration		
Minimum	0	Maximum	4
Default	0	Units	
Type	8 Bit User Save	Update Rate	Background Read
Display Format	Standard	Decimal Places	0
Coding	RW, TE		

Value	Text
0	Disabled
1	Slot 1
2	Slot 2
3	Slot 3
4	Slot 4

If *Island Detection Synchronisation Source Select* (03.033) is set to its default value of zero then the frequency of the current injected to detect an island condition is defined by the Regen system. If *Island Detection Synchronisation Source Select* (03.033) is set to a non-zero value to select an option module, and the option module provides a suitable clock, then the injected current is synchronised to the clock. This allows the injected current from a number of Regen systems to be synchronised to a master clock. If the option module does not provide a suitable clock then the frequency is defined by the Regen system. The source being used is given in *Island Detect Synchronisation Source* (03.034).

Parameter	03.034 <i>Island Detect Synchronisation Source</i>		
Short description	Island Detect Synchronisation Source		
Mode	Regeneration		
Minimum	0	Maximum	4
Default		Units	
Type	8 Bit Volatile	Update Rate	Background Write
Display Format	Standard	Decimal Places	0
Coding	RO, TE, ND, NC, PT		

Value	Text
0	Disabled
1	Slot 1
2	Slot 2
3	Slot 3
4	Slot 4

See *Island Detection Synchronisation Source Select* (03.033).

Parameter	03.035 <i>Synchronisation Headroom</i>		
Short description	Synchronisation Headroom		
Mode	Regeneration		
Minimum	0.0	Maximum	25.0
Default	5.0	Units	%
Type	8 Bit User Save	Update Rate	Background Read
Display Format	Standard	Decimal Places	1
Coding	RW, BU		

Each time a synchronisation attempt is made the d.c. link voltage is increased because of current that is built up in the inductors connected between the supply and the regen system. As the current decays energy is transferred from the supply to the d.c. link capacitors, and the energy stored in the inductors is also transferred to the d.c. link capacitors. To prevent an over-voltage trip during synchronisation or re-synchronisation the system will prevent this process from starting if the d.c. link voltage is above the level defined by Maximum d.c. link voltage x *Synchronisation Headroom* (03.035). For example the full scale d.c. link voltage for a 400V drive is 830V, so with the default setting of 5% the d.c. link voltage must be less than 830V x 95% = 788.5V before the synchronisation process will begin. If the recommended components are connected between the supply and the regen system the rise in the d.c. link voltage during synchronisation requires less than 5% headroom. If alternative inductors are used that are significantly larger than the recommended values or the supply inductance is very high it may be necessary to increase the headroom.

Parameter	03.036 <i>Estimated Supply Voltage</i>		
Short description	Estimated Supply Voltage		
Mode	Regeneration		
Minimum	-VM_AC_VOLTAGE	Maximum	VM_AC_VOLTAGE
Default		Units	V
Type	16 Bit Volatile	Update Rate	2ms Write (During Synchronisation)
Display Format	Standard	Decimal Places	0
Coding	RO, VM, ND, NC, PT		

See *Regen Supply Loss a.c. Level* (03.023).

Parameter	03.037 <i>Positive Phase Sequence Volts</i>		
Short description	Positive Phase Sequence Volts		
Mode	Regeneration		
Minimum	-VM_AC_VOLTAGE	Maximum	VM_AC_VOLTAGE
Default		Units	V
Type	16 Bit Volatile	Update Rate	1ms Write
Display Format	Standard	Decimal Places	0
Coding	RO, FI, VM, ND, NC, PT		

The supply voltage at its fundamental frequency can be represented as a combination of positive, negative and zero sequence components. The regen system supply voltage cannot contain any zero sequence components because there is no neutral connection. The negative phase sequence component is an indication of the level of supply imbalance. *Positive Phase Sequence Volts* (03.037) and *Negative Phase Sequence Volts* (03.038) show the positive and negative phase sequence components of voltage at the inverter terminals in r.m.s. line to line Volts. Note that *Negative Phase Sequence Volts* (03.038) is zero unless *Harmonic Reduction Enable* (03.021) > 0.

Parameter	03.038 <i>Negative Phase Sequence Volts</i>		
Short description	Negative Phase Sequence Volts		
Mode	Regeneration		
Minimum	-VM_AC_VOLTAGE	Maximum	VM_AC_VOLTAGE
Default		Units	V
Type	16 Bit Volatile	Update Rate	1ms Write
Display Format	Standard	Decimal Places	0
Coding	RO, FI, VM, ND, NC, PT		

See *Positive Phase Sequence Volts* (03.037).

Parameter	03.039 <i>Negative Phase Sequence Current Gain</i>		
Short description	Negative Phase Sequence Current Gain		
Mode	Regeneration		
Minimum	0.00	Maximum	1.00
Default	0.05	Units	
Type	16 Bit User Save	Update Rate	Background Read
Display Format	Standard	Decimal Places	2
Coding	RW		

See *Harmonic Reduction Enable* (03.021).

Menu 4 Single Line Descriptions – Current Control

Mode: Regeneration

Parameter		Range	Default	Type					
04.001	Current Magnitude	±VM_DRIVE_CURRENT_UNIPOLAR A		RO	Num	ND	NC	PT	FI
04.002	Active Current	±VM_DRIVE_CURRENT A		RO	Num	ND	NC	PT	FI
04.004	Final Active Current Reference	±VM_TORQUE_CURRENT %		RO	Num	ND	NC	PT	FI
04.005	Power From Supply Current Limit	±VM_MOTOR1_CURRENT_LIMIT %	0.0 %	RW	Num		RA		US
04.006	Power To Supply Current Limit	±VM_MOTOR1_CURRENT_LIMIT %	0.0 %	RW	Num		RA		US
04.007	Symmetrical Current Limit	±VM_MOTOR1_CURRENT_LIMIT %	0.0 %	RW	Num		RA		US
04.008	Reactive Current Reference	±VM_REGEN_REACTIVE %	0.0 %	RW	Num				US
04.009	Active Current Reference	±VM_USER_CURRENT %	0.0 %	RW	Num				US
04.010	Active Current Reference Selector	Off (0) or On (1)	Off (0)	RW	Bit				US
04.013	Current Controller Kp Gain	0 to 30000	90	RW	Num				US
04.014	Current Controller Ki Gain	0 to 30000	2000	RW	Num				US
04.015	Inductor Thermal Time Constant	1.0 to 3000.0 s	89.0 s	RW	Num				US
04.017	Reactive Current	±VM_DRIVE_CURRENT A		RO	Num	ND	NC	PT	FI
04.018	Final Current Limit	±VM_TORQUE_CURRENT %		RO	Num	ND	NC	PT	
04.019	Inductor Protection Accumulator	0.0 to 100.0 %		RO	Num	ND	NC	PT	PS
04.020	Percentage Load	±VM_USER_CURRENT %		RO	Num	ND	NC	PT	FI
04.021	Current Feedback Filter Disable	Off (0) or On (1)	Off (0)	RW	Bit				US
04.024	User Current Maximum Scaling	±VM_TORQUE_CURRENT_UNIPOLAR %	175.0 %	RW	Num		RA		US
04.036	Inductor Protection Accumulator Power-up Value	Power down (0), Zero (1), Real time (2)	Power down (0)	RW	Txt				US
04.040	Final Reactive Current Reference	±200.0 %		RO	Num	ND	NC	PT	FI

RW	Read / Write	RO	Read-only	Bit	Bit parameter	Txt	Text string	Date	Date parameter	Time	Time parameter
Chr	Character parameter	Bin	Binary parameter	IP	IP address	Mac	MAC address	Ver	Version number	SMP	Slot, menu, parameter
Num	Number parameter	DE	Destination	ND	No default value	RA	Rating dependent	NC	Non-copyable	PT	Protected
FI	Filtered	US	User save	PS	Power-down save						

Menu 4 – Current Control

Mode: Regeneration

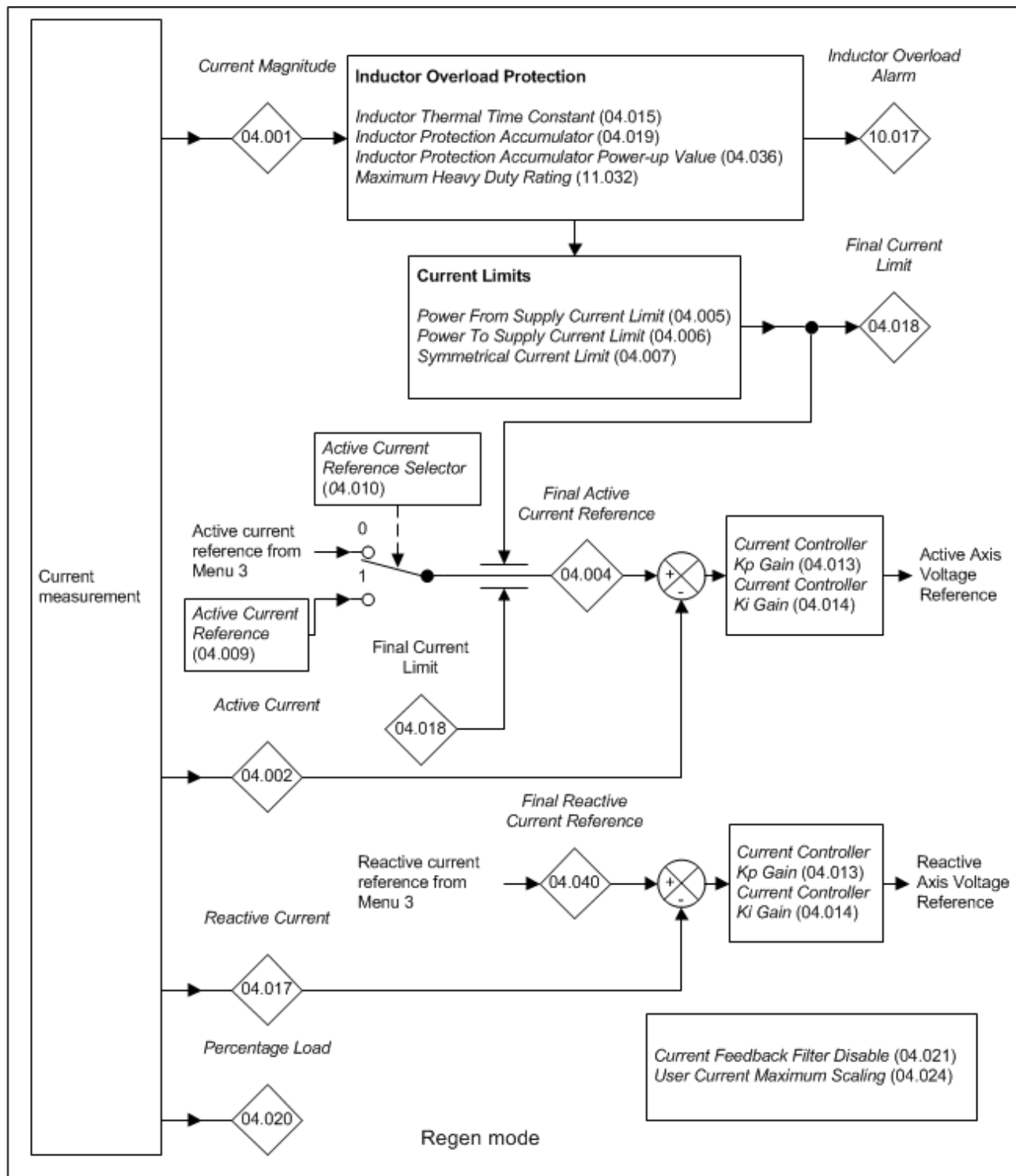

In Regen mode separate current control is provided for the active and reactive currents. The active current reference is normally produced by the d.c. bus voltage controller and power feed-forwards system, although it is possible for the user to define the active current reference if required. The reactive current reference is either defined directly from the *Reactive Current Reference* (04.008) or from the *Reactive Power Input kVAR* (03.020). See Menu 3 for more details.

Drive rating information

Current rating

The drive output currents can be represented as a vector. The limits and the scaling applied to the drive output currents are defined by the magnitude of this vector as shown below.

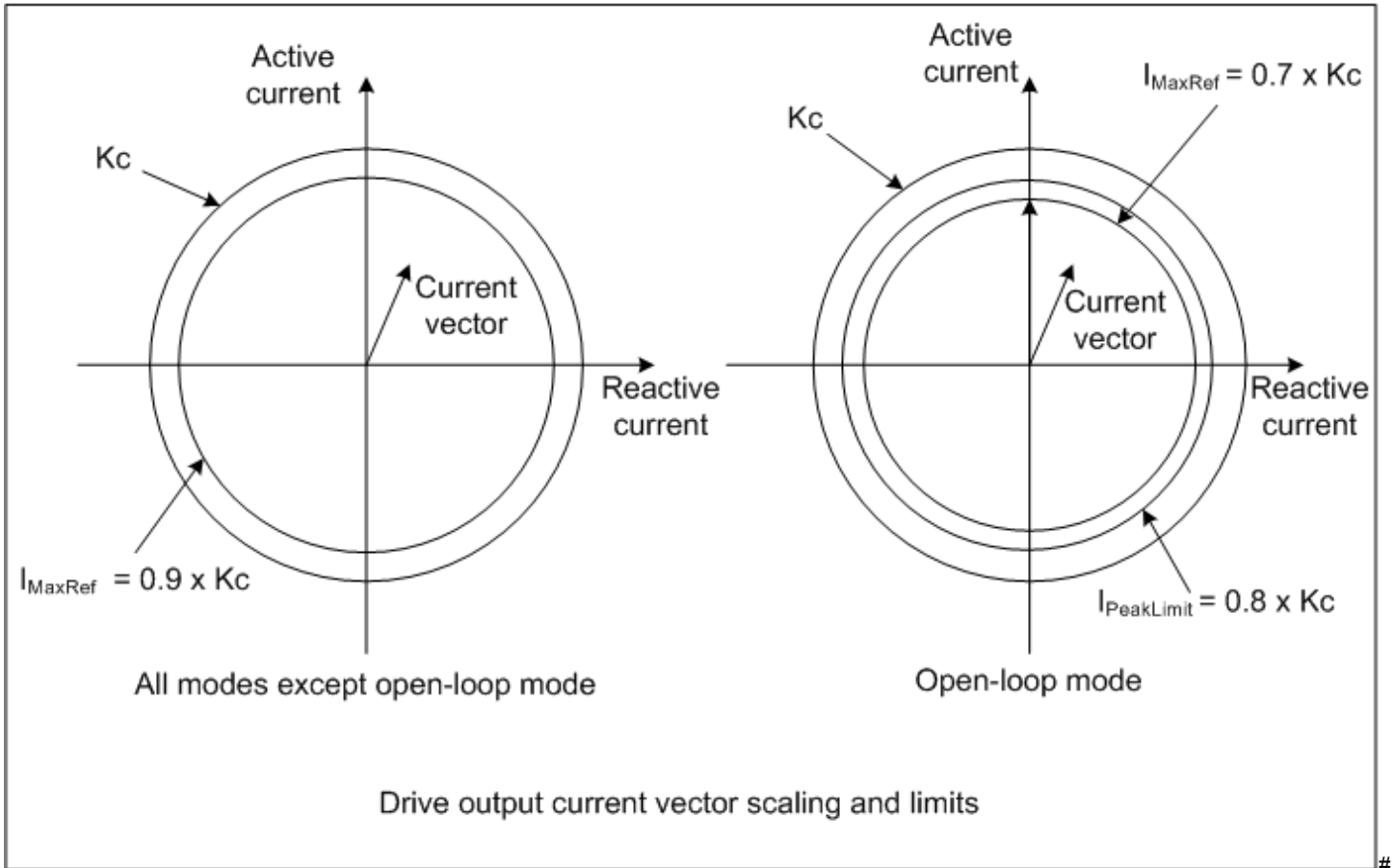

Throughout this section *Rated Current* (05.007) and other parameters related to motor 1 are used. It should be noted that this applies if *Select Motor 2 Parameters* (11.045) = 0. If *Select Motor 2 Parameters* (11.045) = 1 then *M2 Rated Current* (21.007) and other parameter associated with motor 2 should be used instead.

The full scale current is the maximum current that the drive can measure and if the current exceeds this level the drive produces an over current trip. Kc is the current scaling for the drive and is used in determining the control performance of the drive. This is given in *Full Scale Current Kc* (11.061) and Kc is equal the full scale current in r.m.s. Amps. (Note that this is a change from Unidrive SP which used the full scale current multiplied by 0.45 for Kc.)

The maximum current reference is the highest magnitude of the current reference vector in the drive under any circumstances. The area between the maximum current reference and the full scale current provides headroom to allow for overshoot in the current controllers without tripping the drive. In all modes except Open-loop mode, the current limits can be adjusted so that the maximum current reference vector (I_{MaxRef}) is equal to $0.9 \times Kc$ provided *Rated Current* (05.007) is set to the *Maximum Heavy Duty Rating* (11.032) or less. If *Rated Current* (05.007) is set to a higher level then the current limits can be adjusted so that the maximum current reference vector (I_{MaxRef}) is equal to $1.1 \times \text{Maximum Rated Current}$ (11.060) or $0.9 \times Kc$ whichever is lower.

In Open-loop mode the current is limited by the peak limit system to a maximum level of $0.8 \times Kc$. The peak limit controls the total current, however the Open-loop control system current limit only applies to the torque producing current and would limit the maximum current to I_{MaxRef} if the magnetising current remains constant at its rated level. I_{MaxRef} must give headroom below the peak limit and is set at $0.7 \times Kc$, provided *Rated Current* (05.007) is set to the *Maximum Heavy Duty Rating* (11.032) or less. If *Rated Current* (05.007) is set to a higher level then the current limits can be adjusted so that the maximum current reference vector (I_{MaxRef}) is equal to $1.1 \times \text{Maximum Rated Current}$ (11.060) or $0.7 \times Kc$ whichever is lower.

The drive can have a heavy duty rating intended for applications where high overload current may be required under transient conditions, or it can have a normal duty rating where a lower level of overload current is required. The duty rating is selected automatically by the drive based on the setting of *Rated Current* (05.007). The *Maximum Heavy Duty Rating* (11.032) and *Maximum Rated Current* (11.060) are fixed for each drive size and the table below shows the possible duty ratings that can be selected depending on the levels of these parameters.

Conditions	Possible duty ratings
<i>Maximum Heavy Duty Rating</i> (11.032) = 0.00	Normal duty operation only
<i>Maximum Heavy Duty Rating</i> (11.032) < <i>Maximum Rated Current</i> (11.060)	Heavy duty operation if rated current > MAX, otherwise normal duty operation
<i>Maximum Heavy Duty Rating</i> (11.032) = <i>Maximum Rated Current</i> (11.060)	Heavy duty operation only

The different duty ratings modify the motor protection characteristic (see *Motor Thermal Time Constant 1* (04.015) for motor control modes, and *Inductor Thermal Time Constant* (04.015) for Regen mode). The different duty ratings can also change the level of I_{MaxRef} as described previously.

In a drive that contains multiple power modules *Full Scale Current Kc* (11.061) is the full scale current of an individual module multiplied by the number of modules. *Maximum Heavy Duty Rating* (11.032) and *Maximum Rated Current* (11.060) are the value for an individual module multiplied by the number of modules.

Variable Maximums applied to the current limits

The variable maximums applied to the current limit parameters are VM_MOTOR1_CURRENT_LIMIT for motor map 1 and VM_MOTOR2_CURRENT_LIMIT for motor map 2. The calculations given below are used in each drive mode to define VM_MOTOR1_CURRENT_LIMIT. Similar calculations based on the equivalent motor map 2 parameters are used to define

VM_MOTOR2_CURRENT_LIMIT.

Regen mode

In Regen mode the drive orientates the output current vector to align with the voltage vector that represents the voltage at its terminals, and so unless specifically required, all the current is active current and there is no reactive current. Therefore the maximum value for the current limit parameters is calculated in the same way as for RFC-S mode:

$$VM_MOTOR1_CURRENT_LIMIT = (I_{MaxRef} / I_{Rated}) \times 100\%$$

where

$$I_{Rated} = \text{Rated Current (05.007)}$$

A maximum is applied to the reactive current reference parameter so that the combined current reference for the active and reactive currents does not exceed I_{MaxRef} .

$$VM_REGEN_REACTIVE = \sqrt{(VM_MOTOR1_CURRENT_LIMIT^2 - I_{Limit}^2)}$$

where

I_{Limit} gives the highest level of the active current reference that can occur. This value is defined by the current limit values. If the current limits are all set to their maximum values (i.e. VM_MOTOR1_CURRENT_LIMIT) then there is no current capability left for the reactive current. However, if the current limits are reduced the resulting headroom can be used for the reactive current. I_{Limit} is defined by a combination of all the current limits excluding any reduction of the current limit due to the motor thermal model. It should be noted that if *Island Detection Enable* (03.030) = 1 then VM_REGEN_REACTIVE is reduced by 5% to allow for the islanding system injection current.

Parameter	04.001 Current Magnitude		
Short description	Shows the instantaneous drive output current		
Mode	Regeneration		
Minimum	-VM_DRIVE_CURRENT_UNIPOLAR	Maximum	VM_DRIVE_CURRENT_UNIPOLAR
Default		Units	A
Type	32 Bit Volatile	Update Rate	4ms write
Display Format	Standard	Decimal Places	3
Coding	RO, FI, VM, ND, NC, PT		

Current Magnitude (04.001) is the instantaneous regen drive output current scaled so that it represents the r.m.s. phase current in Amps under steady state conditions.

Parameter	04.002 Active Current		
Short description	Shows the instantaneous level of active current		
Mode	Regeneration		
Minimum	-VM_DRIVE_CURRENT	Maximum	VM_DRIVE_CURRENT
Default		Units	A
Type	32 Bit Volatile	Update Rate	250µs write
Display Format	Standard	Decimal Places	3
Coding	RO, FI, VM, ND, NC, PT		

Active Current (04.002) is the instantaneous level of active current scaled so that it represents the r.m.s. level of active current under steady state conditions. The *Active Current* (04.002) is positive when power is flow from the supply and negative when power is flowing into the supply.

Parameter	04.004 Final Active Current Reference		
Short description	Shows the final current reference after the current limits		
Mode	Regeneration		
Minimum	-VM_TORQUE_CURRENT	Maximum	VM_TORQUE_CURRENT
Default		Units	%
Type	16 Bit Volatile	Update Rate	250µs read
Display Format	Standard	Decimal Places	1
Coding	RO, FI, VM, ND, NC, PT		

The *Final Active Current Reference* (04.004) is the active current reference from the d.c. bus voltage controller and power feed-forward system or user defined value with the current limits applied.

Parameter	04.005 Power From Supply Current Limit		
Short description	Defines the current limit used when power is being taken from the supply		
Mode	Regeneration		
Minimum	-VM_MOTOR1_CURRENT_LIMIT	Maximum	VM_MOTOR1_CURRENT_LIMIT
Default	0.0	Units	%
Type	16 Bit User Save	Update Rate	4ms read
Display Format	Standard	Decimal Places	1
Coding	RW, VM, RA		

The *Power From Supply Current Limit* (04.005) limits the active current when power is being taken from the supply. The *Power To Supply Current Limit* (04.006) limits the active current when power is being fed back into the supply. If the *Symmetrical Current Limit* (04.007) is below the

Power From Supply Current Limit (04.005) then it is used instead of the *Power From Supply Current Limit* (04.005). If the *Symmetrical Current Limit* (04.007) is below the *Power To Supply Current Limit* (04.006) then it is used instead of the *Power To Supply Current Limit* (04.006). It should be noted that if the current limits become active it is no longer possible for the d.c. bus voltage to be controlled.

The maximum possible current limit (VM_MOTOR1_CURRENT_LIMIT [MAX]) varies between drive sizes with default parameters loaded. For some drive sizes the default value may be reduced below the value given by the parameter range limiting.

Parameter	04.006 Power To Supply Current Limit		
Short description	Defines the current limit used when power is being fed back into the supply		
Mode	Regeneration		
Minimum	-VM_MOTOR1_CURRENT_LIMIT	Maximum	VM_MOTOR1_CURRENT_LIMIT
Default	0.0	Units	%
Type	16 Bit User Save	Update Rate	4ms read
Display Format	Standard	Decimal Places	1
Coding	RW, VM, RA		

See *Power From Supply Current Limit* (04.005).

Parameter	04.007 Symmetrical Current Limit		
Short description	Defines the symmetrical current limit		
Mode	Regeneration		
Minimum	-VM_MOTOR1_CURRENT_LIMIT	Maximum	VM_MOTOR1_CURRENT_LIMIT
Default	0.0	Units	%
Type	16 Bit User Save	Update Rate	4ms read
Display Format	Standard	Decimal Places	1
Coding	RW, VM, RA		

See *Power From Supply Current Limit* (04.005).

Parameter	04.008 Reactive Current Reference		
Short description	Defines the reactive current reference		
Mode	Regeneration		
Minimum	-VM_REGEN_REACTIVE	Maximum	VM_REGEN_REACTIVE
Default	0.0	Units	%
Type	16 Bit User Save	Update Rate	250µs read
Display Format	Standard	Decimal Places	1
Coding	RW, VM		

Reactive Current Reference (04.008) can be used to define a level of reactive current other than the default value of zero, so that the regen drive can be made to produce or consume reactive power. *Reactive Current Reference* (04.008) defines the level of reactive current as a percentage of the *Rated Current* (05.007). Positive reactive current produces a component of current flowing from the supply to the regen that lags the respective phase voltage, and negative reactive current produces a component of current that leads the respective voltage.

The variable maximum applied to *Reactive Current Reference* (04.008) is used to ensure that the total current does not exceed the maximum allowed. If the current limits are at their maximum values then no reactive current is allowed and VM_REGEN_REACTIVE_REFERENCE[MIN] = 0 and VM_REGEN_REACTIVE_REFERENCE[MAX] = 0. As the *Final Current Limit* (04.018) is reduced then more reactive current is allowed.

Parameter	04.009 Active Current Reference		
Short description	Defines the active current reference		
Mode	Regeneration		
Minimum	-VM_USER_CURRENT	Maximum	VM_USER_CURRENT
Default	0.0	Units	%
Type	16 Bit User Save	Update Rate	250µs read
Display Format	Standard	Decimal Places	1
Coding	RW, VM		

If *Active Current Reference Selector* (04.010) = 0 then the active current reference is defined by the d.c. bus voltage controller and the power feed-forward system. If *Active Current Reference Selector* (04.010) = 1 then the user can define the active current reference. The polarity of *Active Current Reference* (04.009) is the same as *Active Current* (04.002), and so a positive value causes power to flow from the supply to the regen drive, and a negative values causes power to flow from the regen drive to the supply. The following should be noted:

1. When the regen drive first becomes active the d.c. bus voltage controller will be active and will raise the d.c. voltage to the reference level defined by *Voltage Set Point* (03.005). Once the required level is reached the d.c. voltage controller is disabled and the active current reference can be controlled with *Active Current Reference* (04.009).
2. If the d.c. bus controller is not active then either the d.c. bus voltage must be defined by another system connected to the d.c. bus or some form of control must be provided by the user.

Parameter	04.010 Active Current Reference Selector		
Short description	Set to enable the user active current reference		
Mode	Regeneration		
Minimum	0	Maximum	1
Default	0	Units	
Type	1 Bit User Save	Update Rate	4ms read
Display Format	Standard	Decimal Places	0
Coding	RW		

See *Active Current Reference* (04.009).

Parameter	04.013 Current Controller Kp Gain		
Short description	Defines the current loop controller proportional gain		
Mode	Regeneration		
Minimum	0	Maximum	30000
Default	90	Units	
Type	16 Bit User Save	Update Rate	Background read
Display Format	Standard	Decimal Places	0
Coding	RW		

Current Controller Kp Gain (04.013) and *Current Controller Ki Gain* (04.014) are the proportional and integral gains of the current controllers. Either standard or high performance modes, selected with *Current Controller Mode* (04.030), can be used for a regen drive. In many applications the default gains can be used, but under certain supply conditions it is necessary to reduce the *Current Controller Kp Gain* (04.013) to prevent instability.

Parameter	04.014 Current Controller Ki Gain		
Short description	Defines the current loop controller integral gain		
Mode	Regeneration		
Minimum	0	Maximum	30000
Default	2000	Units	
Type	16 Bit User Save	Update Rate	Background read
Display Format	Standard	Decimal Places	0
Coding	RW		

See *Current Controller Kp Gain* (04.013).

Parameter	04.015 Inductor Thermal Time Constant		
Short description	Set to the inductor thermal time constant		
Mode	Regeneration		
Minimum	1.0	Maximum	3000.0
Default	89.0	Units	s
Type	16 Bit User Save	Update Rate	Background read
Display Format	Standard	Decimal Places	1
Coding	RW		

A single time constant thermal model is provided that can be used to estimate the temperature of the regen inductors connected between the regen drive and the supply. The input to the model is the *Current Magnitude* (04.001). The *Inductor Protection Accumulator* (04.019) is given by the following equation.

$$T = 100.0\% \times [I / (K_1 \times I_{\text{Rated}})]^2 \times (1 - e^{-t/\tau})$$

where:

T = *Inductor Protection Accumulator* (04.019)

I = *Current Magnitude* (04.001)

I_{Rated} = *Rated Current* (05.007)

τ = *Inductor Thermal Time Constant* (04.015)

If *Rated Current* (05.007) ≤ *Maximum Heavy Duty Rating* (11.032) then K₁ = 1.05, otherwise K₁ = 1.01.

Inductor Protection Accumulator Reset

The initial value in the *Inductor Protection Accumulator* (04.019) at power-up is defined by *Inductor Protection Accumulator Power-up Value* (04.036) as given in the table below.

Inductor Protection Accumulator Power-up Value (04.036)	Inductor Protection Accumulator (04.019) at power-up
Power Down	The value is saved at power-down and is used as the initial value at power-up.
Zero	The value is set to zero.
Real Time	<p>If a real-time clock is present and if <i>Date/Time Selector</i> (06.019) is set up to select the real-time clock then the value saved at power-down is modified to include the effect of the inductor thermal protection time constants over the time between power-down and power-up. This modified value is then used as the initial value at power-up.</p> <p>If no real time clock is present then and this option is selected then the value saved at power-down is used as the initial value.</p>

The *Inductor Protection Accumulator* (04.019) is reset under the following conditions:

1. *Inductor Thermal Time Constant* (04.015) is set to 0.0. Note that this is not possible in the standard product as the minimum parameter value is 1.0.
2. *Rated Current* (05.007) is modified.

Inductor Protection Accumulator Warning

If $[I / (K_1 \times I_{Rated})]^2 > 1.0$ then eventually the *Inductor Protection Accumulator* (04.019) will reach 100% causing the regen drive to trip. If this is the case and *Inductor Protection Accumulator* (04.019) > 75.0% then [Ind Overload] alarm indication is given and *Inductor Overload Alarm* (10.017) is set to one.

Parameter	04.017 Reactive Current		
Short description	Shows the instantaneous level of reactive current		
Mode	Regeneration		
Minimum	-VM_DRIVE_CURRENT	Maximum	VM_DRIVE_CURRENT
Default		Units	A
Type	32 Bit Volatile	Update Rate	250µs write
Display Format	Standard	Decimal Places	3
Coding	RO, FI, VM, ND, NC, PT		

Reactive Current (04.017) is the instantaneous level of reactive current scaled so that it represents the r.m.s. level of reactive current under steady state conditions.

Parameter	04.018 Final Current Limit		
Short description	Shows the final current limit that is applied to the active current		
Mode	Regeneration		
Minimum	-VM_TORQUE_CURRENT	Maximum	VM_TORQUE_CURRENT
Default		Units	%
Type	16 Bit Volatile	Update Rate	4ms write
Display Format	Standard	Decimal Places	1
Coding	RO, VM, ND, NC, PT		

Final Current Limit (04.018) is the current limit level that is applied to the active current.

Parameter	04.019 Inductor Protection Accumulator		
Short description	Shows the level of the inductor protection accumulator		
Mode	Regeneration		
Minimum	0.0	Maximum	100.0
Default		Units	%
Type	16 Bit Power Down Save	Update Rate	Background write
Display Format	Standard	Decimal Places	1
Coding	RO, ND, NC, PT		

See *Inductor Thermal Time Constant* (04.015).

Parameter	04.020 Percentage Load		
Short description	Shows the level of active current as a percentage of rated current		
Mode	Regeneration		
Minimum	-VM_USER_CURRENT	Maximum	VM_USER_CURRENT
Default		Units	%
Type	16 Bit Volatile	Update Rate	Background write
Display Format	Standard	Decimal Places	1
Coding	RO, FI, VM, ND, NC, PT		

Percentage Load (04.020) gives the *Active Current* (04.002) as a percentage of the *Rated Current* (05.007). Positive values indicate power flow from the supply to the regen drive and negative values indicate power flow from the regen drive to the supply.

Parameter	04.021 Current Feedback Filter Disable		
Short description	Disables the 16ms filter applied to current feedback parameters		
Mode	Regeneration		
Minimum	0	Maximum	1
Default	0	Units	
Type	1 Bit User Save	Update Rate	Background read
Display Format	Standard	Decimal Places	0
Coding	RW		

If *Current Feedback Filter Disable* (04.021) = 0 a 4ms filter is applied to the current feedback components measured by the drive to be used in *Active Current* (04.002) and *Reactive Current* (04.017). This filter removes ripple components associated with the PWM switching. If *Current Feedback Filter Disable* (04.021) = 1, the filter is disabled and the user parameters are based on the current components sampled every 250us.

Parameter	04.024 User Current Maximum Scaling		
Short description	Defines the maximum for the active current reference and percentage load parameters		
Mode	Regeneration		
Minimum	-VM_TORQUE_CURRENT_UNIPOLAR	Maximum	VM_TORQUE_CURRENT_UNIPOLAR
Default	175.0	Units	%
Type	16 Bit User Save	Update Rate	Background read
Display Format	Standard	Decimal Places	1
Coding	RW, VM, RA		

User Current Maximum Scaling (04.024) defines the variable maximum/minimum VM_USER_CURRENT which is applied to *Percentage Load* (04.020) and *Active Current Reference* (04.009). This is useful when routing these parameters to an analog output as it allows the full scale output value to be defined by the user.

The maximum value (VM_TORQUE_CURRENT_UNIPOLAR [MAX]) varies between drive sizes with default parameters loaded. For some drive sizes the default value may be reduced below the value given by the parameter range limiting.

Parameter	04.036 Inductor Protection Accumulator Power-up Value		
Short description	Defines the initial power-up value of the inductor protection accumulator		
Mode	Regeneration		
Minimum	0	Maximum	2
Default	0	Units	
Type	8 Bit User Save	Update Rate	Background write
Display Format	Standard	Decimal Places	0
Coding	RW, TE		

Value	Text
0	Power down
1	Zero
2	Real time

See *Inductor Thermal Time Constant* (04.015).

Parameter	04.040 Final Reactive Current Reference		
Short description	Shows the final reactive current reference		
Mode	Regeneration		
Minimum	-200.0	Maximum	200.0
Default		Units	%
Type	16 Bit Volatile	Update Rate	250µs write
Display Format	Standard	Decimal Places	1
Coding	RO, FI, ND, NC, PT		

Final Reactive Current Reference (04.040) gives the reactive current reference that is defined by the user plus any current that is injected by the island detection system.

Menu 5 Single Line Descriptions – Regen Status

Mode: Regeneration

Parameter		Range	Default	Type					
05.001	Output Frequency	±200.0 Hz		RO	Num	ND	NC	PT	FI
05.002	Output Voltage	±VM_AC_VOLTAGE V		RO	Num	ND	NC	PT	FI
05.003	Output Power	±VM_POWER kW		RO	Num	ND	NC	PT	FI
05.005	D.c. Bus Voltage	±VM_DC_VOLTAGE V		RO	Num	ND	NC	PT	FI
05.007	Rated Current	±VM_RATED_CURRENT A	0.000 A	RW	Num		RA		US
05.018	Maximum Switching Frequency	0 to VM_SWITCHING_FREQUENCY kHz	3 (1) kHz	RW	Txt		RA		US
05.035	Auto-switching Frequency Change	Enabled (0), Disabled (1), No Ripple Detect (2)	Enabled (0)	RW	Txt				US
05.036	Auto-switching Frequency Step Size	1 to 2	2	RW	Num				US
05.037	Switching Frequency	2 (0), 3 (1), 4 (2), 6 (3), 8 (4), 12 (5), 16 (6) kHz		RO	Txt	ND	NC	PT	
05.038	Minimum Switching Frequency	0 to VM_MIN_SWITCHING_FREQUENCY kHz	3 (1) kHz	RW	Txt				US
05.039	Maximum Inverter Temperature Ripple	20 to 60 °C	60 °C	RW	Num				US

RW	Read / Write	RO	Read-only	Bit	Bit parameter	Txt	Text string	Date	Date parameter	Time	Time parameter
Chr	Character parameter	Bin	Binary parameter	IP	IP address	Mac	MAC address	Ver	Version number	SMP	Slot, menu, parameter
Num	Number parameter	DE	Destination	ND	No default value	RA	Rating dependent	NC	Non-copyable	PT	Protected
FI	Filtered	US	User save	PS	Power-down save						

Menu 5 – Regen Status

Mode: Regeneration

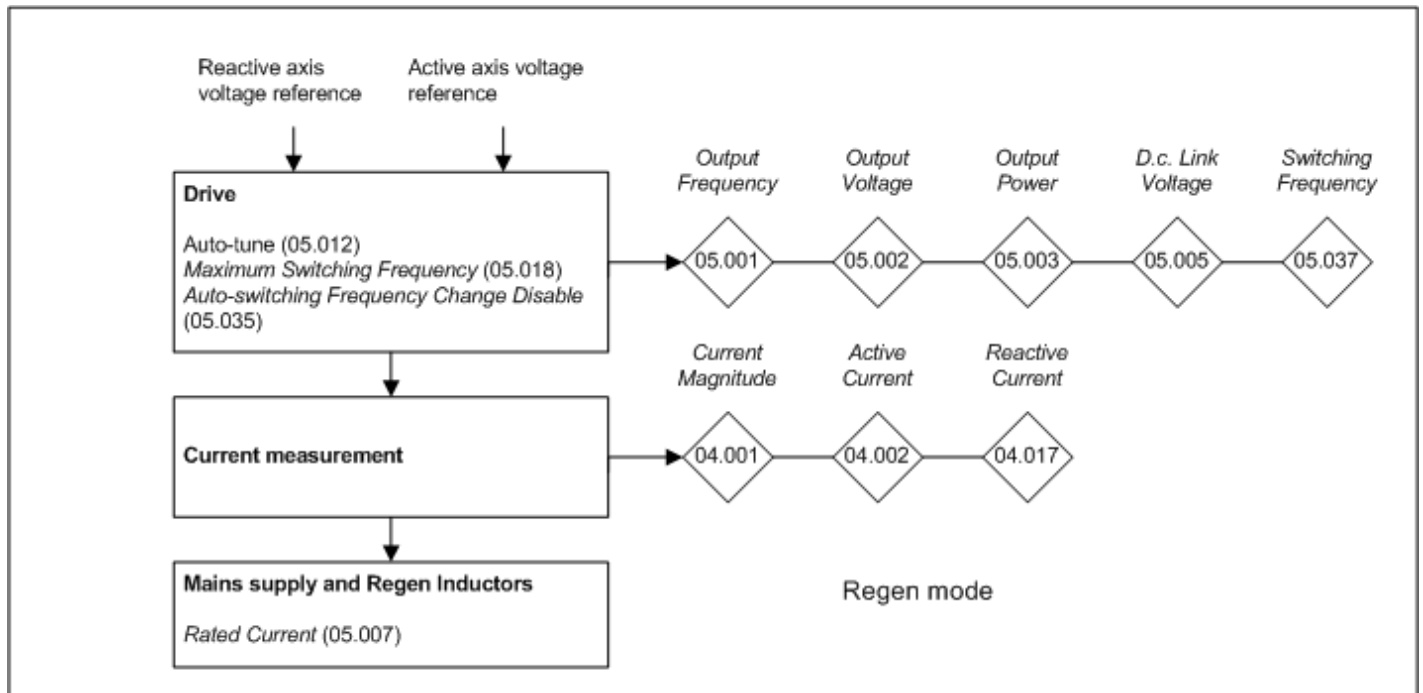

Parameter	05.001 Output Frequency		
Short description	Displays the value of the supply frequency		
Mode	Regeneration		
Minimum	-200.0	Maximum	200.0
Default		Units	Hz
Type	32 Bit Volatile	Update Rate	4ms write
Display Format	Standard	Decimal Places	1
Coding	RO, FI, ND, NC, PT		

The *Output Frequency* (05.001) is a measure of the supply frequency. If the frequency shown is positive it indicates that the supply phase sequence is U-V-W. If it is negative it indicates that the supply phase sequence is W-V-U.

Parameter	05.002 Output Voltage		
Short description	Displays the r.m.s. line to line voltage at the a.c. terminals of the drive		
Mode	Regeneration		
Minimum	-VM_AC_VOLTAGE	Maximum	VM_AC_VOLTAGE
Default		Units	V
Type	16 Bit Volatile	Update Rate	4ms write
Display Format	Standard	Decimal Places	0
Coding	RO, FI, VM, ND, NC, PT		

The *Output Voltage* (05.002) is the r.m.s. line to line voltage at the a.c. terminals of the drive.

Parameter	05.003 Output Power		
Short description	Displays the power flowing via the a.c. terminals of the drive		
Mode	Regeneration		
Minimum	-VM_POWER	Maximum	VM_POWER
Default		Units	kW
Type	32 Bit Volatile	Update Rate	4ms write
Display Format	Standard	Decimal Places	3
Coding	RO, FI, VM, ND, NC, PT		

The *Output Power* (05.003) is the power flowing via the a.c. terminals of the drive. The power is derived as the dot product of the output voltage and current vectors, and so this is correct even if the motor parameters are incorrect and the motor model does not align the reference frame with the flux axis of a motor in RFC-A mode. For Open-loop, RFC-A and RFC-S modes a positive value of power indicates power flowing from the drive to motor. For Regen mode a positive value of power indicates power flowing from the supply to the regen drive.

Parameter	05.005 D.c. Bus Voltage		
Short description	Displays the voltage across the d.c. link of the drive		
Mode	Regeneration		
Minimum	-VM_DC_VOLTAGE	Maximum	VM_DC_VOLTAGE
Default		Units	V
Type	16 Bit Volatile	Update Rate	Background read
Display Format	Standard	Decimal Places	0
Coding	RO, FI, VM, ND, NC, PT		

D.c. Bus Voltage (05.005) gives the voltage across the d.c. link of the drive.

Parameter	05.007 Rated Current		
Short description	Set to the rated current rated of the regen inductor		
Mode	Regeneration		
Minimum	-VM_RATED_CURRENT	Maximum	VM_RATED_CURRENT
Default	0.000	Units	A
Type	32 Bit User Save	Update Rate	Background read
Display Format	Standard	Decimal Places	3
Coding	RW, VM, RA		

Rated Current (05.007) is used to define rated operating conditions for regen inductor thermal protection. See *Inductor Thermal Time Constant* (04.015).

Parameter	05.018 Maximum Switching Frequency		
Short description	Defines the maximum switching frequency that can be used by the drive		
Mode	Regeneration		
Minimum	0	Maximum	VM_SWITCHING_FREQUENCY
Default	1	Units	kHz
Type	8 Bit User Save	Update Rate	Background read
Display Format	Standard	Decimal Places	0
Coding	RW, TE, VM, RA		

Value	Text
0	2
1	3
2	4
3	6
4	8
5	12
6	16

Maximum Switching Frequency (05.018) should be set to the required PWM switching frequency. The drive inverter will operate at this frequency unless the inverter temperature becomes too hot. Under these conditions the drive will reduce the switching frequency in an attempt to avoid tripping (see *Auto-switching Frequency Change* (05.035)). The actual switching frequency is shown in *Switching Frequency* (05.037). The switching frequency has a direct effect on the sample rate for the current controllers (see *Current Controller Kp Gain* (04.013)). All other control tasks are at a fixed rate.

Task	
Speed controller (RFC-A, RFC-S)	250µs
D.c. link voltage controller	1ms
Flux controller (RFC-A, RFC-S)	1ms

Parameter	05.035 Auto-switching Frequency Change		
Short description	Defines auto-switching frequency control with thermal model		
Mode	Regeneration		
Minimum	0	Maximum	2
Default	0	Units	
Type	8 Bit User Save	Update Rate	Background read
Display Format	Standard	Decimal Places	0
Coding	RW, TE		

Value	Text
0	Enabled
1	Disabled
2	No Ripple Detect

The drive inverter can be damaged if the temperature is too high. The inverter can also be damaged or the lifetime of the power devices reduced, if the temperature ripple of the devices is too high. *Auto-switching Frequency Change* (05.035) defines the action taken if the drive inverter becomes too hot or the temperature ripple becomes too high.

Enabled:

If the inverter becomes too hot or the ripple temperature is higher than the level defined by *Maximum Inverter Temperature Ripple* (05.039) the switching frequency is reduced in an attempt to prevent tripping.

Disabled:

The switching frequency is not reduced, and so the drive will trip if the inverter is too hot or the temperature ripple is too high.

No Ripple Detect:

The switching frequency is reduced if the inverter temperature, but not the temperature ripple is too high. If the temperature ripple exceeds the level defined by *Maximum Inverter Temperature Ripple* (05.039) then the drive will trip.

The switching frequency is changed in steps defined by *Auto-switching Frequency Step Size* (05.036). For example with a switching frequency of 16kHz and a step size of two, the frequency will be reduced to 8kHz, then 4kHz etc. *Minimum Switching Frequency* (05.038) defines the minimum switching frequency that the system will attempt to use. If the switching frequency needs to switch to a lower level, then the drive will trip.

If *Minimum Switching Frequency* is changed the new value will only become active when *Switching Frequency* is at or above the minimum value.

Parameter				05.036 Auto-switching Frequency Step Size			
Short description				Auto-switching frequency reduction step size			
Mode				Regeneration			
Minimum		1		Maximum		2	
Default		2		Units			
Type		8 Bit User Save		Update Rate		Background read	
Display Format		Standard		Decimal Places		0	
Coding				RW			

See *Auto-switching Frequency Change* (05.035).

Parameter				05.037 Switching Frequency			
Short description				Displays the current switching frequency used by the drive			
Mode				Regeneration			
Minimum		0		Maximum		6	
Default				Units		kHz	
Type		8 Bit Volatile		Update Rate		Background write	
Display Format		Standard		Decimal Places		0	
Coding				RO, TE, ND, NC, PT			

Value	Text
0	2
1	3
2	4
3	6
4	8
5	12
6	16

Shows the actual inverter switching frequency after the auto-change function.

Parameter				05.038 Minimum Switching Frequency			
Short description				Minimum Switching Frequency			
Mode				Regeneration			
Minimum		0		Maximum		VM_MIN_SWITCHING_FREQUENCY	
Default		1		Units		kHz	
Type		8 Bit User Save		Update Rate		Background Read	
Display Format		Standard		Decimal Places		0	
Coding				RW, TE, VM			

Value	Text
0	2
1	3
2	4
3	6
4	8
5	12
6	16

See *Auto-switching Frequency Change* (05.035).

Parameter	05.039 <i>Maximum Inverter Temperature Ripple</i>		
Short description	Maximum Inverter Temperature Ripple		
Mode	Regeneration		
Minimum	20	Maximum	60
Default	60	Units	°C
Type	8 Bit User Save	Update Rate	Background Read
Display Format	Standard	Decimal Places	0
Coding	RW		

Maximum Inverter Temperature Ripple (05.039) defines the maximum inverter temperature ripple allowed before the switching frequency is reduced. See *Auto-switching Frequency Change* (05.035).

Menu 6 Single Line Descriptions – Sequencer and Clock

Mode: Regeneration

Parameter		Range	Default	Type					
06.010	Enable Conditions	000000000000 to 111111111111		RO	Bin	ND	NC	PT	
06.011	Sequencer State Machine Inputs	000000 to 111111		RO	Bin	ND	NC	PT	
06.015	Drive Enable	Off (0) or On (1)	On (1)	RW	Bit				US
06.016	Date	00-00-00 to 31-12-99		RW	Date	ND	NC	PT	
06.017	Time	00:00:00 to 23:59:59		RW	Time	ND	NC	PT	
06.018	Day Of Week	Sunday (0), Monday (1), Tuesday (2), Wednesday (3), Thursday (4), Friday (5), Saturday (6)		RO	Txt	ND	NC	PT	
06.019	Date/Time Selector	Set (0), Powered (1), Running (2), Acc Powered (3), Local Keypad (4), Remote Keypad (5)	Powered (1)	RW	Txt				US
06.020	Date Format	Std (0), US (1)	Std (0)	RW	Txt				US
06.021	Time Between Filter Changes	0 to 30000 Hours	0 Hours	RW	Num				US
06.022	Filter Change Required / Change Done	Off (0) or On (1)		RW	Bit	ND	NC		
06.023	Time Before Filter Change Due	0 to 30000 Hours		RO	Num	ND	NC	PT	PS
06.024	Reset Energy Meter	Off (0) or On (1)	Off (0)	RW	Bit				
06.025	Energy Meter: MWh	±999.9 MWh		RO	Num	ND	NC	PT	PS
06.026	Energy Meter: kWh	±99.99 kWh		RO	Num	ND	NC	PT	PS
06.027	Energy Cost Per kWh	0.0 to 600.0	0.0	RW	Num				US
06.028	Running Cost	±32000		RO	Num	ND	NC	PT	
06.029	Hardware Enable	Off (0) or On (1)		RO	Bit	ND	NC	PT	
06.041	Drive Event Flags	00 to 11	00	RW	Bin		NC		
06.042	Control Word	0000000000000000 to 1111111111111111	0000000000000000	RW	Bin		NC		
06.043	Control Word Enable	Off (0) or On (1)	Off (0)	RW	Bit				US
06.044	Active Supply	Off (0) or On (1)		RO	Bit	ND	NC	PT	
06.045	Cooling Fan control	-10 to 11	-10	RW	Num				US
06.046	Cooling Fan Speed	0 to 10		RO	Num	ND	NC	PT	
06.060	Standby Mode Enable	Off (0) or On (1)	Off (0)	RW	Bit				US
06.061	Standby Mode Mask	0000000 to 1111111	0000000	RW	Bin				US
06.065	Standard Under Voltage Threshold	0 to VM_STD_UNDER_VOLTS V	200V drive: 175 V 400V drive: 330 V 575V drive: 435 V 690V drive: 435 V	RW	Num		RA		US
06.066	Low Under Voltage Threshold	0 to VM_LOW_UNDER_VOLTS V	330 V	RW	Num		RA		US
06.067	Low Under Voltage Threshold Select	Off (0) or On (1)	Off (0)	RW	Bit				US
06.073	Braking IGBT Lower Threshold	0 to VM_DC_VOLTAGE_SET V	200V drive: 390 V 400V drive: 780 V 575V drive: 930 V 690V drive: 1120 V	RW	Num		RA		US
06.074	Braking IGBT Upper Threshold	0 to VM_DC_VOLTAGE_SET V	200V drive: 390 V 400V drive: 780 V 575V drive: 930 V 690V drive: 1120 V	RW	Num		RA		US
06.075	Low Voltage Braking IGBT Threshold	0 to VM_DC_VOLTAGE_SET V	0 V	RW	Num		RA		US
06.076	Low Voltage Braking IGBT Threshold Select	Off (0) or On (1)	Off (0)	RW	Bit				
06.084	Date And Time Offset	±12.00 Hours	0.00 Hours	RW	Num				US

RW	Read / Write	RO	Read-only	Bit	Bit parameter	Txt	Text string	Date	Date parameter	Time	Time parameter
Chr	Character parameter	Bin	Binary parameter	IP	IP address	Mac	MAC address	Ver	Version number	SMP	Slot, menu, parameter
Num	Number parameter	DE	Destination	ND	No default value	RA	Rating dependent	NC	Non-copyable	PT	Protected
FI	Filtered	US	User save	PS	Power-down save						

Menu 6 – Sequencer and Clock

Mode: Regeneration

The diagram below shows the sequencer for Regen mode.

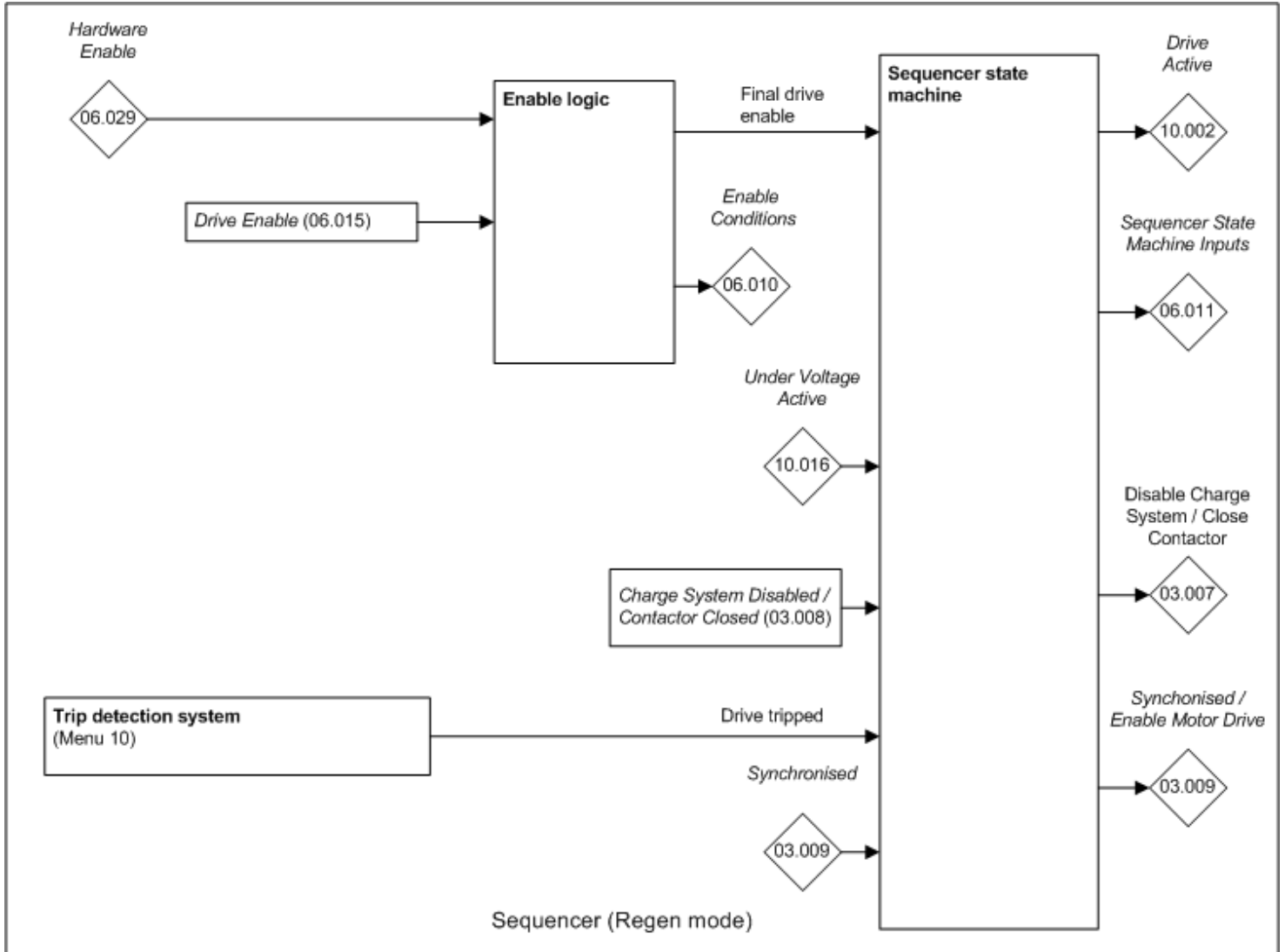

The sequencer, which provides overall control of the drive, is implemented in two stages. The first stage include the enable logic and consists of static logic elements. The second stage is a state machine with internal states.

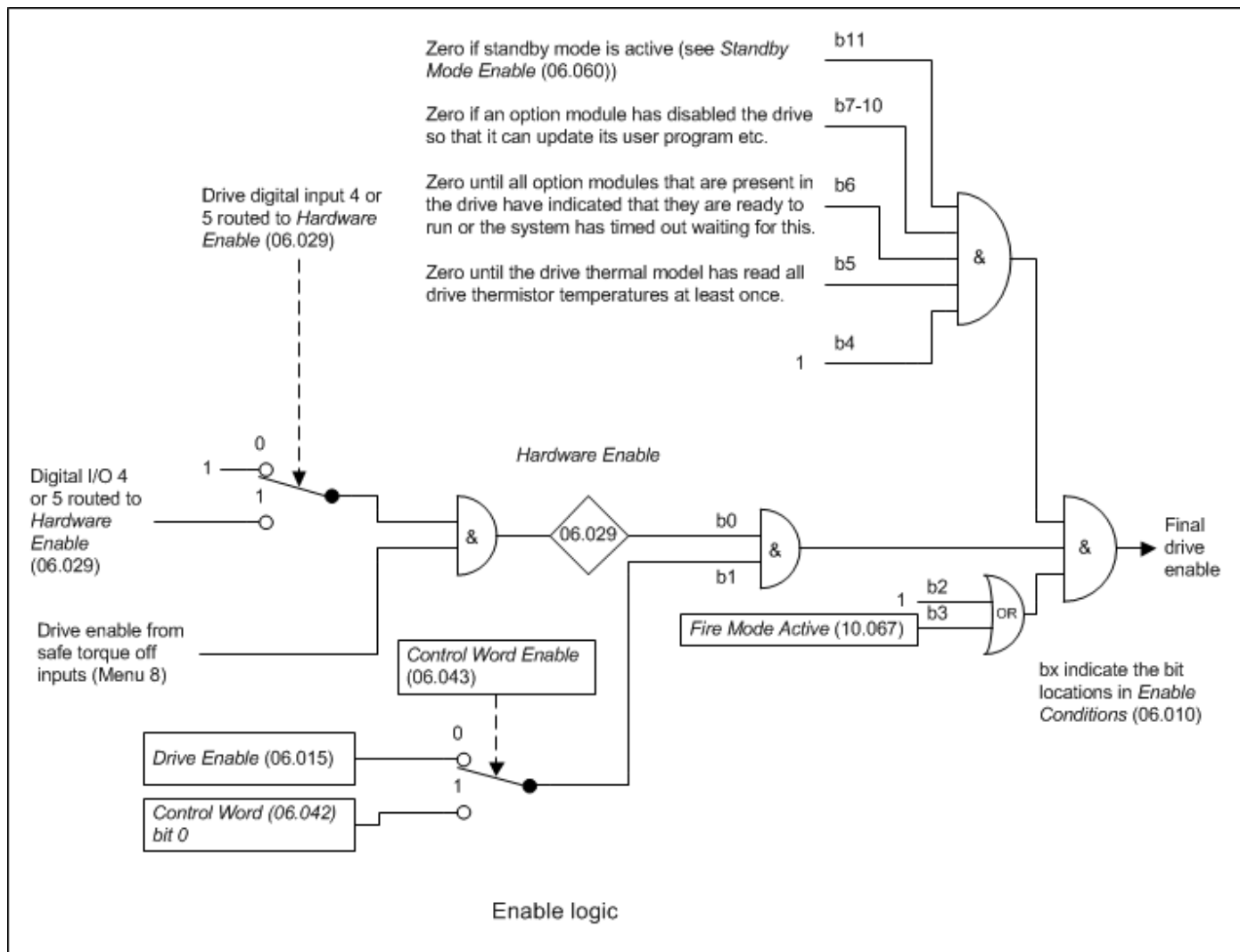

Hardware Enable (06.029) follows the safe torque off enable signal provided none of the digital inputs that are integral to the drive are routed to the *Hardware Enable* (06.029). The safe torque off hardware includes a delay in detecting a change from the enable to disable state of up to 20ms, but for most applications this is not a problem. However, a faster disable time can be achieved (600us) if digital input 4 or 5 on the drive is routed to the *Hardware Enable* (06.029).

If the safety function of the safe torque off input is required then there must not be a direct connection between the safe torque off input and any other digital I/O on the drive. If the safety function of the safe torque off input and a fast disable function are required together, then the drive should be given two separate independent enable input signals. A signal from a safe source should be connected to the safe torque off input on the drive. A second enable should be connected to the digital I/O selected for the fast disable function. The circuit must be arranged so that a fault which causes the fast input to be forced high cannot cause the safe torque off input to be forced high as well, including the case where a component such as a blocking diode has failed.

Parameter	06.010 <i>Enable Conditions</i>		
Short description	Displays all the conditions needed to change the state of the final drive enable		
Mode	Regeneration		
Minimum	0 (Display: 000000000000)	Maximum	4095 (Display: 111111111111)
Default	Units		
Type	16 Bit Volatile	Update Rate	2ms write
Display Format	Binary	Decimal Places	0
Coding	RO, ND, NC, PT		

The Final drive enable is a combination of the *Hardware Enable* (06.029), *Drive Enable* (06.015) and other conditions that can prevent the drive from being enabled. All of these conditions are shown as bits in *Enable Conditions* (06.010) as given in the table below.

Enable Conditions (06.010) bits	Enable condition
0	<i>Hardware Enable</i> (06.029)
1	<i>Drive Enable</i> (06.015)
2	0 if auto-tune completed or trip during auto-tune, or if the drive stops when supply loss stop is active, but the drive needs to be disabled and re-enabled. (Always 1 in Regen mode).
3	1 if fire mode is active.
4	Zero if <i>Position Feedback Initialized</i> (03.076) is present and all devices are not indicated as initialised, otherwise one.
5	Zero until the drive thermal model has obtained temperatures from all drive thermistors at least once.
6	Zero until all option modules that are present in the drive have indicated that they are ready to run or the system has timed out waiting for this.
7-10	Zero if an option module has forced the drive to be disabled if for example it is updating its user program. Bit 7 corresponds to slot 1, bit 8 to slot 2, etc.
11	Zero if the drive is in standby mode. See <i>Standby Mode Enable</i> (06.060)

Parameter	06.011 Sequencer State Machine Inputs		
Short description	Displays the states of inputs into the sequencer state machine		
Mode	Regeneration		
Minimum	0 (Display: 000000)	Maximum	63 (Display: 111111)
Default		Units	
Type	8 Bit Volatile	Update Rate	2ms write
Display Format	Binary	Decimal Places	0
Coding	RO, ND, NC, PT		

The bits in *Sequencer State Machine Inputs* (06.011) show the state of the inputs to the sequencer state machine as given in the table below.

Sequencer State Machine Inputs (06.011)	Signal	Indicates
0	Final drive enable	The drive inverter is allowed to be enabled.
1	Not used	Always zero.
2	<i>Under Voltage Active</i> (10.016)	The under voltage condition has been detected.
3	<i>Charge System Disabled / Contactor Closed</i> (03.008)	Indicates when the external charge system contactor is closed.
4	Drive tripped	The drive is tripped.
5	<i>Synchronised</i> (03.009)	Regen system is synchronised to the supply

The table below shows each of the state machine states along with its exit conditions and actions. The status column shows the value written to *Drive Status* (10.101) and the associated strings are given in the table below for each of the state machine states.

State	Exit Conditions	Actions	Status
UNDER_VOLTAGE	<p>IF Drive tripped = 1 THEN</p> <p>State = TRIP_WITH_UNDER_VOLTAGE</p> <p>ELSE IF <i>Under Voltage Active</i> (10.016) = 0 THEN</p> <p>State = CURRENT_TRIM1</p>	<p><i>Drive Active</i> (10.002) = 0</p> <p><i>Disable Charge System / Close Contactor</i> (03.007) = 0</p>	15 [Under Voltage]
CURRENT_TRIM1	<p>IF Drive tripped = 1 THEN</p> <p>IF</p> <p><i>Disable Charge System / Close Contactor</i> (03.007) = 1 THEN</p> <p>State = TRIP</p> <p>ELSE</p> <p>State = TRIP_WITH_UNDER_VOLTAGE</p> <p>END</p> <p>ELSE IF <i>Under Voltage Active</i> (10.016) = 1 THEN</p> <p>State = UNDER_VOLTAGE</p> <p>ELSE IF Current trim complete THEN</p> <p>State = DISABLE</p>	<p><i>Drive Active</i> (10.002) = 0</p> <p>Current trim sequence as follows:</p> <p><i>Disable Charge System / Close Contactor</i> (03.007) = 0</p> <p>500ms delay</p> <p>Current offset trim</p> <p><i>Disable Charge System / Close Contactor</i> (03.007) = 1</p> <p>500ms delay to Current trim complete indication</p>	0 [Inhibit]
DISABLE	<p>IF Drive tripped = 1 THEN</p> <p>State = TRIP</p> <p>ELSE IF <i>Under Voltage Active</i> (10.016) = 1 THEN</p> <p>State = UNDER_VOLTAGE</p> <p>ELSE IF</p> <p><i>Charge System Disabled / Contactor Closed</i> (03.008) = 1 AND</p> <p>Final drive enable = 1 THEN</p> <p>{</p> <p>IF <i>Current Trim Mode</i> (03.011) = 0 THEN</p> <p>State = SYNCHRONISING</p> <p>ELSE</p> <p>State = CURRENT_TRIM2</p> <p>}</p>	<p><i>Drive Active</i> (10.002) = 0</p>	0 [Inhibit]
CURRENT_TRIM2	<p>IF Drive tripped = 1 THEN</p> <p>IF</p> <p><i>Disable Charge System / Close Contactor</i> (03.007) = 1 THEN</p> <p>State = TRIP</p> <p>ELSE</p> <p>State = TRIP_WITH_UNDER_VOLTAGE</p> <p>END</p> <p>ELSE IF <i>Under Voltage Active</i> (10.016) = 1 THEN</p> <p>State = UNDER_VOLTAGE</p> <p>ELSE IF Current trim complete THEN State = SYNCHRONISING</p>	<p><i>Drive Active</i> (10.002) = 0</p> <p>Current trim sequence as follows:</p> <p><i>Disable Charge System / Close Contactor</i> (03.007) = 0</p> <p>500ms delay</p> <p>Current offset trim</p> <p><i>Disable Charge System / Close Contactor</i> (03.007) = 1</p> <p>500ms delay to Current trim complete indication</p>	0 [Inhibit]

SYNCHRONISING	<p>IF Drive tripped = 1 THEN State = TRIP</p> <p>ELSE IF <i>Under Voltage Active</i> (10.016) = 1 THEN</p> <p>State = UNDER_VOLTAGE</p> <p>ELSE IF <i>Charge System Disabled / Contactor Closed</i> (03.008) = 0 THEN</p> <p>State = DISABLE</p> <p>ELSE IF Final drive enable = 0 THEN</p> <p>State = DISABLE</p> <p>ELSE IF Synchronised THEN</p> <p>State = SYNCHRONISED</p>	<p><i>Drive Active</i> (10.002) = 1</p> <p><i>Disable Charge System / Close Contactor</i> (03.007) = 1</p> <p>IF (<i>Regen Synchronisation Mode</i> (03.004) = 1</p> <p>OR 2) AND This state active for 30s THEN</p> <p>Initiate (<i>Line Sync</i>)</p>	3 [Scan]
SYNCHRONISED	<p>IF Drive tripped = 1 THEN</p> <p>State = TRIP</p> <p>ELSE IF <i>Under Voltage Active</i> (10.016) = 1 THEN</p> <p>State = UNDER_VOLTAGE</p> <p>ELSE IF <i>Charge System Disabled / Contactor Closed</i> (03.008) = 0 THEN</p> <p>State = DISABLE</p> <p>ELSE IF Final drive enable = 0 THEN</p> <p>State = DISABLE</p> <p>ELSE IF <i>Synchronised</i> (03.009) = 0</p> <p>State = SYNCHRONISING</p> <p>ELSE IF Not synchronised THEN</p> <p>State = SYNCHRONISING</p>	<p><i>Drive Active</i> (10.002) = 1</p> <p><i>Disable Charge System / Close Contactor</i> (03.007) = 1</p> <p>IF <i>Regen Synchronisation Mode</i> (03.004) = 2</p> <p>AND Not Synchronised THEN</p> <p>Initiate (<i>Line Sync</i>)</p>	10 [Active]
AUTO_TUNE	<p>IF Drive tripped = 1 THEN</p> <p>State = TRIP</p> <p>ELSE IF <i>Under Voltage Active</i> (10.016) = 1 THEN</p> <p>State = UNDER_VOLTAGE</p> <p>ELSE IF <i>Charge System Disabled / Contactor Closed</i> (03.008) = 0 OR</p> <p>Final drive enable = 0 THEN</p> <p>{</p> <p>mState = DISABLE</p> <p>Initiate (<i>Autotune Stopped</i>)</p> <p>}</p>	<p><i>Drive Active</i> (10.002) = 1</p> <p><i>Disable Charge System / Close Contactor</i> (03.007) = 1</p>	10 [Active]
TRIP	<p>IF Drive tripped = 0 THEN</p> <p>State = DISABLE</p> <p>ELSE IF <i>Under Voltage Active</i> (10.016) = 0 THEN</p> <p>State = TRIP_WITH_UNDER_VOLTAGE</p>	<p><i>Drive Active</i> (10.002) = 0</p> <p><i>Disable Charge System / Close Contactor</i> (03.007) = 1</p>	9 [Trip]
TRIP_WITH_UNDER_VOLTAGE	<p>IF Drive tripped = 0 THEN</p> <p>State = UNDER_VOLTAGE</p>	<p><i>Drive Active</i> (10.002) = 0</p> <p><i>Disable Charge System / Close Contactor</i> (03.007) = 0</p>	9 [Trip]

Parameter	06.015 Drive Enable		
Short description	Set to 1 to enable the drive		
Mode	Regeneration		
Minimum	0	Maximum	1
Default	1	Units	
Type	1 Bit User Save	Update Rate	2ms read
Display Format	Standard	Decimal Places	0
Coding	RW, BU		

Drive Enable (06.015) must be active for the drive to be enabled. See description of enable logic.

Parameter	06.016 Date		
Short description	Displays the current date		
Mode	Regeneration		
Minimum	0 (Display: 00-00-00)	Maximum	311299 (Display: 31-12-99)
Default		Units	
Type	32 Bit Volatile	Update Rate	Background read/write
Display Format	Date	Decimal Places	0
Coding	RW, ND, NC, PT		

Date (06.016), *Time* (06.017) and *Day Of Week* (06.018) show the date and time as selected by *Date/Time Selector* (06.019). *Date* (06.016) stores the date in dd.mm.yy format regardless of the setting made in *Date Format* (06.020) however if the parameter is viewed using a keypad the date will be displayed in the format selected in *Date Format* (06.020). If a real time clock is selected from an option module then the days, months and years are from the real time clock and the day of the week is displayed in *Day Of Week* (06.018). Otherwise the days have a minimum value of 0 and roll over after 30, the months have a minimum value of 0 and roll over after 11, and *Day Of Week* (06.018) is always 0 (Sunday).

If when setting the date/time this parameter is being written via comms or from an applications module then the value should be written in standard dd/mm/yy format as described below.

The value of this parameter as seen over comms or to an applications module is as follows.

Value = (day[1..31] x 10000) + (month[1..12] x 100) + year[0..99]

Parameter	06.017 Time		
Short description	Displays the current time		
Mode	Regeneration		
Minimum	0 (Display: 00:00:00)	Maximum	235959 (Display: 23:59:59)
Default		Units	
Type	32 Bit Volatile	Update Rate	Background read/write
Display Format	Time	Decimal Places	0
Coding	RW, ND, NC, PT		

See *Date* (06.016).

The value of this parameter as seen over comms or to an applications module is as follows.

Value = (hour[0..23] x 10000) + (minute[0..59] x 100) + seconds[0..59]

Parameter	06.018 Day Of Week		
Short description	Displays the current day of the week		
Mode	Regeneration		
Minimum	0	Maximum	6
Default		Units	
Type	8 Bit Volatile	Update Rate	Background write
Display Format	Standard	Decimal Places	0
Coding	RO, TE, ND, NC, PT		

Value	Text
0	Sunday
1	Monday
2	Tuesday
3	Wednesday
4	Thursday
5	Friday
6	Saturday

See *Date* (06.016).

Parameter	06.019 Date/Time Selector		
Short description	Defines which clock is used to display the current time, date and day of the week		
Mode	Regeneration		
Minimum	0	Maximum	5
Default	1	Units	
Type	8 Bit User Save	Update Rate	Background read
Display Format	Standard	Decimal Places	0
Coding	RW, TE		

Value	Text
0	Set
1	Powered
2	Running
3	Acc Powered
4	Local Keypad
5	Remote Keypad

Date/Time Selector (06.019) is used to select the drive date and time as shown in the table below.

Date/Time Selector (06.019)	Date/Time Source
0: Set	Date and time parameters can be written by the user.
1: Power	Time since the drive was powered up.
2: Running	Accumulated drive running time since the drive was manufactured.
3: Acc Power	Accumulated powered-up time since the drive was manufactured.
4: Local Keypad	If a keypad fitted to the front of the drive includes a real-time clock then the date/time from this clock is displayed, otherwise the date/time is set to zero.
5: Remote Keypad	If a keypad connected to the user comms port of a drive with a 485 includes a real-time clock then the date/time from this clock is displayed, otherwise the date/time is set to zero.

When *Date/Time Selector* (06.019) = 0 the *Date* (06.016) and *Time* (06.017) can be written by the user and the values in these parameters are transferred to the real time clocks in keypads that support this feature that are fitted to the drive. When *Date/Time Selector* (06.019) is changed to any other value, the real time clocks are allowed to run normally again. When *Date/Time Selector* (06.019) is changed from any value to 0 the date and time from a real time clock, if present, is automatically loaded into *Date* (06.016) and *Time* (06.017), so that this date and time is used as the initial value for editing. If more than one real time clock is present the date/time from the local keypad is used, if present.

Date (06.016) and *Time* (06.017) are used by the timers in Menu 09 and for time stamping trips. These features will continue to use the originally selected clock even if *Date/Time Selector* (06.019) is changed until a drive reset is initiated. If *Date/Time Selector* (06.019) has been changed and a reset is initiated *Timer 1 Repeat Function* (09.039) and *Timer 2 Repeat Function* (09.049) are set to zero to disable the timers, and the trip dates and times (10.041 to 10.060) are reset to zero.

Parameter	06.020 Date Format		
Short description	Defines if the US date format is used or not		
Mode	Regeneration		
Minimum	0	Maximum	1
Default	0	Units	
Type	8 Bit User Save	Update Rate	Background read
Display Format	Standard	Decimal Places	0
Coding	RW, TE		

Value	Text
0	Std
1	US

Date Format (06.020) selects the display style for *Date* (06.016), *Timer 1 Start Date* (09.035), *Timer 1 Stop Date* (09.037), *Timer 2 Start Date* (09.045), *Timer 2 Stop Date* (09.047), and for the trip time stamping date parameters (10.041, 10.043, 10.045, 10.047, 10.049, 10.051, 10.053, 10.055, 10.057 and 10.059) when displayed on a keypad connected to the drive. The format selection made in this parameter does not affect the value of these parameters if they are read using comms or by an applications program.

If *Date Format* (06.020) is 0 then standard format is used and the date is displayed on the keypad as dd.mm.yy and if *Date Format* (06.020) is 1 then US format is used and the date is displayed on the keypad as mm.dd.yy.

Parameter	06.021 Time Between Filter Changes		
Short description	Defines the time between filter changes		
Mode	Regeneration		
Minimum	0	Maximum	30000
Default	0	Units	Hours
Type	16 Bit User Save	Update Rate	Background read
Display Format	Standard	Decimal Places	0
Coding	RW		

Time Between Filter Changes (06.021) should be set to a non-zero value to enable the filter change timer system. Each time *Filter Change Required / Change Done* (06.022) is changed by the user from 1 to 0 the value of *Time Between Filter Changes* (06.021) is copied to

Time Before Filter Change Due (06.023). For each hour while *Drive Active* (10.002) = 1 the *Time Before Filter Change Due* (06.023) is reduced by 1 until it reaches zero. When *Time Before Filter Change Due* (06.023) reaches 0 *Filter Change Required / Change Done* (06.022) is set to 1 to indicate that a filter change is required. The filter should be changed and the system reset again by resetting *Filter Change Required / Change Done* (06.022) to 0.

When a non-zero value is written to *Time Between Filter Changes* (06.021) to enable the system, *Filter Change Required / Change Done* (06.022) should be set to 1 and then back to 0 to transfer the required time to *Time Before Filter Change Due* (06.023) and to enable the count down.

Parameter	06.022 Filter Change Required / Change Done		
Short description	Set to 0 when a filter change has taken place		
Mode	Regeneration		
Minimum	0	Maximum	1
Default		Units	
Type	1 Bit Volatile	Update Rate	Background read/write
Display Format	Standard	Decimal Places	0
Coding	RW, ND, NC		

See *Time Between Filter Changes* (06.021).

Parameter	06.023 Time Before Filter Change Due		
Short description	Displays the time before a filter change is required		
Mode	Regeneration		
Minimum	0	Maximum	30000
Default		Units	Hours
Type	16 Bit Power Down Save	Update Rate	Background write
Display Format	Standard	Decimal Places	0
Coding	RO, ND, NC, PT		

See *Time Between Filter Changes* (06.021).

Parameter	06.024 Reset Energy Meter		
Short description	Set to 1 to reset the energy meter		
Mode	Regeneration		
Minimum	0	Maximum	1
Default	0	Units	
Type	1 Bit Volatile	Update Rate	Background read
Display Format	Standard	Decimal Places	0
Coding	RW		

Energy Meter: MWh (06.025) and *Energy Meter: kWh* (06.026) accumulate the energy transferred through the drive. If *Reset Energy Meter* (06.024) = 1 then *Energy Meter: MWh* (06.025) and *Energy Meter: kWh* (06.026) are held at zero. If *Reset Energy Meter* (06.024) = 0 then the energy meter is enabled and will accumulate the energy flow. If the maximum or minimum of *Energy Meter: MWh* (06.025) is reached the parameter does not rollover and is instead clamped at the maximum or minimum value. For Open-loop, RFC-A and RFC-S modes a positive energy flow indicates that power is flowing out of the a.c. motor terminals. For Regen mode a positive energy flow indicates that power is flowing from the supply to the a.c. drive terminals.

Parameter	06.025 Energy Meter: MWh		
Short description	Displays the energy accumulated by through the drive in MWh		
Mode	Regeneration		
Minimum	-999.9	Maximum	999.9
Default		Units	MWh
Type	16 Bit Power Down Save	Update Rate	Background write
Display Format	Standard	Decimal Places	1
Coding	RO, ND, NC, PT		

See *Reset Energy Meter* (06.024).

Parameter	06.026 Energy Meter: kWh		
Short description	Displays the energy accumulated by through the drive in kWh		
Mode	Regeneration		
Minimum	-99.99	Maximum	99.99
Default		Units	kWh
Type	16 Bit Power Down Save	Update Rate	Background write
Display Format	Standard	Decimal Places	2
Coding	RO, ND, NC, PT		

See *Reset Energy Meter* (06.024).

Parameter	06.027 Energy Cost Per kWh		
Short description	Defines the cost of energy per kWh		
Mode	Regeneration		
Minimum	0.0	Maximum	600.0
Default	0.0	Units	
Type	16 Bit User Save	Update Rate	Background read
Display Format	Standard	Decimal Places	1
Coding	RW		

Running Cost (06.028) is derived from the *Output Power* (05.003) and the *Energy Cost Per kWh* (06.027) in cost per hour. The sign of *Running Cost* (06.028) is the same as the sign of *Output Power* (05.003).

Parameter	06.028 Running Cost		
Short description	Displays the running cost of the drive		
Mode	Regeneration		
Minimum	-32000	Maximum	32000
Default		Units	
Type	16 Bit Volatile	Update Rate	Background write
Display Format	Standard	Decimal Places	0
Coding	RO, ND, NC, PT		

See *Energy Cost Per kWh* (06.027).

Parameter	06.029 Hardware Enable		
Short description	Set to 1 to enable the hardware of the drive		
Mode	Regeneration		
Minimum	0	Maximum	1
Default		Units	
Type	1 Bit Volatile	Update Rate	2ms read
Display Format	Standard	Decimal Places	0
Coding	RO, ND, NC, PT		

Hardware Enable (06.029) normally shows the hardware enable state based on the state of the safe torque off system. However, drive I/O can be routed to *Hardware Enable* (06.029) to reduce the disable time. See description of the enable logic for more details.

Parameter	06.041 Drive Event Flags		
Short description	Displays if certain actions have occurred within the drive		
Mode	Regeneration		
Minimum	0 (Display: 00)	Maximum	3 (Display: 11)
Default	0 (Display: 00)	Units	
Type	8 Bit Volatile	Update Rate	Background write
Display Format	Binary	Decimal Places	0
Coding	RW, NC		

Drive Event Flags (06.041) indicates that certain actions have occurred within the drive as described below.

Bit	Corresponding event
0	Defaults loaded
1	Drive mode changed

Bit 0: Defaults loaded

The drive sets bit 0 when defaults have been loaded and the associated parameter save has been completed. The drive does not reset this flag except at power-up.

Bit 1: Drive mode changed

The drive sets bit 1 when the drive mode has changed and the associated parameter save has been completed. The drive does not reset this flag except at power-up.

Parameter	06.042 Control Word		
Short description	Controls the sequencer state machine inputs if the control word is enabled		
Mode	Regeneration		
Minimum	0 (Display: 0000000000000000)	Maximum	32767 (Display: 1111111111111111)
Default	0 (Display: 0000000000000000)	Units	
Type	16 Bit Volatile	Update Rate	Bits 9,7-0: 2ms read, Other bits: Background read
Display Format	Binary	Decimal Places	0
Coding	RW, NC		

If *Control Word Enable* (06.043) = 0 then *Control Word* (06.042) has no effect. If *Control Word Enable* (06.043) = 1 the bits in *Control Word* (06.042) are

used instead of their corresponding parameters or to initiate drive functions as shown in the table below.

Bit	Corresponding parameter or function
0	Drive Enable (06.015)
1	Not used
2	Not used
3	Not used
4	Not used
5	Not used
6	Not used
7	Auto/manual
8	Analogue/Preset reference
9	Not used
10	Not used
11	Not used
12	Trip drive
13	Reset drive
14	Watchdog

Bits 0-7 and bit 9: Sequencer control

When Auto/manual bit (bit7) = 1 then bit 0 of the *Control Word* (06.042) becomes active. The equivalent parameters are not modified by these bits, but become inactive when the equivalent bits in the *Control Word* (06.042) are active. When the bits are active they replace the functions of the equivalent parameters.

Bit 8: Analogue/preset reference

The value of this bit has no effect on the drive.

Bit 10 and bit 11: Not used

The values of these bits have no effect on the drive.

Bit 12: Trip drive

If bit 12 = 1 then a *Control Word* trip is repeatedly initiated. The trip cannot be cleared until bit 12 = 0.

Bit 13: Reset drive

If bit 13 is changed from 0 to 1 a drive reset is initiated. Bit 13 does not modify *Drive Reset* (10.033).

Bit 14: Watchdog

A watchdog system can be enabled or serviced each time bit 14 is changed from 0 to 1. Once bit 14 has been changed from 0 to 1 to enable the watchdog, this must be repeated every 1s or else a *Watchdog* trip will be initiated. The watchdog is disabled when the trip occurs and must be re-enabled if required when the trip is reset.

Parameter	06.043 Control Word Enable		
Short description	Set to 1 to enable the control word		
Mode	Regeneration		
Minimum	0	Maximum	1
Default	0	Units	
Type	1 Bit User Save	Update Rate	2ms read
Display Format	Standard	Decimal Places	0
Coding	RW		

See *Control Word* (06.042).

Parameter	06.044 Active Supply		
Short description	Indicates when the backup supply mode is enabled and the dc link voltage is below the upper under voltage threshold		
Mode	Regeneration		
Minimum	0	Maximum	1
Default		Units	
Type	1 Bit Volatile	Update Rate	Background write
Display Format	Standard	Decimal Places	0
Coding	RO, ND, NC, PT		

If *Backup Supply Mode Enable* (06.068) = 0 then *Active Supply* (06.044) = 0. If *Backup Supply Mode Enable* (06.068) = 1 then *Active Supply* (06.044) = 0 when the d.c. link voltage is above the upper under-voltage threshold otherwise it is one. In Regen mode *Active Supply* (06.044) is always zero.

Parameter	06.045 Cooling Fan control		
Short description	Defines the maximum speed of the drive cooling fan		
Mode	Regeneration		
Minimum	-10	Maximum	11
Default	-10	Units	
Type	8 Bit User Save	Update Rate	Background read
Display Format	Standard	Decimal Places	0
Coding	RW		

Cooling Fan control (06.045) can be used to select various fan control functions as shown in the table below. The actual control speed of the fan(s) is given in Cooling Fan Speed (06.046). There are 10 control speeds for the fan(s) in the drive, however the actual hardware control is more coarse than this, and so there may not be an actual change of fan speed as Cooling Fan Speed (06.046) changes from one value to the next. The default value for Cooling Fan control (06.045) is 10, which gives maximum cooling and does not limit the fan speed below its maximum. It should be noted that if the speed is limited, by setting a lower value, then the drive may trip prematurely under load.

Cooling Fan control (06.045)	Function Selected
-10 to -1	Minimum fan noise function with fan speed limited to the value of Cooling Fan control (06.045).
0	Fan does not run.
1 to 10	Maximum cooling with fan speed limited to the modulus of Cooling Fan control (06.045).
11	Fan runs continuously at full speed.

The two possible control characteristics are shown in the diagram below.

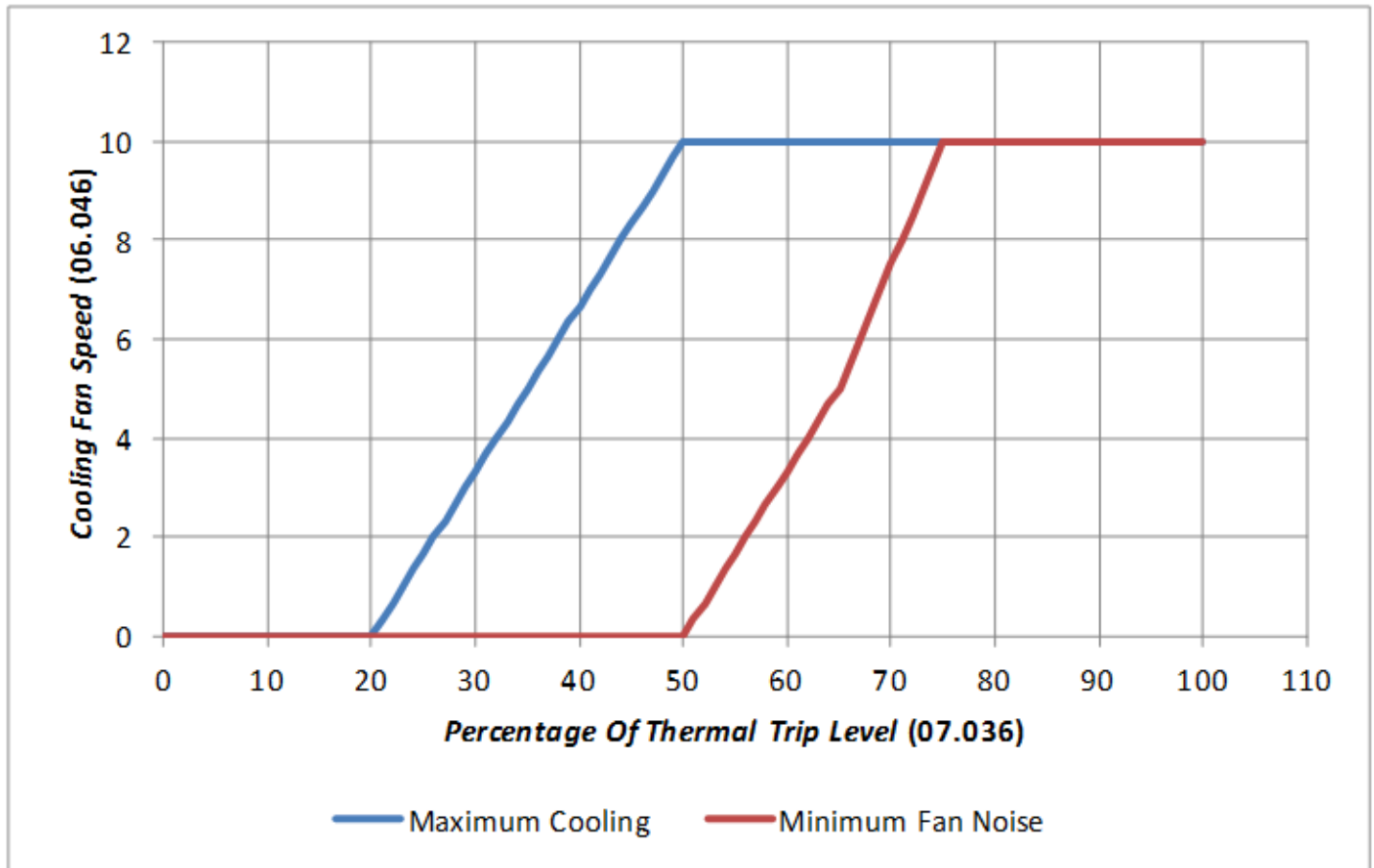

The fan speed is derived from Percentage Of Drive Thermal Trip Level (07.036) which shows the percentage to the trip level of the hottest monitored point in the drive. The "Maximum Cooling" characteristic brings the fan(s) on at a relatively low temperature to give maximum cooling. The "Minimum Fan Noise" characteristic does not switch on the fan(s) until the drive temperature has risen significantly, and the characteristic has a lower gradient. Therefore with lighter continuous loads the fan noise is kept to a minimum. This characteristic also prevents the fan(s) from coming on when the drive is disabled and operating in a high ambient. With both characteristics a filter is applied to Percentage Of Drive Thermal Trip Level (07.036) to avoid the fans switching on and off during short high transient loads. The "Minimum Fan Noise" characteristic also includes a hysteresis band of 15% that is applied to the percentage of drive thermal trip level at the input to the control algorithm to prevent the feedback from changing the speed back again. This reduces the chance of the fan repetitively changing speed under constant load conditions.

Parameter	06.046 Cooling Fan Speed		
Short description	Cooling Fan Speed		
Mode	Regeneration		
Minimum	0	Maximum	10
Default		Units	
Type	8 Bit Volatile	Update Rate	Background Write
Display Format	Standard	Decimal Places	0
Coding	RO, ND, NC, PT		

See Cooling Fan control (06.045).

Parameter	06.060 Standby Mode Enable		
Short description	Set to 1 enable standby mode		
Mode	Regeneration		
Minimum	0	Maximum	1
Default	0	Units	
Type	1 Bit User Save	Update Rate	Background read
Display Format	Standard	Decimal Places	0
Coding	RW		

If *Standby Mode Enable* (06.060) = 1 then the drive will go into the standby power state whenever *Drive Active* (10.002) = 0 with a delay of 30s. In this state the LED on the front of the drive flashes 0.5s on and 5s off, the drive cannot be enabled and the following actions are taken as defined by the *Standby Mode Mask* (06.061). Actions are enabled by setting the appropriate bit to 1. Once standby mode has become active it will remain active, even if an attempt is made subsequently to enable the drive, until *Standby Mode Enable* (06.060) is set to 0.

Standby Mode Mask (06.061) bits	Action
0	Turn off the drive position feedback power supply. On leaving standby mode the drive position feedback interfaces will be re-initialised.
1	Turn off the power supply to a keypad fitted to the drive.
2	Turn off the drive 24V output.
3	Request that the option module in option slot 1 to go into the standby power mode
4	Request that the option module in option slot 2 to go into the standby power mode
5	Request that the option module in option slot 3 to go into the standby power mode
6	Request that the option module in option slot 4 to go into the standby power mode

Parameter	06.061 Standby Mode Mask		
Short description	Defines the actions of the drive with standby mode is enabled		
Mode	Regeneration		
Minimum	0 (Display: 0000000)	Maximum	127 (Display: 1111111)
Default	0 (Display: 0000000)	Units	
Type	8 Bit User Save	Update Rate	Background read
Display Format	Binary	Decimal Places	0
Coding	RW, BU		

See *Standby Mode Enable* (06.060).

Parameter	06.065 Standard Under Voltage Threshold		
Short description	Defines the standard under voltage threshold		
Mode	Regeneration		
Minimum	0	Maximum	VM_STD_UNDER_VOLTS
Default	See exceptions below	Units	V
Type	16 Bit User Save	Update Rate	Background read
Display Format	Standard	Decimal Places	0
Coding	RW, VM, RA, BU		

Voltage	Default Value
200V	175
400V	330
575V	435
690V	435

Under-voltage and power supply control

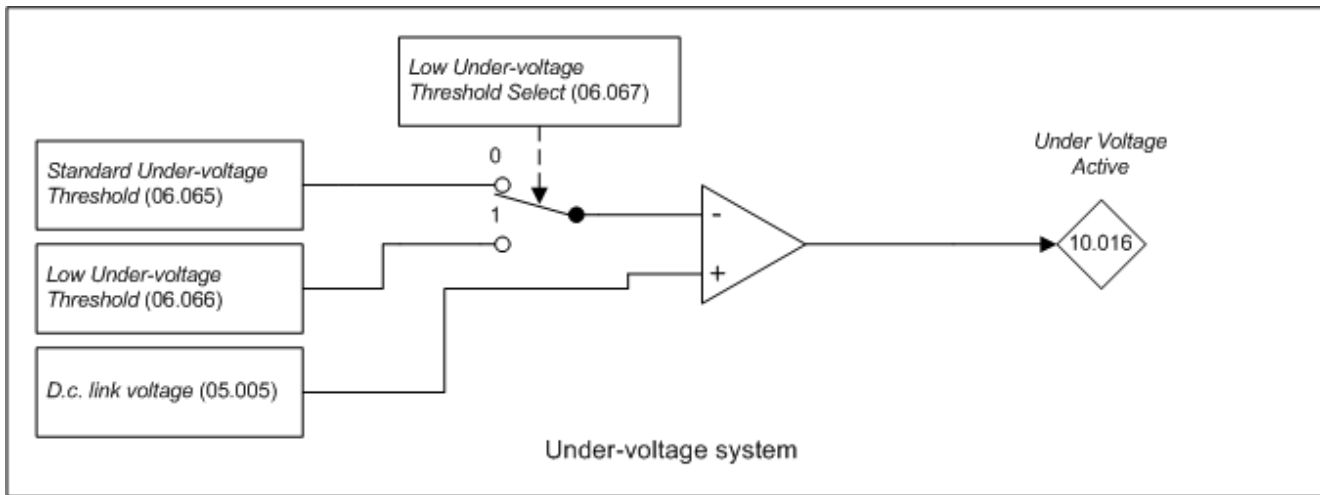

Under-voltage system

The under-voltage system controls the state of *Under Voltage Active* (10.016) which is then used by the sequencer state machine. Each under voltage threshold detection system includes hysteresis of 5% of the actual threshold level therefore:

D.c. Bus Voltage (05.005)	Under voltage detection
Vdc	Active
Threshold \leq Vdc	No change
Vdc \geq Threshold x 1.05*	Not active

* Hysteresis is 5% subject to a minimum of 5V

When *Under Voltage Active* (10.016) = 1 the sequencer state machine will change to the UNDER_VOLTAGE state and when the UNDER_VOLTAGE state is active it is not possible to enable the drive inverter.

If the low under-voltage threshold is used the internal drive power supplies are normally powered from the 24V supply input (i.e. Digital I/O 13). *User Supply Select* (06.072) should be set to one to select this supply and its monitoring system.

If *Low Under Voltage Threshold Select* (06.067) = 0 then the under voltage threshold is defined by *Standard Under Voltage Threshold* (06.065). If *Low Under Voltage Threshold Select* (06.067) = 1 then the under voltage threshold is defined by *Low Under Voltage Threshold* (06.066).

Parameter	06.066 Low Under Voltage Threshold		
Short description	Defines the low under voltage threshold		
Mode	Regeneration		
Minimum	0	Maximum	VM_LOW_UNDER_VOLTS
Default	330	Units	V
Type	16 Bit User Save	Update Rate	Background read
Display Format	Standard	Decimal Places	0
Coding	RW, VM, RA, BU		

See *Standard Under Voltage Threshold* (06.065).

Parameter	06.067 Low Under Voltage Threshold Select		
Short description	Set to 1 to use the low under voltage threshold		
Mode	Regeneration		
Minimum	0	Maximum	1
Default	0	Units	
Type	1 Bit User Save	Update Rate	Background read
Display Format	Standard	Decimal Places	0
Coding	RW		

See *Standard Under Voltage Threshold* (06.065). Also see *User Supply Select* (06.072) for details of when and how drive parameters can be saved, and when a *User 24V* trip can occur.

Parameter	06.073 Braking IGBT Lower Threshold		
Short description	Defines the lowest level of the d.c. bus voltage where the braking IGBT becomes active		
Mode	Regeneration		
Minimum	0	Maximum	VM_DC_VOLTAGE_SET
Default	See exceptions below	Units	V
Type	16 Bit User Save	Update Rate	4ms read
Display Format	Standard	Decimal Places	0
Coding	RW, VM, RA, BU		

Voltage	Default Value
200V	390
400V	780
575V	930
690V	1120

Braking IGBT Lower Threshold (06.073) defines the lowest level of *D.c. Bus Voltage* (05.005) where the braking IGBT will become active and *Braking IGBT Upper Threshold* (06.074) defines the level of *D.c. Bus Voltage* (05.005) where the braking IGBT will be on continuously. When the braking IGBT is turned on it will remain on for at least 1ms. The braking IGBT on-time is defined by the thresholds and the d.c. link voltage as given in the table below where L = *Braking IGBT Lower Threshold* (06.073) and U = *Braking IGBT Upper Threshold* (06.074).

D.c. link voltage level	On-time
<i>D.c. Bus Voltage</i> (05.005)	0%
$L \leq D.c. Bus Voltage (05.005)$	$[(D.c. Bus Voltage (05.005) - L) / (U - L)] \times 100\%$
$D.c. Bus Voltage (05.005) \geq U$	100%

As the *D.c. Bus Voltage* (05.005) rises above the lower threshold the braking IGBT is active with an on/off ratio of 1/100. As the voltage rises further, the on/off ratio increases until at the upper threshold the braking IGBT is on continuously. The upper and lower voltage threshold can be set up so that braking resistors in drives with parallel connected d.c. links will share the braking load.

If *Braking IGBT Lower Threshold* (06.073) \geq *Braking IGBT Upper Threshold* (06.074) then the braking IGBT is off when *D.c. Bus Voltage* (05.005) < *Braking IGBT Upper Threshold* (06.074) and on if *D.c. Bus Voltage* (05.005) \geq *Braking IGBT Upper Threshold* (06.074). This method of control is the same as that used in Unidrive SP and the default values for the braking thresholds are equal to the braking thresholds in Unidrive SP.

Unless sharing between braking resistors is required the braking thresholds do not normally need to be adjusted. Care should be taken when reducing the thresholds because if either threshold is below the maximum value of the peak rectified supply voltage the braking resistor could take power from the supply.

The list below gives conditions that will disable the braking IGBT:

1. *Braking IGBT Upper Threshold* (06.074) = 0, or *Low Voltage Braking IGBT Threshold Select* (06.076) = 1 and *Low Voltage Braking IGBT Threshold* (06.075) = 0.
2. The drive is in the under-voltage state.
3. A priority 1, 2 or 3 trip is active (see *Trip 0* (10.020)).
4. One of the following trips is active or would be active if another trip is not already active: *OI Brake*, *PSU*, *Th Brake Res* or *Oht Inverter*.
5. *Percentage Of Drive Thermal Trip Level* (07.036) = 100%. This is an indication that some part of the drive is too hot and is used to indicate if an internally fitted braking resistor is too hot.
6. *Brake R Too Hot* is active or the system has been set up to disable the braking IGBT based on the braking resistor temperature and the resistor is too hot (i.e. bit 2 of *Action On Trip Detection* (10.037) is set).

Parameter	06.074 <i>Braking IGBT Upper Threshold</i>		
Short description	Defines the level of the d.c. bus voltage where the braking IGBT will be on continuously		
Mode	Regeneration		
Minimum	0	Maximum	VM_DC_VOLTAGE_SET
Default	See exceptions below	Units	V
Type	16 Bit User Save	Update Rate	4ms read
Display Format	Standard	Decimal Places	0
Coding	RW, VM, RA, BU		

Voltage	Default Value
200V	390
400V	780
575V	930
690V	1120

See *Braking IGBT Lower Threshold* (06.073).

Parameter	06.075 <i>Low Voltage Braking IGBT Threshold</i>		
Short description	Defines the threshold used for low voltage braking		
Mode	Regeneration		
Minimum	0	Maximum	VM_DC_VOLTAGE_SET
Default	0	Units	V
Type	16 Bit User Save	Update Rate	4ms read
Display Format	Standard	Decimal Places	0
Coding	RW, VM, RA, BU		

If *Low Voltage Braking IGBT Threshold Select* (06.076) = 0 the normal thresholds are used. If *Low Voltage Braking IGBT Threshold Select* (06.076) = 1 then *Low Voltage Braking IGBT Threshold* (06.075) is used, so that the braking IGBT is on with a minimum on time of 1ms if the d.c. link voltage is above this level, or off if the d.c. link voltage is below this level.

Parameter	06.076 Low Voltage Braking IGBT Threshold Select		
Short description	Set to 1 enable low voltage IGBT braking		
Mode	Regeneration		
Minimum	0	Maximum	1
Default	0	Units	
Type	1 Bit Volatile	Update Rate	4ms read
Display Format	Standard	Decimal Places	0
Coding	RW		

See *Low Voltage Braking IGBT Threshold* (06.075).

Parameter	06.084 Date And Time Offset		
Short description	Date And Time Offset		
Mode	Regeneration		
Minimum	-12.00	Maximum	12.00
Default	0.00	Units	Hours
Type	16 Bit User Save	Update Rate	Background Read
Display Format	Standard	Decimal Places	2
Coding	RW		

Date And Time Offset (06.084) is an offset, specified in hours, that can be applied to the *Time* (06.017). If the offset applied causes the time to roll-over midnight then the *Date* (06.016) and *Day Of Week* (06.018) are also modified. The offset is only applied when the clock source is a clock derived from a keypad, i.e. *Date/Time Selector* (06.019) > 3. The offset can be used for time zone offsets or daylight saving time etc.

Menu 7 Single Line Descriptions – Analog I/O

Mode: Regeneration

Parameter		Range	Default	Type					
07.001	Analog Input 1	±100.00 %		RO	Num	ND	NC	PT	FI
07.004	Monitored Temperature 1	±250 °C		RO	Num	ND	NC	PT	
07.005	Monitored Temperature 2	±250 °C		RO	Num	ND	NC	PT	
07.006	Monitored Temperature 3	±250 °C		RO	Num	ND	NC	PT	
07.008	Analog Input 1 Scaling	0.000 to 10.000	1.000	RW	Num				US
07.009	Analog Input 1 Invert	Off (0) or On (1)	Off (0)	RW	Bit				US
07.010	Analog Input 1 Destination	0.000 to 59.999	0.000	RW	Num	DE		PT	US
07.025	Calibrate Analog Input 1 Full Scale	Off (0) or On (1)	Off (0)	RW	Bit		NC		
07.026	Analogue Input 1 Fast Update Active	Off (0) or On (1)		RO	Bit	ND	NC	PT	
07.030	Analog Input 1 Offset	±100.00 %	0.00 %	RW	Num				US
07.033	Power Output	±100.0 %		RO	Num	ND	NC	PT	
07.034	Inverter Temperature	±250 °C		RO	Num	ND	NC	PT	
07.035	Percentage Of d.c. Link Thermal Trip Level	0 to 100 %		RO	Num	ND	NC	PT	
07.036	Percentage Of Drive Thermal Trip Level	0 to 100 %		RO	Num	ND	NC	PT	
07.037	Temperature Nearest To Trip Level	0 to 20999		RO	Num	ND	NC	PT	
07.038	Temperature Monitor Select 1	0 to 1999	1001	RW	Num				US
07.039	Temperature Monitor Select 2	0 to 1999	1002	RW	Num				US
07.040	Analog Input 1 Minimum	±100.00 %	-100.00 %	RW	Num				US
07.043	Analog Input 1 Maximum	±100.00 %	100.00 %	RW	Num				US
07.051	Analog Input 1 Full Scale	0 to 65535		RO	Num	ND	NC	PT	PS
07.052	Temperature Monitor Select 3	0 to 1999	1	RW	Num				US

RW	Read / Write	RO	Read-only	Bit	Bit parameter	Txt	Text string	Date	Date parameter	Time	Time parameter
Chr	Character parameter	Bin	Binary parameter	IP	IP address	Mac	MAC address	Ver	Version number	SMP	Slot, menu, parameter
Num	Number parameter	DE	Destination	ND	No default value	RA	Rating dependent	NC	Non-copyable	PT	Protected
FI	Filtered	US	User save	PS	Power-down save						

Menu 7 – Analog I/O

Mode: Regeneration

Analog Outputs

The update rate for analog outputs is 250µs; although the output will only change at the update rate defined by the source parameter for the input. The following exceptions apply:

1. *Speed Feedback* (03.002) has an update rate of 4ms and includes a 16ms window filter. If this parameter is selected as a source for output 2 the update rate of the source changes to 250µs and the only filter applied is the window filter associated with the position feedback interface (i.e. *P1 Feedback Filter* (03.042) for the P1 interface). It should be noted that this feature is only provided when the position feedback is from a drive interface and not from an option module.
2. If either analogue output is set up for current mode then the update rate for both analogue outputs is 4ms.

Analog Inputs

The normal sample rate for the analog inputs is 4ms, however this is increased to 250µs for analogue inputs 1 and 2 under the following conditions:

1. The maximum and the minimum for the input are at their default values of 100.00% and -100.00% respectively.
2. The input is set to voltage mode.
3. One of the destinations given in the table below must be selected.
4. If the destination is *Analog Reference 1* (01.036) or *Analog Reference 2* (01.037) the reference system must not be in unipolar mode, i.e. *Bipolar Reference Enable* (01.010) must be one.

Note that *Analogue Input 1 Fast Update Active* (07.026) and *Analogue Input 2 Fast Update Active* (07.027) indicate if fast updating is active for each input.

Parameter	Drive modes	Comment
<i>Analog Reference 1</i> (01.036)	RFC-A, RFC-S	The data from <i>Analog Reference 1</i> (01.036) is processed in the 250µs task so that the reference to the speed controller is updated every 250µs.
<i>Analog Reference 2</i> (01.037)	RFC-A, RFC-S	The data from <i>Analog Reference 2</i> (01.037) is processed in the 250µs task so that the reference to the speed controller is updated every 250µs.
<i>Hard Speed Reference</i> (03.022)	RFC-A, RFC-S	
<i>Torque Reference</i> (04.008)	RFC-A, RFC-S	
<i>Power Input 1</i> (03.010) <i>Power Input 2</i> (03.013) <i>Power Input 3</i> (03.014)	Regen	

The diagram below shows the parameter structure for each I/O. See *Internal I/O Identifier* (11.068) for details of which I/O is present for different I/O options.

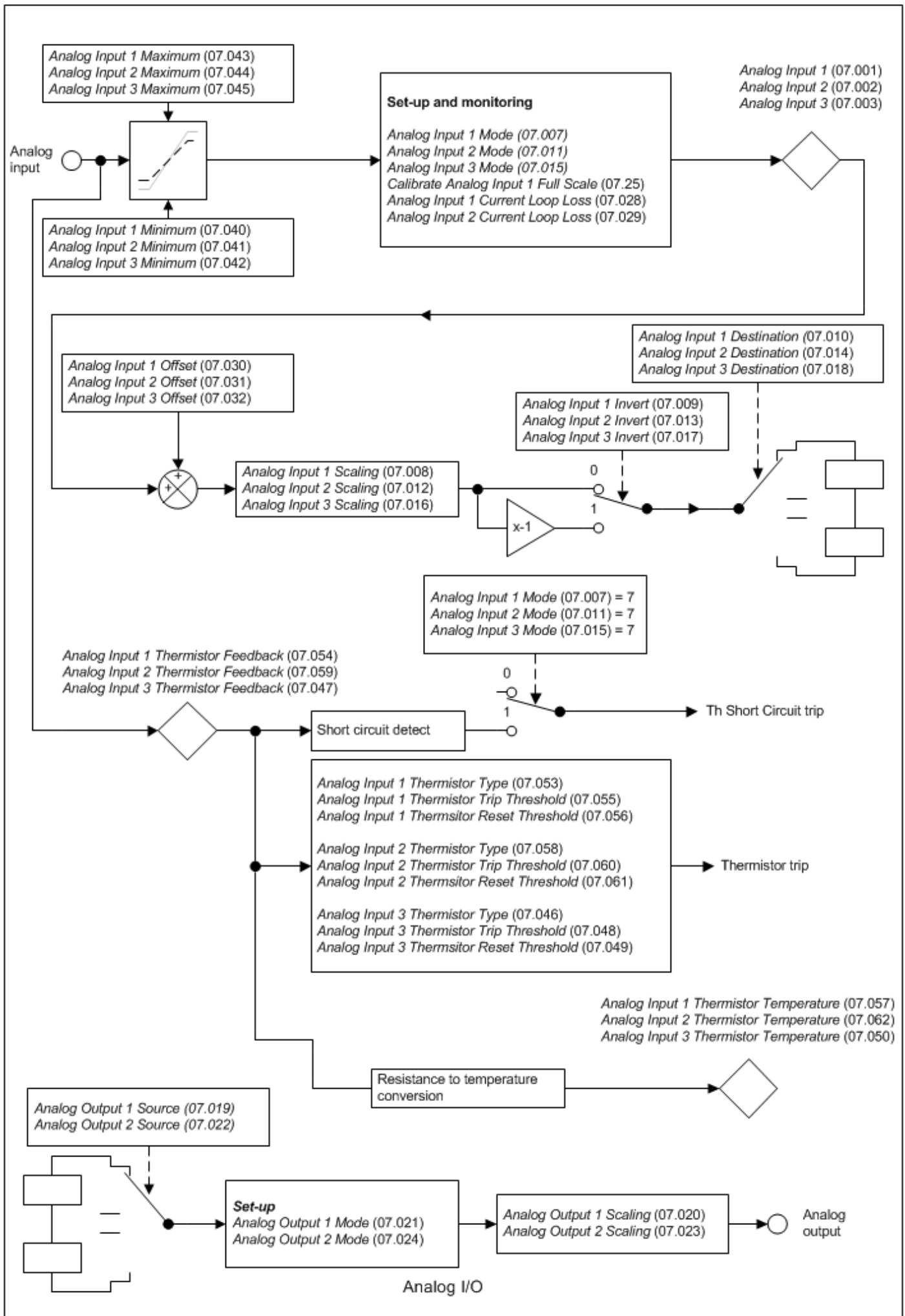

Parameter	07.001 Analog Input 1		
Short description	Displays the value of analog input 1		
Mode	Regeneration		
Minimum	-100.00	Maximum	100.00
Default		Units	%
Type	16 Bit Volatile	Update Rate	4ms write
Display Format	Standard	Decimal Places	2
Coding	RO, FI, ND, NC, PT		

Each analogue input has a resolution of 11 bits plus sign. The inputs can operate in different modes (defined by *Analog Input 1 Mode* (07.007) for analogue input 1). These modes include voltage, current and thermistor modes. The available modes depend on the hardware configuration and are given in the table below.

Internal I/O Identifier (11.068)	Analogue Input 1	Analogue Input 2	Analogue Input 3
0: Standard Analogue and Digital I/O	Bipolar Voltage, Current	Bipolar Voltage, Current	Bipolar Voltage, Thermistor
1: Digital I/O	Not present	Not present	Thermistor, Disabled
2: HVAC Analogue and Digital I/O	Unipolar Voltage, Current, Thermistor	Unipolar Voltage, Current, Thermistor	Not present

The "Input Level" is defined for the different modes in the table below.

Mode	Input Level
Voltage	(Input Voltage / 10V) x 100.00%
0-20mA	(Input Current / 20mA) x 100.00%
20-0mA	((20mA - Input Current) / 20mA) x 100.00%
4-20mA	((Input Current - 4mA) / 16mA) x 100.00%
20-4mA	((20mA - Input Current) / 16mA) x 100.00%
Thermistor	(Input resistance / 10K Ohm) x 100%

Analog Input 1 (07.001) is derived as follows:

Limits

A_1 is the value after the minimum and maximum limits are applied.

If *Analog Input 1 Minimum* (07.040) \geq *Analog Input 1 Maximum* (07.043) then:
 $A_1 = 0.00\%$ whatever the input level.

If *Analog Input 1 Minimum* (07.040) $< 0.00\%$ and *Analog Input 1 Maximum* (07.043) $> 0.00\%$ then:
 $A_1 = \text{Input Level} \times (100.00\% / \text{Analog Input 1 Maximum (07.043)})$
 A_1 is then limited between -100% and $+100\%$.

Otherwise:

Input Level is limited between *Analog Input 1 Minimum* (07.040) and *Analog Input 1 Maximum* (07.043)
 $A_1 = [\text{Input Level} - \text{Analog Input 1 Minimum (07.040)}] \times 100.00\% / (\text{Analog Input 1 Maximum (07.043)} - \text{Analog Input 1 Minimum (07.040)})$

For thermistor modes it should be noted that *Analog Input 1 Minimum* (07.040) and *Analog Input 1 Maximum* (07.043) have no effect and that the input resistance is limited between 0 and 5k Ω .

Parameter	07.004 Monitored Temperature 1		
Short description	Displays the temperature set up by Temperature Monitor Select 1		
Mode	Regeneration		
Minimum	-250	Maximum	250
Default		Units	$^{\circ}\text{C}$
Type	16 Bit Volatile	Update Rate	Background write
Display Format	Standard	Decimal Places	0
Coding	RO, ND, NC, PT		

Thermal monitoring is provided within the drive to protect the power stage and the control system from over temperature.

Monitored Temperature 1 (07.004), *Monitored Temperature 2* (07.005) and *Monitored Temperature 3* (07.006) give an indication of the temperature of three selected monitoring points within the drive power system or control system. The required monitoring points can be selected using *Temperature Monitor Select 1* (07.038), *Temperature Monitor Select 2* (07.039) and *Temperature Monitor Select 3* (07.052) respectively. The default values give two monitoring points in the power system in *Monitored Temperature 1* (07.004) and *Monitored Temperature 2* (07.005), and control board temperature 1 in *Monitored Temperature 3* (07.006).

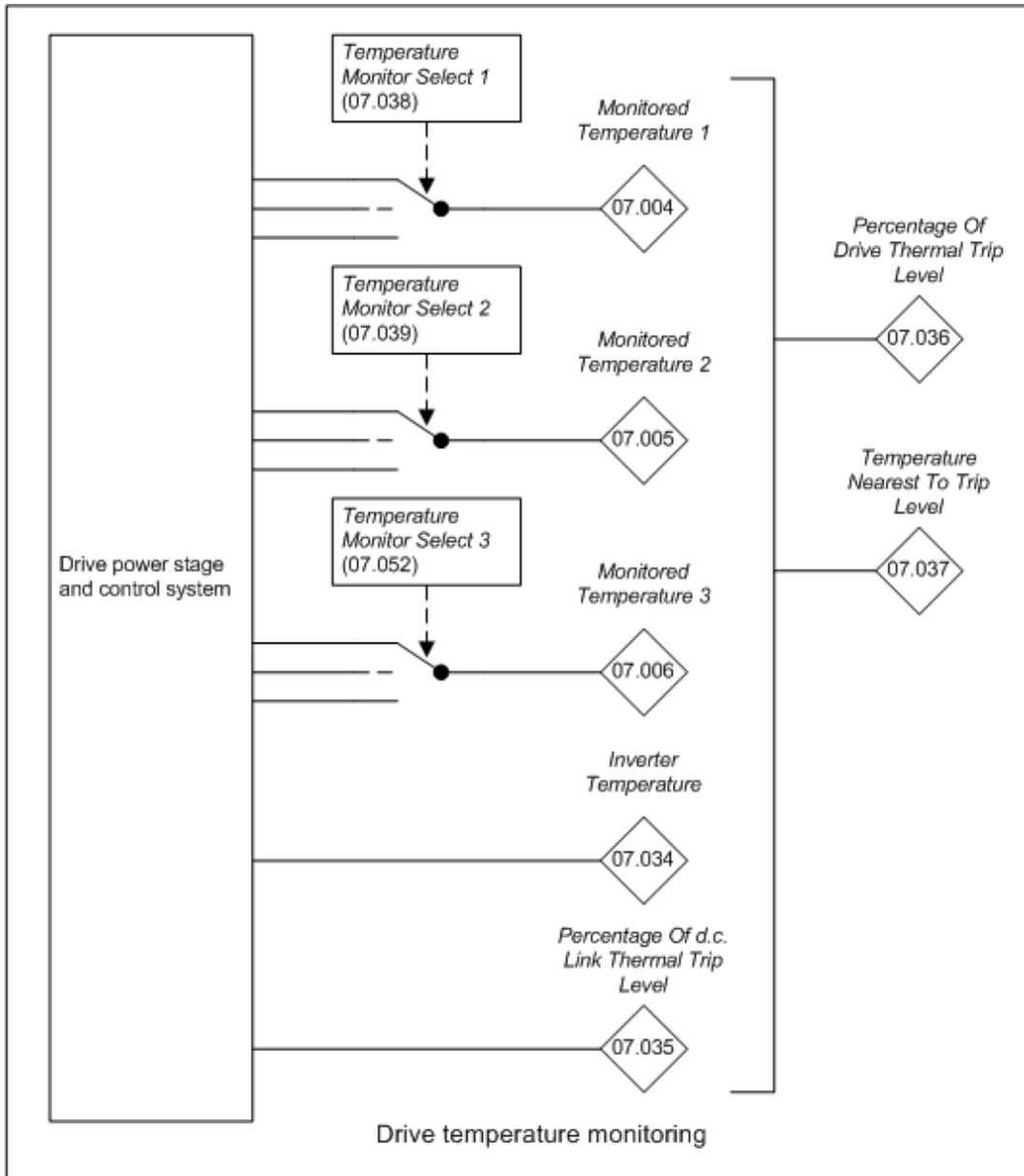

Parameter	07.005 Monitored Temperature 2		
Short description	Displays the temperature set up by Temperature Monitor Select 2		
Mode	Regeneration		
Minimum	-250	Maximum	250
Default		Units	°C
Type	16 Bit Volatile	Update Rate	Background write
Display Format	Standard	Decimal Places	0
Coding	RO, ND, NC, PT		

See *Monitored Temperature 1* (07.004) for details.

Parameter	07.006 Monitored Temperature 3		
Short description	Displays the temperature set up by Temperature Monitor Select 3		
Mode	Regeneration		
Minimum	-250	Maximum	250
Default		Units	°C
Type	16 Bit Volatile	Update Rate	Background write
Display Format	Standard	Decimal Places	0
Coding	RO, ND, NC, PT		

See *Monitored Temperature 1* (07.004) for details.

Parameter	07.008 Analog Input 1 Scaling		
Short description	Defines the scaling factor of analog input 1		
Mode	Regeneration		
Minimum	0.000	Maximum	10.000
Default	1.000	Units	
Type	16 Bit User Save	Update Rate	Background read
Display Format	Standard	Decimal Places	3
Coding	RW		

Analog Input 1 (07.001) is modified by *Analog Input 1 Scaling* (07.008), *Analog Input 1 Offset* (07.030) and *Analog Input 1 Invert* (07.009) before it is routed to its destination as follows:

$$A_{1O} = \text{Analog Input 1 (07.001)} + \text{Analog Input 1 Offset (07.030)}$$

A_{1O} is the value after the offset has been applied and is limited between -100.00% and 100.00%

$$A_{1S} = A_{1O} \times \text{Analog Input 1 Scaling (07.008)}$$

A_{1S} is the value after the scaling and the offset have been applied and is limited between -100.00% and 100.00%

If *Analog Input 1 Invert* (07.009) = 0 then $A_{1I} = A_{1S}$ otherwise $A_{1I} = -A_{1S}$

A_{1I} is the value after the invert, scaling and offset have been applied and is the final value that is routed to the destination defined by *Analog Input 1 Destination* (07.010).

Parameter	07.009 Analog Input 1 Invert		
Short description	Inverts the signal for analog input 1		
Mode	Regeneration		
Minimum	0	Maximum	1
Default	0	Units	
Type	1 Bit User Save	Update Rate	Background read
Display Format	Standard	Decimal Places	0
Coding	RW		

See *Analog Input 1 Scaling* (07.008).

Parameter	07.010 Analog Input 1 Destination		
Short description	Defines the output parameter for analog input 1		
Mode	Regeneration		
Minimum	0.000	Maximum	59.999
Default	0.000	Units	
Type	16 Bit User Save	Update Rate	Drive reset read
Display Format	Standard	Decimal Places	3
Coding	RW, DE, PT, BU		

See *Analog Input 1 Scaling* (07.008).

Parameter	07.025 Calibrate Analog Input 1 Full Scale		
Short description	Calibrates the input level for analog input 1		
Mode	Regeneration		
Minimum	0	Maximum	1
Default	0	Units	
Type	1 Bit Volatile	Update Rate	Background read
Display Format	Standard	Decimal Places	0
Coding	RW, NC		

For analog input 1, and in voltage mode only, the full scale value used to determine the input level can be changed from 10V by calibrating the input. The calibration process is triggered by setting *Calibrate Analog Input 1 Full Scale* (07.025) to one. *Calibrate Analog Input 1 Full Scale* (07.025) is cleared automatically when the calibration process is complete. After calibration the actions are as follows:

Input voltage during calibration	Result
$V < 1.5V$	The calibration result is ignored and the full scale is set to 10V. <i>Analog Input 1 Full Scale</i> (07.051) is set to zero.
$1.5V < V < 2.5V$	The calibration result is ignored and the full scale or <i>Analog Input 1 Full Scale</i> (07.051) are not affected.
$V > 2.5V$	The calibration result is used to set full scale and the value is also stored in <i>Analog Input 1 Full Scale</i> (07.051).

It should be noted that *Analog Input 1 Full Scale* (07.051) is a power-down save parameter, and so the result is automatically retained after power-down.

Parameter	07.026 Analogue Input 1 Fast Update Active		
Short description	Analogue Input 1 Fast Update Active		
Mode	Regeneration		
Minimum	0	Maximum	1
Default		Units	
Type	1 Bit Volatile	Update Rate	Background write
Display Format	Standard	Decimal Places	0
Coding	RO, ND, NC, PT		

Analogue Input 1 Fast Update Active (07.026) is one if the destination for analogue input 1 is being updated at the fast rate of 250us.

Parameter	07.030 Analog Input 1 Offset		
Short description	Defines the offset of analog input 1		
Mode	Regeneration		
Minimum	-100.00	Maximum	100.00
Default	0.00	Units	%
Type	16 Bit User Save	Update Rate	Background read
Display Format	Standard	Decimal Places	2
Coding	RW		

See *Analog Input 1 Scaling* (07.008).

Parameter	07.033 Power Output		
Short description	Instant output power		
Mode	Regeneration		
Minimum	-100.0	Maximum	100.0
Default		Units	%
Type	16 Bit Volatile	Update Rate	250µs write
Display Format	Standard	Decimal Places	1
Coding	RO, ND, NC, PT		

This is an instantaneous power output with fast update rate that is primarily intended to be used as a power feed-forward for applications with a Regen system front end. The full scale (100.0%) value is equal to a power of $3 \times (VM_DC_VOLTAGE[MAX] / 2\sqrt{2}) \times Full\ Scale\ Current\ Kc$ (11.061). This is compatible with the power output provided in Unidrive SP and is directly compatible with *Power Input 1* (03.010) (and the other power feed-forward parameters) in Regen mode. The scaling is intended to cover the maximum range of likely power in the drive. For example with a 400V 7.5kW drive the full scale d.c. link voltage is 831V and $Kc=38.222A$, and so the full scale value of this parameter is $3 \times (831 / 2\sqrt{2}) \times 38.222 = 33.689kW$. For Open-loop, RFC-A and RFC-S modes a positive value of power indicates power flowing from the drive to motor. For Regen mode a positive value of power indicates power flowing from the supply to the regen drive.

Parameter	07.034 Inverter Temperature		
Short description	Displays the estimated junction temperature of the hottest power device within the drive inverter		
Mode	Regeneration		
Minimum	-250	Maximum	250
Default		Units	°C
Type	16 Bit Volatile	Update Rate	Background write
Display Format	Standard	Decimal Places	0
Coding	RO, ND, NC, PT		

Inverter Temperature (07.034) shows the estimated junction temperature of the hottest power device within the drive inverter. If this temperature exceeds the switch down threshold defined for the power stage the switching frequency is reduced provided this feature has not been disabled (see *Auto-switching Frequency Change* (05.035)).

Parameter	07.035 Percentage Of d.c. Link Thermal Trip Level		
Short description	Displays the percentage of the maximum allowed temperature as estimated by the thermal model of the d.c. link components		
Mode	Regeneration		
Minimum	0	Maximum	100
Default		Units	%
Type	8 Bit Volatile	Update Rate	Background write
Display Format	Standard	Decimal Places	0
Coding	RO, ND, NC, PT		

Percentage Of d.c. Link Thermal Trip Level (07.035) gives the percentage of the maximum allowed temperature as estimated by the thermal model of the d.c. link components.

Parameter	07.036 Percentage Of Drive Thermal Trip Level		
Short description	Displays the percentage of the thermal trip level of the temperature monitoring point or thermal model in the drive that is highest		
Mode	Regeneration		
Minimum	0	Maximum	100
Default		Units	%
Type	8 Bit Volatile	Update Rate	Background write
Display Format	Standard	Decimal Places	0
Coding	RO, ND, NC, PT		

Percentage Of Drive Thermal Trip Level (07.036) gives the percentage of the thermal trip level of the temperature monitoring point or thermal model in the drive that is highest. This includes all thermal monitoring points (not just those selected by *Monitored Temperature 1* (07.004), *Monitored Temperature 2* (07.005) and *Monitored Temperature 3* (07.006)), *Inverter Temperature* (07.034) and *Percentage Of d.c. Link Thermal Trip Level* (07.035).

Percentage Of d.c. Link Thermal Trip Level (07.035) is used directly to give *Percentage Of Drive Thermal Trip Level* (07.036), but for all other monitored values which are temperatures this is given by Percentage of thermal trip level = (Temperature - 40°C) / (Trip temperature - 40°C) x 100%

The location of the measurement or the thermal model that is related to this temperature is given in *Temperature Nearest To Trip Level* (07.037). If *Percentage Of Drive Thermal Trip Level* (07.036) exceeds 90% *Drive Over-temperature Alarm* (10.018) is set to one. If *Percentage Of Drive Thermal Trip Level* (07.036) reaches 100% one of the trips given in the table below is initiated. The trip can be reset when the percentage of thermal trip level fall below 95%.

Temperature	Trip
<i>Inverter Temperature</i> (07.034)	OHT Inverter
Power system temperature	OHT Power
<i>Percentage Of d.c. Link Thermal Trip Level</i> (07.035)	OHT dc Link
Control system temperature	OHT Control

Parameter	07.037 Temperature Nearest To Trip Level		
Short description	Displays the thermistor location or the model that corresponds to the value shown in Percentage Of Drive Thermal Trip Level		
Mode	Regeneration		
Minimum	0	Maximum	20999
Default		Units	
Type	16 Bit Volatile	Update Rate	Background write
Display Format	Standard	Decimal Places	0
Coding	RO, ND, NC, PT		

Temperature Nearest To Trip Level (07.037) shows the thermistor location or the model that corresponds to the value shown in *Percentage Of Drive Thermal Trip Level* (07.036) in the form xxyzz as shown in the table below.

Source	xx	y	zz
Control system	00	0	01: Control board thermistor 1
Control system	00	0	02: Control board thermistor 2
Control system	00	0	03: I/O board thermistor (or internal braking resistor in servo Drive)
Control system	00	1	00: Inverter thermal model
Control system	00	2	00: D.c. link thermal model
Control system	00	3	00: Braking IGBT thermal model
Power system	01	0	zz: Thermistor location defined by zz in the power system
Power system	01	Rectifier number	zz: Thermistor location defined by zz in the rectifier

Parameter	07.038 Temperature Monitor Select 1		
Short description	Defines the temperature to be monitored in Monitored Temperature 1		
Mode	Regeneration		
Minimum	0	Maximum	1999
Default	1001	Units	
Type	16 Bit User Save	Update Rate	Background read
Display Format	Standard	Decimal Places	0
Coding	RW		

Temperature Monitor Select 1 (07.038) selects the temperature to be monitored in *Monitored Temperature 1* (07.004) using the format given for *Temperature Nearest To Trip Level* (07.037). If the monitoring point selected does not exist then the monitored temperature is always zero. The table below shows the monitoring points that can be selected.

Source	xx	y	zz
Control system	00	0	01: Control board thermistor 1
Control system	00	0	02: Control board thermistor 2
Control system	00	0	03: I/O board thermistor (or internal braking resistor in Servo Drive)
Control system	00	1	00: Inverter thermal model
Control system	00	3	00: Braking IGBT thermal model
Control system	00	4	00: Rectifier thermal model
Power system	01	0	zz: Thermistor location defined by zz in the power system
Power system	01	Rectifier number	zz: Thermistor location defined by zz in the rectifier

For a multi-module power system the power system measurement that can be selected is shown in the table below. It should be noted that the specific power module cannot be selected and that the highest temperature from each of the power modules is given.

Source	xx	y	zz
Power system	01	0	01: U phase power device thermistor
Power system	01	0	02: V phase power device thermistor
Power system	01	0	03: W phase power device thermistor
Power system	01	0	04: General rectifier thermistors
Power system	01	0	05: General power system thermistor

Parameter	07.039 Temperature Monitor Select 2		
Short description	Defines the temperature to be monitored in Monitored Temperature 2		
Mode	Regeneration		
Minimum	0	Maximum	1999
Default	1002	Units	
Type	16 Bit User Save	Update Rate	Background read
Display Format	Standard	Decimal Places	0
Coding	RW		

See *Temperature Monitor Select 1* (07.038).

Parameter	07.040 Analog Input 1 Minimum		
Short description	Defines the minimum value for analog input 1		
Mode	Regeneration		
Minimum	-100.00	Maximum	100.00
Default	-100.00	Units	%
Type	16 Bit User Save	Update Rate	Background read
Display Format	Standard	Decimal Places	2
Coding	RW		

See *Analog Input 1* (07.001).

Parameter	07.043 Analog Input 1 Maximum		
Short description	Defines the maximum value for analog input 1		
Mode	Regeneration		
Minimum	-100.00	Maximum	100.00
Default	100.00	Units	%
Type	16 Bit User Save	Update Rate	Background read
Display Format	Standard	Decimal Places	2
Coding	RW		

See *Analog Input 1* (07.001).

Parameter	07.051 Analog Input 1 Full Scale		
Short description	Displays the full scale value of analog input 1		
Mode	Regeneration		
Minimum	0	Maximum	65535
Default		Units	
Type	16 Bit Power Down Save	Update Rate	Background write
Display Format	Standard	Decimal Places	0
Coding	RO, ND, NC, PT, BU		

See *Calibrate Analog Input 1 Full Scale* (07.025).

Parameter	07.052 <i>Temperature Monitor Select 3</i>		
Short description	Defines the temperature to be monitored in Monitored Temperature 3		
Mode	Regeneration		
Minimum	0	Maximum	1999
Default	1	Units	
Type	16 Bit User Save	Update Rate	Background read
Display Format	Standard	Decimal Places	0
Coding	RW		

See *Temperature Monitor Select 1* (07.038).

Menu 8 Single Line Descriptions – Regen Digital I/O

Mode: Regeneration

Parameter		Range	Default	Type					
08.001	Digital Output 01 State	Off (0) or On (1)		RO	Bit	ND	NC	PT	
08.002	Digital Output 02 State	Off (0) or On (1)		RO	Bit	ND	NC	PT	
08.004	Digital Input 04 State	Off (0) or On (1)		RO	Bit	ND	NC	PT	
08.005	Digital Input 05 State	Off (0) or On (1)		RO	Bit	ND	NC	PT	
08.008	24V Supply Output State	Off (0) or On (1)		RO	Bit	ND	NC	PT	
08.009	STO Input 01 State	Off (0) or On (1)		RO	Bit	ND	NC	PT	
08.010	External Trip Mode	Disable (0), STO 1 (1), STO 2 (2), STO 1 OR STO 2 (3)	Disable (0)	RW	Txt				US
08.011	Digital Output 01 Invert	Not Invert (0), Invert (1)	Not Invert (0)	RW	Txt				US
08.012	Digital Output 02 Invert	Not Invert (0), Invert (1)	Not Invert (0)	RW	Txt				US
08.014	Digital Input 04 Invert	Not Invert (0), Invert (1)	Not Invert (0)	RW	Txt				US
08.015	Digital Input 05 Invert	Not Invert (0), Invert (1)	Not Invert (0)	RW	Txt				US
08.018	24V Supply Output Invert	Not Invert (0), Invert (1)	Invert (1)	RW	Txt				US
08.020	Digital I/O Read Word	0 to 511		RO	Num	ND	NC	PT	
08.021	Digital Output 01 Source	0.000 to 59.999	3.009	RW	Num	DE		PT	US
08.022	Digital Output 02 Source	0.000 to 59.999	3.007	RW	Num	DE		PT	US
08.024	Digital Input 04 Destination	0.000 to 59.999	10.033	RW	Num	DE		PT	US
08.025	Digital Input 05 Destination	0.000 to 59.999	3.008	RW	Num	DE		PT	US
08.028	24V Supply Output Source	0.000 to 59.999	0.000	RW	Num			PT	US
08.040	STO Input 02 State	Off (0) or On (1)		RO	Bit	ND	NC	PT	
08.041	Keypad Run Button State	Off (0) or On (1)		RO	Bit	ND	NC	PT	
08.042	Keypad Auxiliary Button State	Off (0) or On (1)		RO	Bit	ND	NC	PT	
08.044	Keypad Stop Button State	Off (0) or On (1)		RO	Bit	ND	NC	PT	
08.046	Drive Reset Button State	Off (0) or On (1)		RO	Bit	ND	NC	PT	
08.051	Keypad Run Button Invert/Toggle	Not Invert (0), Invert (1), Toggle (2)	Not Invert (0)	RW	Txt				US
08.052	Keypad Auxiliary Button Invert/Toggle	Not Invert (0), Invert (1), Toggle (2)	Not Invert (0)	RW	Txt				US
08.061	Keypad Run Button Destination	0.000 to 59.999	0.000	RW	Num	DE		PT	US
08.062	Keypad Auxiliary Button Destination	0.000 to 59.999	0.000	RW	Num	DE		PT	US
08.071	Digital I/O Output Enable Register 1	0000000000000000 to 1111111111111111	0000000000000000	RW	Bin			PT	US
08.072	Digital I/O Input Register 1	0000000000000000 to 1111111111111111	0000000000000000	RO	Bin			PT	
08.073	Digital I/O Output Register 1	0000000000000000 to 1111111111111111	0000000000000000	RW	Bin			PT	

RW	Read / Write	RO	Read-only	Bit	Bit parameter	Txt	Text string	Date	Date parameter	Time	Time parameter
Chr	Character parameter	Bin	Binary parameter	IP	IP address	Mac	MAC address	Ver	Version number	SMP	Slot, menu, parameter
Num	Number parameter	DE	Destination	ND	No default value	RA	Rating dependent	NC	Non-copyable	PT	Protected
Fl	Filtered	US	User save	PS	Power-down save						

Menu 8 – Regen Digital I/O

Mode: Regeneration

Digital I/O Interface

The normal sample rate for the digital I/O system is 2ms, however it is possible to obtain a faster update rate for some parameters with certain inputs as described below. (Note that the keypad buttons are always updated at the background rate and cannot be used for fast updating.)

Direction, read and write register parameters

Digital I/O Output Enable Register 1 (08.071), Digital I/O Input Register 1 (08.072) and Digital I/O Output Register 1 (08.073) provide direct access to read/control the digital I/O that is integral to the drive.

Parameters

The same parameter structure is used for every digital I/O except for safe torque off inputs which are dedicated inputs that do not include routing as shown in the diagram below.

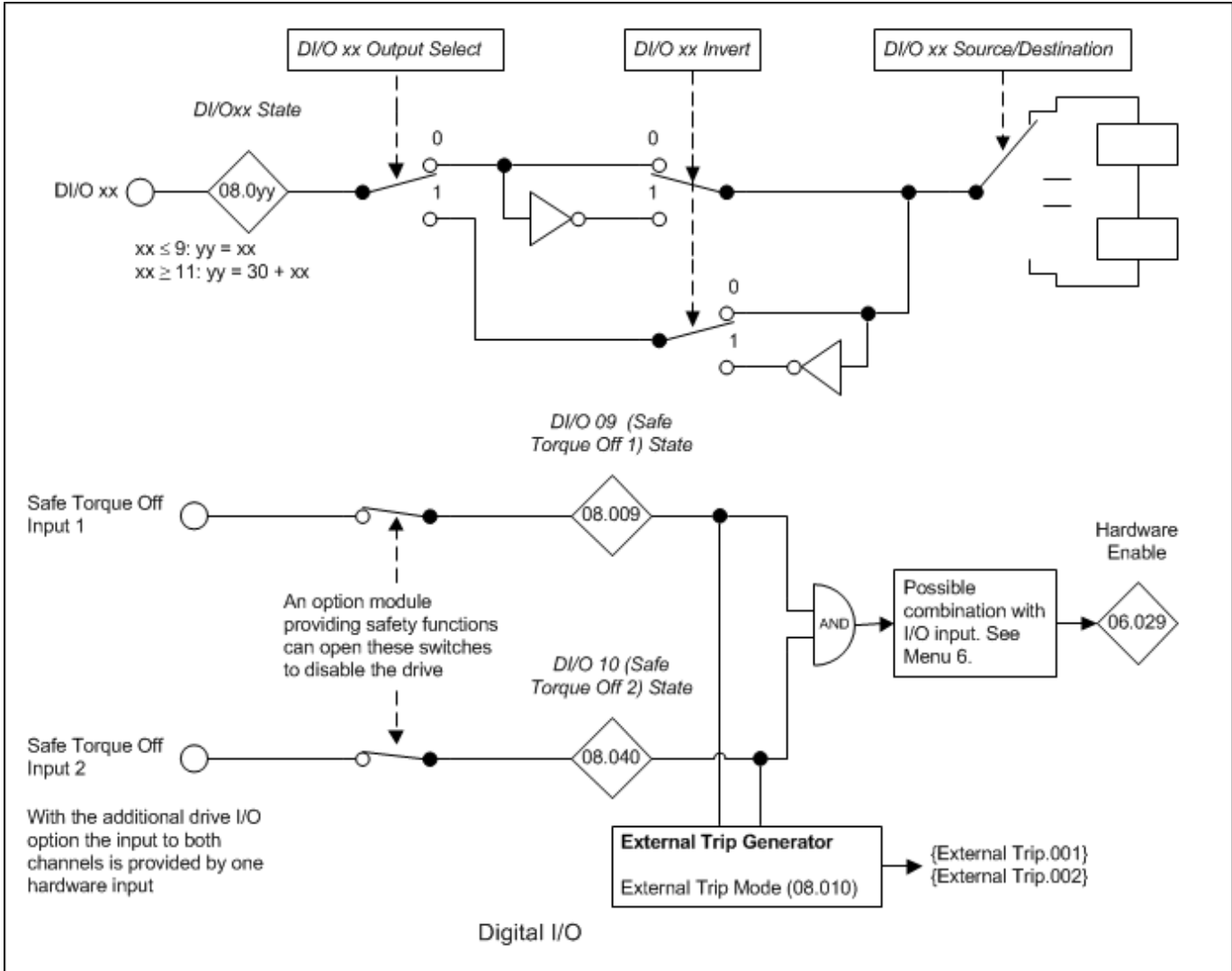

The table below gives the digital I/O parameter structure. The non-shaded parameters are available with the basic drive I/O (*Internal I/O Identifier* (11.068) = 0) and the shaded parameters are also present with additional drive I/O (*ParameterCaption*(Number) *InternalIdentifier* = 1).

DI/O	Function	State	Invert/Toggle	Source/Destination	Output Select
1	Input/Output	08.001	08.011	08.021	08.031*
2	Input/Output	08.002	08.012	08.022	08.032*
3	Input/Output	08.003	08.013	08.023	08.033*
4	Input	08.004	08.014	08.024	
5	Input	08.005	08.015	08.025	
6	Input	08.006	08.016	08.026	
7	Relay Output	08.007	08.017	08.027	
8	24V Supply Output	08.008	08.018	08.028	
9	Safe Torque Off 1	08.009			
10	Safe Torque Off 2	08.040			
11	Keypad Run Button	08.041	08.051	08.061	
12	Keypad Auxiliary Button	08.042	08.052	08.062	
13	24V Supply Input	08.043	08.053	08.063	

*Forced to 1 with basic drive I/O, because the default is 1 and the parameter is not visible.

Parameter	08.001 Digital Output 01 State		
Short description	Displays the state for digital output 1		
Mode	Regeneration		
Minimum	0	Maximum	1
Default		Units	
Type	1 Bit Volatile	Update Rate	2ms write
Display Format	Standard	Decimal Places	0
Coding	RO, ND, NC, PT		

The Digital I/O State parameter shows the state of digital I/O on the drive. All I/O except Digital Input 11 (Keypad Run Button), Digital Input 12 (Keypad Auxiliary Button), Digital Input 13 (24V Supply Input) and Digital Input 14 (Keypad Stop Button) use IEC61131-2 logic levels. As default the inputs use positive logic, and so the state parameter is 0 if the digital I/O is low or 1 if the digital I/O is high. *Input Logic Polarity* (08.029) can be set to zero to change the logic for Digital I/O1-6 to negative logic, so that the state parameter is 0 if the digital I/O is high or 1 if the digital I/O is low. The state parameter represents the digital I/O state whether it is an input or an output. If the digital I/O is configured as an output to be controlled using the *Digital I/O Output Register 1* (08.073) then the state parameter will still show the state of the output even though the route source is zero and the invert parameter has no effect.

Digital Input 11 (Keypad Run Button), Digital Input 12 (Keypad Auxiliary Button) and Digital Input 14 (Keypad Stop Button) represent the state of the Run, Auxiliary and Stop buttons on any keypad fitted to the drive; the input state is determined by ORing the state of the button on each keypad connected to the drive, if the button is pressed the state parameter is one otherwise it is zero. If a keypad is not fitted the state parameters are zero.

Digital Input 13 (24V Supply Input) is an external 24V supply input that is monitored and can be used as a 24V digital input if an external 24V supply is not required. The state parameter is low for the voltage range from 0V to 17V and high for the voltage range above 18V. As the input is a power supply it will consume significant current if the level is taken above 24V when the drive is running from its internal power supply, or at any voltage level if this input is the only power supply to the drive.

Digital Input 09 (STO input 1) and Digital Input 10 (STO input 2) correspond to two safe torque off channels within the drive. Both channels must be in the high state for the drive to be enabled. The state parameters are 0 if the digital input is low, or 1 if the digital input is high. If option slot 3 does not contain an option module providing safety functions then both safe torque off channels are connected to their state parameters and the safe torque off input can enable/disable the drive. If an option module providing safety functions is fitted in option slot 3 then the option module can disable the drive by breaking the path of either one or both safe torque off channels. See Menu 6 for details of the drive enable system.

Parameter	08.002 Digital Output 02 State		
Short description	Displays the state for digital output 2		
Mode	Regeneration		
Minimum	0	Maximum	1
Default		Units	
Type	1 Bit Volatile	Update Rate	2ms write
Display Format	Standard	Decimal Places	0
Coding	RO, ND, NC, PT		

See *Digital Output 01 State* (08.001).

Parameter	08.004 Digital Input 04 State		
Short description	Displays the state for digital input 4		
Mode	Regeneration		
Minimum	0	Maximum	1
Default		Units	
Type	1 Bit Volatile	Update Rate	2ms write
Display Format	Standard	Decimal Places	0
Coding	RO, ND, NC, PT		

See *Digital Output 01 State* (08.001).

Parameter	08.005 Digital Input 05 State		
Short description	Displays the state for digital input 5		
Mode	Regeneration		
Minimum	0	Maximum	1
Default		Units	
Type	1 Bit Volatile	Update Rate	2ms write
Display Format	Standard	Decimal Places	0
Coding	RO, ND, NC, PT		

See *Digital Output 01 State* (08.001).

Parameter	08.008 24V Supply Output State		
Short description	Displays the state for 24V supply output		
Mode	Regeneration		
Minimum	0	Maximum	1
Default		Units	
Type	1 Bit Volatile	Update Rate	2ms write
Display Format	Standard	Decimal Places	0
Coding	RO, ND, NC, PT		

See *Digital Output 01 State* (08.001).

Parameter	08.009 STO Input 01 State		
Short description	Displays the state for Safe Torque Off 1 input		
Mode	Regeneration		
Minimum	0	Maximum	1
Default		Units	
Type	1 Bit Volatile	Update Rate	2ms write
Display Format	Standard	Decimal Places	0
Coding	RO, ND, NC, PT		

See *Digital Output 01 State* (08.001).

Parameter	08.010 External Trip Mode		
Short description	Defines behaviour of drive if STOs are low		
Mode	Regeneration		
Minimum	0	Maximum	3
Default	0	Units	
Type	8 Bit User Save	Update Rate	Background read
Display Format	Standard	Decimal Places	0
Coding	RW, TE		

Value	Text
0	Disable
1	STO 1
2	STO 2
3	STO 1 OR STO 2

If *External Trip Mode* (08.010) = 0 the safe torque off inputs simply enable or disable the drive. If *External Trip Mode* (08.010) > 0 it is possible to enable the following trip functions.

External Trip Mode (08.010)	Actions
0	Safe torque off inputs do not initiate trips
1	<i>External Trip.001</i> if Safe Torque Off Input 1 is low
2	<i>External Trip.002</i> if Safe Torque Off Input 2 is low
3	<i>External Trip.001</i> if Safe Torque Off is low OR <i>External Trip.002</i> if Safe Torque Off Input 2 is low

Parameter	08.011 Digital Output 01 Invert		
Short description	Set to invert Digital Output 01		
Mode	Regeneration		
Minimum	0	Maximum	1
Default	0	Units	
Type	8 Bit User Save	Update Rate	Background read
Display Format	Standard	Decimal Places	0
Coding	RW, TE		

Value	Text
0	Not Invert
1	Invert

A value of 0 or 1 allows the digital I/O to be non-inverted or inverted respectively.

Parameter	08.012 Digital Output 02 Invert		
Short description	Set to invert Digital Output 02		
Mode	Regeneration		
Minimum	0	Maximum	1
Default	0	Units	
Type	8 Bit User Save	Update Rate	Background read
Display Format	Standard	Decimal Places	0
Coding	RW, TE		

Value	Text
0	Not Invert
1	Invert

See *Digital Output 01 Invert* (08.011).

Parameter	08.014 Digital Input 04 Invert		
Short description	Set to invert Digital Input 04		
Mode	Regeneration		
Minimum	0	Maximum	1
Default	0	Units	
Type	8 Bit User Save	Update Rate	Background read
Display Format	Standard	Decimal Places	0
Coding	RW, TE		

Value	Text
0	Not Invert
1	Invert

See *Digital Output 01 Invert* (08.011).

Parameter	08.015 Digital Input 05 Invert		
Short description	Set to invert Digital Input 05		
Mode	Regeneration		
Minimum	0	Maximum	1
Default	0	Units	
Type	8 Bit User Save	Update Rate	Background read
Display Format	Standard	Decimal Places	0
Coding	RW, TE		

Value	Text
0	Not Invert
1	Invert

See *Digital Output 01 Invert* (08.011).

Parameter	08.018 24V Supply Output Invert		
Short description	Set to invert 24V Supply Output		
Mode	Regeneration		
Minimum	0	Maximum	1
Default	1	Units	
Type	8 Bit User Save	Update Rate	Background read
Display Format	Standard	Decimal Places	0
Coding	RW, TE		

Value	Text
0	Not Invert
1	Invert

See *Digital Output 01 Invert* (08.011).

Parameter	08.020 Digital I/O Read Word		
Short description	Displays the states for digital I/O 1 to 8		
Mode	Regeneration		
Minimum	0	Maximum	511
Default		Units	
Type	16 Bit Volatile	Update Rate	Background write
Display Format	Standard	Decimal Places	0
Coding	RO, ND, NC, PT		

Digital I/O Read Word (08.020) reflects the state of digital input/output 1 to STO input 1 as given below. Each bit matches the value of the state parameter for the respective digital input or output.

Digital I/O Read Word (08.020) bit	Digital I/O
0	Digital I/O 1
1	Digital I/O 2
2	Digital I/O 3
3	Digital Input 4
4	Digital Input 5
5	Digital Input 6
6	Relay
7	24V Output
8	STO Input 1

Parameter	08.021 Digital Output 01 Source		
Short description	Defines the source parameter for Digital Output 1		
Mode	Regeneration		
Minimum	0.000	Maximum	59.999
Default	3.009	Units	
Type	16 Bit User Save	Update Rate	Drive Reset Read
Display Format	Standard	Decimal Places	3
Coding	RW, DE, PT, BU		

The Digital I/O Source/Destination parameters provide the routing for the source and/or destination for the digital I/O.

Parameter	08.022 Digital Output 02 Source		
Short description	Defines the source parameter for Digital Output 2		
Mode	Regeneration		
Minimum	0.000	Maximum	59.999
Default	3.007	Units	
Type	16 Bit User Save	Update Rate	Drive Reset Read
Display Format	Standard	Decimal Places	3
Coding	RW, DE, PT, BU		

See *Digital Output 01 Source* (08.021).

Parameter	08.024 Digital Input 04 Destination		
Short description	Defines the destination parameter for Digital Input 4		
Mode	Regeneration		
Minimum	0.000	Maximum	59.999
Default	10.033	Units	
Type	16 Bit User Save	Update Rate	Drive Reset Read
Display Format	Standard	Decimal Places	3
Coding	RW, DE, PT, BU		

See *Digital Output 01 Source* (08.021).

Parameter	08.025 Digital Input 05 Destination		
Short description	Defines the destination parameter for Digital Input 5		
Mode	Regeneration		
Minimum	0.000	Maximum	59.999
Default	3.008	Units	
Type	16 Bit User Save	Update Rate	Drive Reset Read
Display Format	Standard	Decimal Places	3
Coding	RW, DE, PT, BU		

See *Digital Output 01 Source* (08.021).

Parameter	08.028 24V Supply Output Source		
Short description	Defines the source parameter for 24V Supply Output		
Mode	Regeneration		
Minimum	0.000	Maximum	59.999
Default	0.000	Units	
Type	16 Bit User Save	Update Rate	Drive Reset Read
Display Format	Standard	Decimal Places	3
Coding	RW, PT, BU		

See *Digital Output 01 Source* (08.021).

Parameter	08.040 STO Input 02 State		
Short description	Displays the state for the Safe Torque Off 2 input		
Mode	Regeneration		
Minimum	0	Maximum	1
Default		Units	
Type	1 Bit Volatile	Update Rate	2ms write
Display Format	Standard	Decimal Places	0
Coding	RO, ND, NC, PT		

See *Digital Output 01 State* (08.001).

Parameter	08.041 Keypad Run Button State		
Short description	Displays the state for the Keypad Run Forward button		
Mode	Regeneration		
Minimum	0	Maximum	1
Default		Units	
Type	1 Bit Volatile	Update Rate	Background write
Display Format	Standard	Decimal Places	0
Coding	RO, ND, NC, PT		

See *Digital Output 01 State* (08.001).

Parameter	08.042 Keypad Auxiliary Button State		
Short description	Displays the state for the Keypad Auxiliary button		
Mode	Regeneration		
Minimum	0	Maximum	1
Default		Units	
Type	1 Bit Volatile	Update Rate	Background write
Display Format	Standard	Decimal Places	0
Coding	RO, ND, NC, PT		

See *Digital Output 01 State* (08.001).

Parameter	08.044 Keypad Stop Button State		
Short description	Displays the state for the Keypad Stop button		
Mode	Regeneration		
Minimum	0	Maximum	1
Default		Units	
Type	1 Bit Volatile	Update Rate	Background write
Display Format	Standard	Decimal Places	0
Coding	RO, ND, NC, PT		

See *Digital Output 01 State* (08.001).

Parameter	08.046 Drive Reset Button State		
Short description	Displays the state of the reset button on the front of the drive		
Mode	Regeneration		
Minimum	0	Maximum	0
Default		Units	
Type	1 Bit Volatile	Update Rate	Background write
Display Format	Standard	Decimal Places	0
Coding	RO, ND, NC, NV, PT		

See *Digital Output 01 State* (08.001).

Parameter	08.051 Keypad Run Button Invert/Toggle		
Short description	Set to invert/toggle Keypad Run Button		
Mode	Regeneration		
Minimum	0	Maximum	2
Default	0	Units	
Type	8 Bit User Save	Update Rate	Background Read
Display Format	Standard	Decimal Places	0
Coding	RW, TE		

Value	Text
0	Not Invert
1	Invert
2	Toggle

A value of 0 or 1 allows the input state to be non-inverted or inverted respectively. An additional toggle function is provided for Keypad Run button inputs. The toggle function output changes state on each rising edge (0 to 1 change) at its input.

Parameter	08.052 Keypad Auxiliary Button Invert/Toggle		
Short description	Set to invert/toggle Keypad Auxiliary Button		
Mode	Regeneration		
Minimum	0	Maximum	2
Default	0	Units	
Type	8 Bit User Save	Update Rate	Background Read
Display Format	Standard	Decimal Places	0
Coding	RW, TE		

Value	Text
0	Not Invert
1	Invert
2	Toggle

A value of 0 or 1 allows the input state to be non-inverted or inverted respectively. An additional toggle function is provided for Keypad Auxiliary button inputs. The toggle function output changes state on each rising edge (0 to 1 change) at its input.

Parameter	08.061 Keypad Run Button Destination		
Short description	Defines the destination parameter for the keypad run button		
Mode	Regeneration		
Minimum	0.000	Maximum	59.999
Default	0.000	Units	
Type	16 Bit User Save	Update Rate	Drive Reset Read
Display Format	Standard	Decimal Places	3
Coding	RW, DE, PT, BU		

See *Digital Output 01 Source* (08.021).

Parameter	08.062 Keypad Auxiliary Button Destination		
Short description	Defines the destination parameter for the keypad auxiliary button		
Mode	Regeneration		
Minimum	0.000	Maximum	59.999
Default	0.000	Units	
Type	16 Bit User Save	Update Rate	Drive Reset Read
Display Format	Standard	Decimal Places	3
Coding	RW, DE, PT, BU		

See *Digital Output 01 Source* (08.021).

Parameter	08.071 Digital I/O Output Enable Register 1		
Short description	Displays the binary form of the DI/O output enable register		
Mode	Regeneration		
Minimum	0 (Display: 0000000000000000)	Maximum	65535 (Display: 1111111111111111)
Default	0 (Display: 0000000000000000)	Units	
Type	16 Bit User Save	Update Rate	Background read
Display Format	Binary	Decimal Places	0
Coding	RW, PT, BU		

The bits in the *Digital I/O Output Enable Register 1* (08.071), *Digital I/O Input Register 1* (08.072) and *Digital I/O Output Register 1* (08.073) each correspond with one digital I/O as shown below. The update rate of the individual bits in these registers differs depending upon the I/O.

DI/O	Bit	Function	Bit update rate		
			Input Register	Output Register	Output Enable Register
1	0	Digital Input/Output	2ms	250µs	Background
2	1	Digital Input/Output	2ms	250µs	Background
3	2	Digital Input/Output	2ms	2ms	Background
4	3	Digital Input	250µs	Not applicable	Not applicable
5	4	Digital Input	250µs	Not applicable	Not applicable
6	5	Digital Input	2ms	Not applicable	Not applicable
7	6	Relay Output	Bit always 0	2ms	Background
8	7	24V Supply Output	Bit always 0	2ms	Background
9	8	Safe Torque Off 1	2ms	Not applicable	Not applicable
10	9	Safe Torque Off 2	2ms	Not applicable	Not applicable
11	10	Keypad Run Button	Background	Not applicable	Not applicable
12	11	Keypad Auxiliary Button	Background	Not applicable	Not applicable
13	12	24V Supply Input	2ms	Not applicable	Not applicable
14	13	Keypad Stop Button	Background	Not applicable	Not applicable
15	14	Relay 2 Output	Bit always 0	2ms	Background
16	15	Drive Reset Button	Background	Not applicable	Not applicable

The *Digital I/O Input Register 1* (08.072) is always active and shows the value in the Digital I/O State parameter for all digital I/O configured as inputs. Bits in the *Digital I/O Output Register 1* (08.073) can be used to control the digital I/O directly. The bits control the output directly and are not modified by the corresponding Digital I/O Invert/Toggle function. The bits in the *Digital I/O Output Register 1* (08.073) only control the corresponding digital output if all the conditions below are met:

1. The corresponding bit in the *Digital I/O Output Enable Register 1* (08.071) must be set to 1.
2. The digital I/O must be an output, or it must be an input/output and the corresponding Digital I/O Output Select parameter must be one.
3. The corresponding Digital I/O Source/Destination parameter is not as valid source (e.g. 0.000) and the drive has been powered-up or reset since it was first selected.

If the above conditions are not met, the digital output is controlled by the normal logic.

Parameter	08.072 Digital I/O Input Register 1		
Short description	Displays the binary form of the DI/O input register		
Mode	Regeneration		
Minimum	0 (Display: 0000000000000000)	Maximum	65535 (Display: 1111111111111111)
Default	0 (Display: 0000000000000000)	Units	
Type	16 Bit Volatile	Update Rate	250µs write
Display Format	Binary	Decimal Places	0
Coding	RO, PT, BU		

See *Digital I/O Output Enable Register 1* (08.071).

Parameter	08.073 Digital I/O Output Register 1		
Short description	Displays the binary form of the DI/O output register		
Mode	Regeneration		
Minimum	0 (Display: 0000000000000000)	Maximum	65535 (Display: 1111111111111111)
Default	0 (Display: 0000000000000000)	Units	
Type	16 Bit Volatile	Update Rate	250µs read
Display Format	Binary	Decimal Places	0
Coding	RW, PT, BU		

See *Digital I/O Output Enable Register 1* (08.071).

Menu 9 Single Line Descriptions – *User Functions 1*

Mode: Regeneration

Parameter	Range	Default	Type						
			RO	Bit	ND	NC	PT		
09.001	Logic Function 1 Output	Off (0) or On (1)		RO	Bit	ND	NC	PT	
09.002	Logic Function 2 Output	Off (0) or On (1)		RO	Bit	ND	NC	PT	
09.003	Motorised Pot Output	±100.00 %		RO	Num	ND	NC	PT	PS
09.004	Logic Function 1 Source 1	0.000 to 59.999	0.000	RW	Num			PT	US
09.005	Logic Function 1 Source 1 Invert	Off (0) or On (1)	Off (0)	RW	Bit				US
09.006	Logic Function 1 Source 2	0.000 to 59.999	0.000	RW	Num			PT	US
09.007	Logic Function 1 Source 2 Invert	Off (0) or On (1)	Off (0)	RW	Bit				US
09.008	Logic Function 1 Output Invert	Off (0) or On (1)	Off (0)	RW	Bit				US
09.009	Logic Function 1 Delay	±25.0 s	0.0 s	RW	Num				US
09.010	Logic Function 1 Destination	0.000 to 59.999	0.000	RW	Num	DE		PT	US
09.014	Logic Function 2 Source 1	0.000 to 59.999	0.000	RW	Num			PT	US
09.015	Logic Function 2 Source 1 Invert	Off (0) or On (1)	Off (0)	RW	Bit				US
09.016	Logic Function 2 Source 2	0.000 to 59.999	0.000	RW	Num			PT	US
09.017	Logic Function 2 Source 2 Invert	Off (0) or On (1)	Off (0)	RW	Bit				US
09.018	Logic Function 2 Output Invert	Off (0) or On (1)	Off (0)	RW	Bit				US
09.019	Logic Function 2 Delay	±25.0 s	0.0 s	RW	Num				US
09.020	Logic Function 2 Destination	0.000 to 59.999	0.000	RW	Num	DE		PT	US
09.021	Motorised Pot Mode	0 to 4	0	RW	Num				US
09.022	Motorised Pot Bipolar Select	Off (0) or On (1)	Off (0)	RW	Bit				US
09.023	Motorised Pot Rate	0 to 250 s	20 s	RW	Num				US
09.024	Motorised Pot Scaling	0.000 to 4.000	1.000	RW	Num				US
09.025	Motorised Pot Destination	0.000 to 59.999	0.000	RW	Num	DE		PT	US
09.026	Motorised Pot Up	Off (0) or On (1)	Off (0)	RW	Bit		NC		
09.027	Motorised Pot Down	Off (0) or On (1)	Off (0)	RW	Bit		NC		
09.028	Motorised Pot Reset	Off (0) or On (1)	Off (0)	RW	Bit		NC		
09.029	Binary Sum Ones	Off (0) or On (1)	Off (0)	RW	Bit		NC		
09.030	Binary Sum Twos	Off (0) or On (1)	Off (0)	RW	Bit		NC		
09.031	Binary Sum Fours	Off (0) or On (1)	Off (0)	RW	Bit		NC		
09.032	Binary Sum Output	0 to 255		RO	Num	ND	NC	PT	
09.033	Binary Sum Destination	0.000 to 59.999	0.000	RW	Num	DE		PT	US
09.034	Binary Sum Offset	0 to 248	0	RW	Num				US
09.035	Timer 1 Start Date	00-00-00 to 31-12-99	00-00-00	RW	Date				US
09.036	Timer 1 Start Time	00:00:00 to 23:59:59	00:00:00	RW	Time				US
09.037	Timer 1 Stop Date	00-00-00 to 31-12-99	00-00-00	RW	Date				US
09.038	Timer 1 Stop Time	00:00:00 to 23:59:59	00:00:00	RW	Time				US
09.039	Timer 1 Repeat Function	None (0), Hour (1), Day (2), Week (3), Month (4), Year (5), One off (6), Minute (7)	None (0)	RW	Txt				US
09.040	Timer 1 Enable	Off (0) or On (1)	Off (0)	RW	Bit				US
09.041	Timer 1 Invert	Off (0) or On (1)	Off (0)	RW	Bit				US
09.042	Timer 1 Output	Off (0) or On (1)		RO	Bit	ND	NC	PT	
09.043	Timer 1 Destination	0.000 to 59.999	0.000	RW	Num	DE		PT	US
09.045	Timer 2 Start Date	00-00-00 to 31-12-99	00-00-00	RW	Date				US
09.046	Timer 2 Start Time	00:00:00 to 23:59:59	00:00:00	RW	Time				US
09.047	Timer 2 Stop Date	00-00-00 to 31-12-99	00-00-00	RW	Date				US
09.048	Timer 2 Stop Time	00:00:00 to 23:59:59	00:00:00	RW	Time				US
09.049	Timer 2 Repeat Function	None (0), Hour (1), Day (2), Week (3), Month (4), Year (5), One off (6), Minute (7)	None (0)	RW	Txt				US
09.050	Timer 2 Enable	Off (0) or On (1)	Off (0)	RW	Bit				US
09.051	Timer 2 Invert	Off (0) or On (1)	Off (0)	RW	Bit				US
09.052	Timer 2 Output	Off (0) or On (1)		RO	Bit	ND	NC	PT	
09.053	Timer 2 Destination	0.000 to 59.999	0.000	RW	Num	DE		PT	US
09.055	Scope Trace 1 Source	0.000 to 59.999	0.000	RW	Num			PT	US
09.056	Scope Trace 2 Source	0.000 to 59.999	0.000	RW	Num			PT	US
09.057	Scope Trace 3 Source	0.000 to 59.999	0.000	RW	Num			PT	US
09.058	Scope Trace 4 Source	0.000 to 59.999	0.000	RW	Num			PT	US
09.059	Scope Trigger	Off (0) or On (1)	Off (0)	RW	Bit				
09.060	Scope Trigger Source	0.000 to 59.999	10.001	RW	Num			PT	US
09.061	Scope Trigger Threshold	-2147483648 to 2147483647	0	RW	Num				US
09.062	Scope Trigger Invert	Off (0) or On (1)	On (1)	RW	Bit				US
09.063	Scope Mode	Single (0), Normal (1), Auto (2)	Normal (1)	RW	Txt				US
09.064	Scope Arm	Off (0) or On (1)	Off (0)	RW	Bit		NC		
09.065	Scope Data Not Ready	Off (0) or On (1)		RO	Bit	ND	NC	PT	

09.066	Scope Saving Data	Off (0) or On (1)		RO	Bit	ND	NC	PT	
09.067	Scope Sample Time	1 to 200	4	RW	Num				US
09.068	Scope Trigger Delay	0 to 100 %	100 %	RW	Num				US
09.069	Scope Time Period	0.00 to 200000.00 ms		RO	Num	ND	NC	PT	
09.070	Scope Auto-save Mode	Disabled (0), Overwrite (1), Keep (2)	Disabled (0)	RW	Txt				US
09.071	Scope Auto-save File Number	0 to 99	0	RO	Num		NC		PS
09.072	Scope Auto-save Reset	Off (0) or On (1)	Off (0)	RW	Bit				
09.073	Scope Auto-save Status	Disabled (0), Active (1), Stopped (2), Failed (3)	Disabled (0)	RO	Txt		NC		PS

RW	Read / Write	RO	Read-only	Bit	Bit parameter	Txt	Text string	Date	Date parameter	Time	Time parameter
Chr	Character parameter	Bin	Binary parameter	IP	IP address	Mac	MAC address	Ver	Version number	SMP	Slot, menu, parameter
Num	Number parameter	DE	Destination	ND	No default value	RA	Rating dependent	NC	Non-copyable	PT	Protected
FI	Filtered	US	User save	PS	Power-down save						

Menu 9 – *User Functions 1*

Mode: Regeneration

Menu 9 provides the parameters for the following features:

1. Logic functions
2. Motorised Pot
3. Binary Sum
4. Timers
5. Scope function

Logic functions

The logic functions are always active even if the sources and destinations are not routed to valid parameters. If the sources are not valid parameters then the source values are taken as 0. The update rate for each of the logic functions is always 4ms.

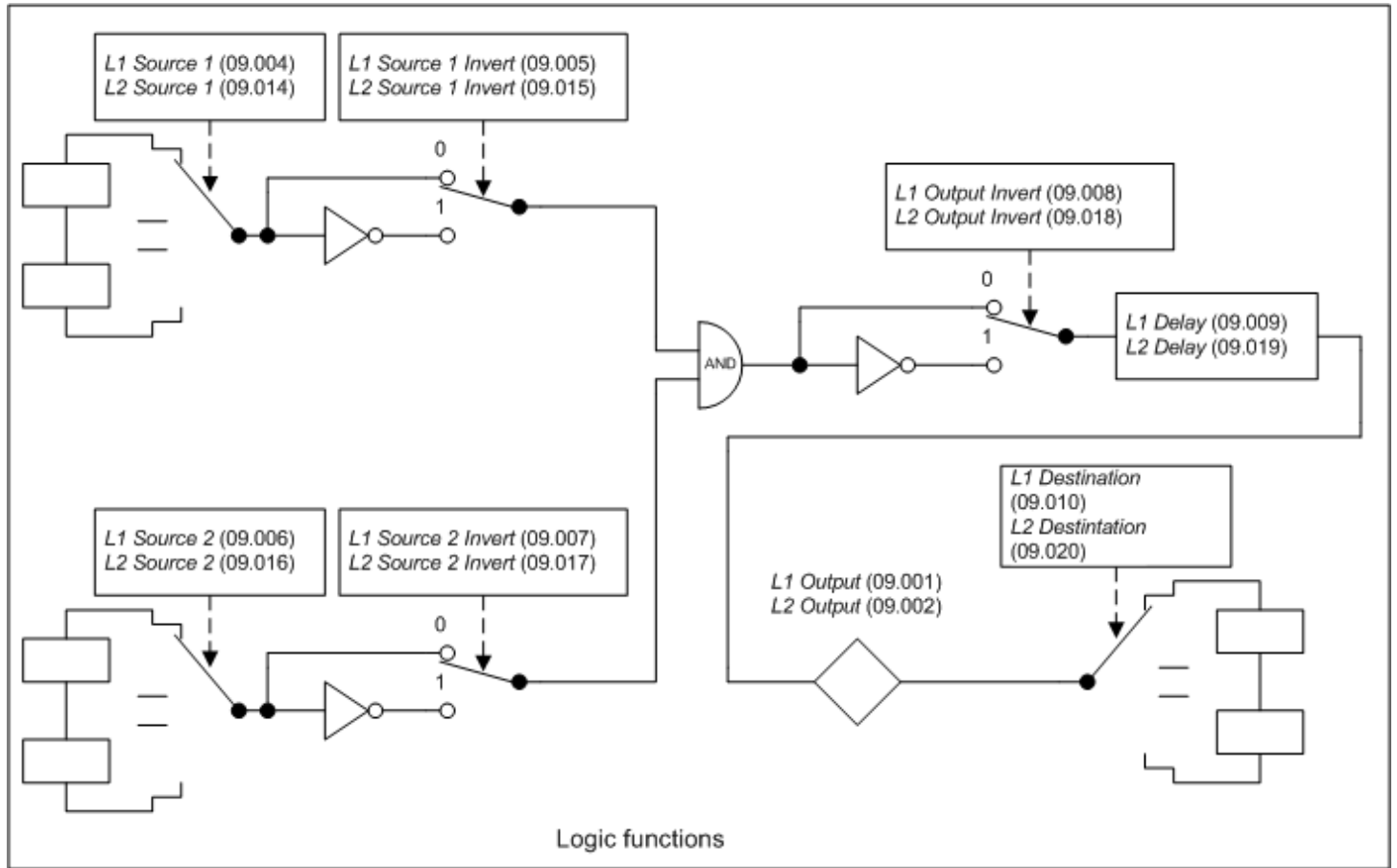

The logic function consists of an AND gate with inverters on each input and an inverter on the output. Some of the other standard logic functions can be produced as shown in the table below.

Logic function	Source 1 Invert	Source 2 Invert	Output Invert
AND	0	0	0
NAND	0	0	1
OR	1	1	1
NOR	1	1	0

A delay function is provided at the output of the logic functions. If *Logic Function 1 Delay* (09.009) or *Logic Function 2 Delay* (09.019) is positive then the output does not become 1 until the input to the delay has been at 1 for the delay time. If *Logic Function 1 Delay* (09.009) or *Logic Function 2 Delay* (09.019) is negative then the output remains at 1 until the input to the delay has been 0 for the delay time.

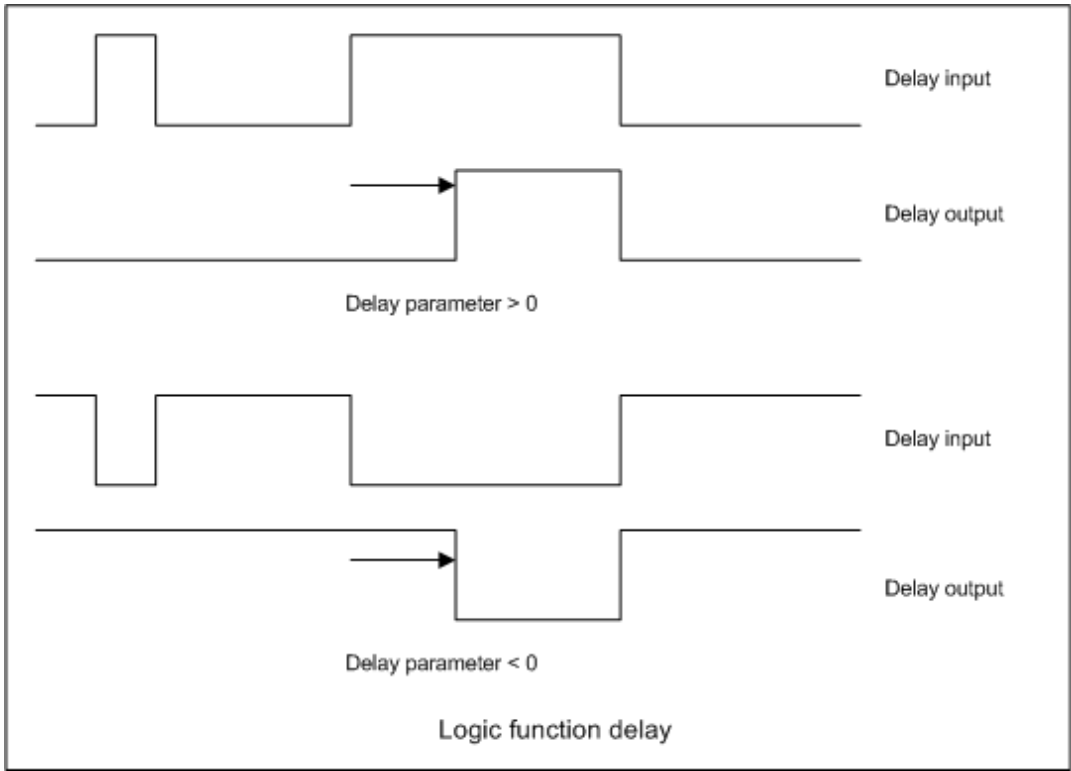

Motorised pot

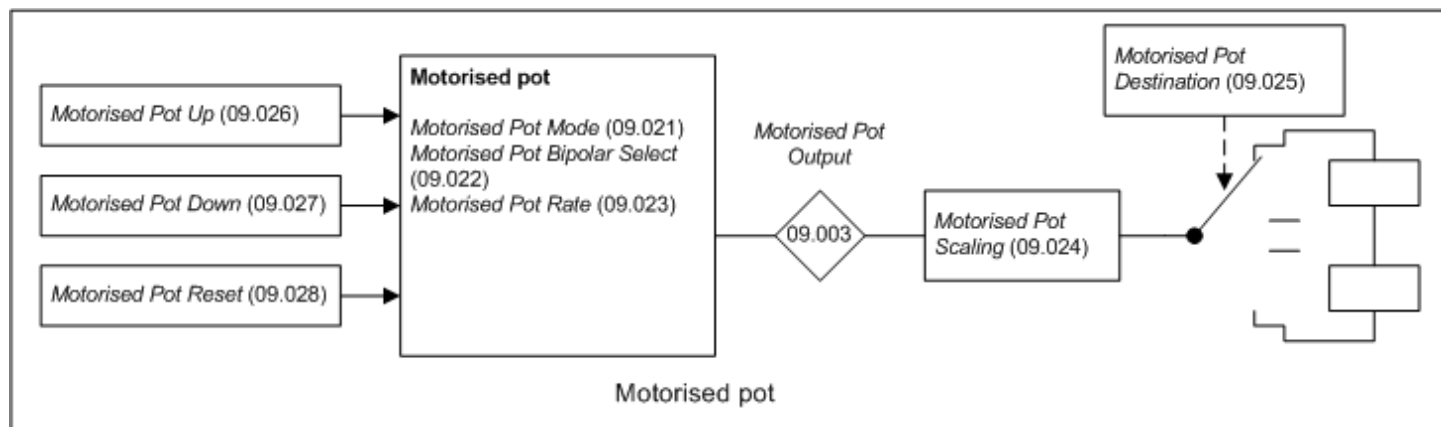

If *Motorised Pot Reset* (09.028) = 1 then the motorised pot is disabled and held in its reset state with *Motorised Pot Output* (09.003) = 0.0%. If *Motorised Pot Reset* (09.028) = 0 the motorised pot is enabled even if *Motorised Pot Destination* (09.025) is not routed to a valid parameter. The sample rate of the motorised pot is always 4ms.

When the motorised pot is active *Motorised Pot Output* (09.003) can be increased or decreased by setting *Motorised Pot Up* (09.026) or *Motorised Pot Down* (09.027) to 1 respectively. If both *Motorised Pot Up* (09.026) and *Motorised Pot Down* (09.027) are 1 then *Motorised Pot Output* (09.003) is increased. The rate of change of *Motorised Pot Output* (09.003) is defined by *Motorised Pot Rate* (09.023) which gives the time to change from 0 to 100%. The time to change from -100% to 100% is *Motorised Pot Rate* (09.023) x 2. If *Motorised Pot Bipolar Select* (09.022) = 0 then *Motorised Pot Output* (09.003) is limited in the range 0.00% to 100.00%, otherwise it is allowed to change in the range from -100.00% to 100.00%.

Motorised Pot Mode (09.021) defines the mode of operation as given in the table below.

<i>Motorised Pot Mode</i> (09.021)	<i>Motorised Pot Output</i> (09.003)	<i>Motorised Pot Up</i> (09.026) and <i>Motorised Pot Down</i> (09.027) active
0	Reset to zero at power-up	Always
1	Set to power-down value at power-up	Always
2	Reset to zero at power-up	When <i>Drive Active</i> (10.002) = 1
3	Set to power-down value at power-up	When <i>Drive Active</i> (10.002) = 1
4	Reset to zero at power-up and when <i>Drive Active</i> (10.002) = 0	When <i>Drive Active</i> (10.002) = 1

Motorised Pot Scaling (09.024) introduces a scaling factor at the output of the motorised pot before the output is routed to the destination. If *Motorised Pot Scaling* (09.024) *Motorised Pot Scaling* (09.024) > 1.000 the output will exceed the range of the destination parameter, and so the destination parameter will be at its maximum or minimum before the output of the motorised pot reaches the limits of its range.

Binary sum function

The binary sum function is always active even if the destination is not routed to valid a parameter. The update rate for the binary sum is always 4ms.

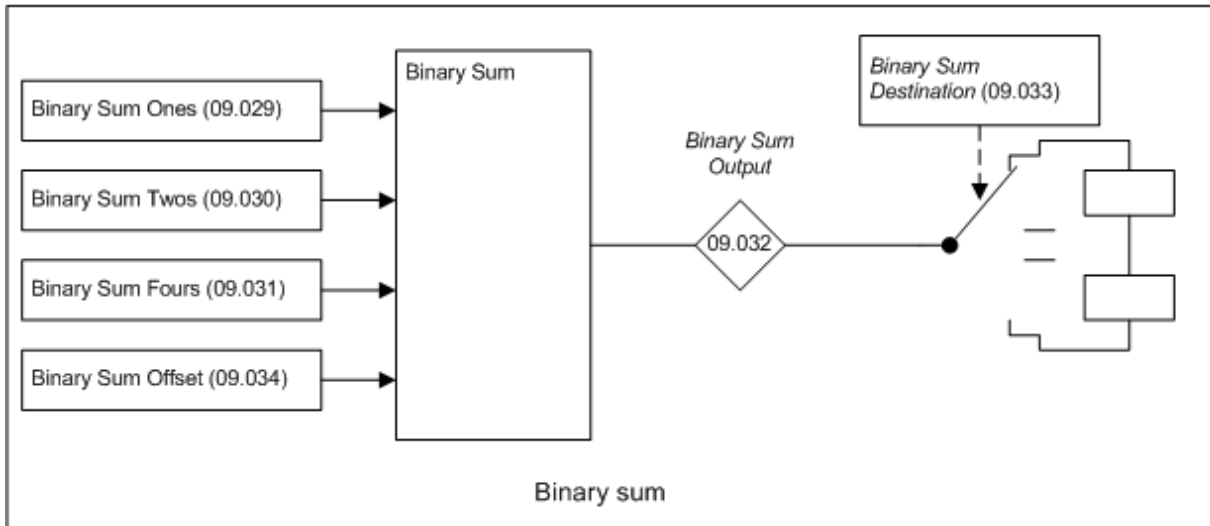

The output of the binary sum block is given by:

$$\text{Binary Sum Output (09.032)} = \text{Binary Sum Offset (09.034)} + (\text{Binary Sum Ones (09.029)} \times 1) + (\text{Binary Sum Twos (09.030)} \times 2) + (\text{Binary Sum Fours (09.031)} \times 4)$$

Binary Sum Destination (09.033) defines the destination for the binary sum output. The routing for this destination is special if the maximum of the destination parameter $\leq 7 + \text{Binary Sum Offset (09.034)}$ as follows:

Destination parameter = *Binary Sum Output (09.032)*, subject to the parameter minimum.

If the maximum of the destination parameter $> 7 + \text{Binary Sum Offset (09.034)}$, *Binary Sum Output (09.032)* is routed in the same way as any other destination where the destination target is at its full scale value when the *Binary Sum Output (09.032)* = $7 + \text{Binary Sum Offset (09.034)}$.

Timers

If the enable input to a timer is active and the repeat function is set to a non-zero value then the timer is active even if the destination is not routed to valid a parameter. The timers are updated in the background task and have a resolution of 1s.

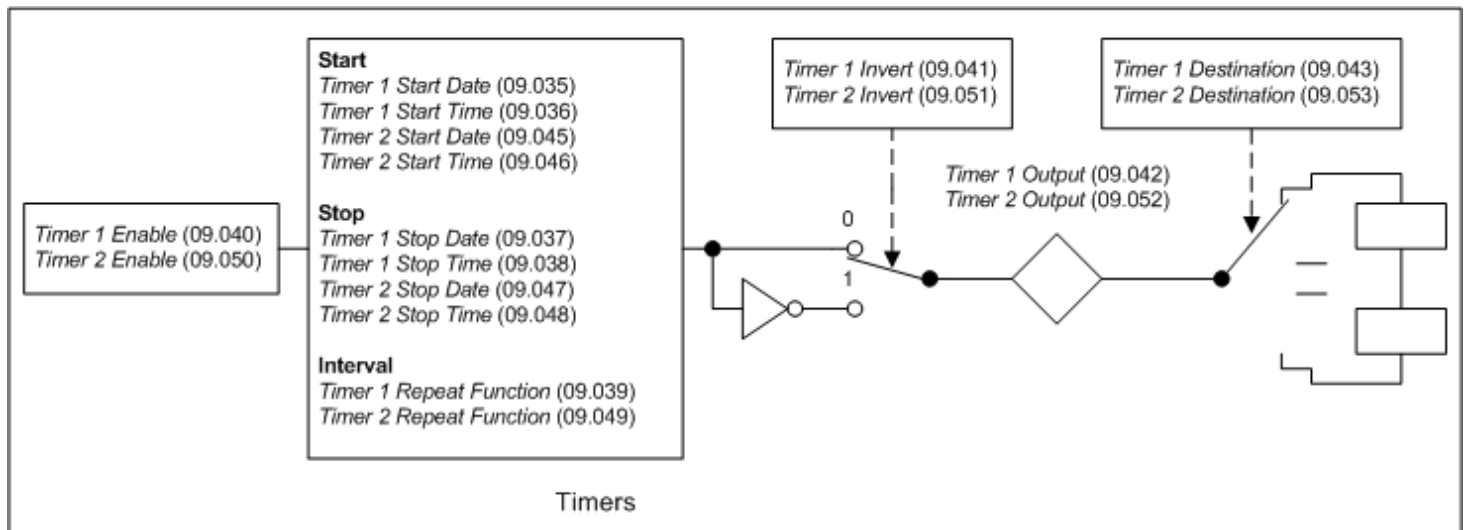

The following is a description of Timer 1, but Timer 2 behaves in the same way. If *Timer 1 Invert* (09.041) = 0 then *Timer 1 Output* (09.042) is inactive before the *Timer 1 Start Date* (09.035) / *Timer 1 Start Time* (09.036), active between this date/time and *Timer 1 Stop Date* (09.037) / *Timer 1 Stop Time* (09.038) and then inactive after the stop time/date within the timer 1 repeat period as shown in the diagram below.

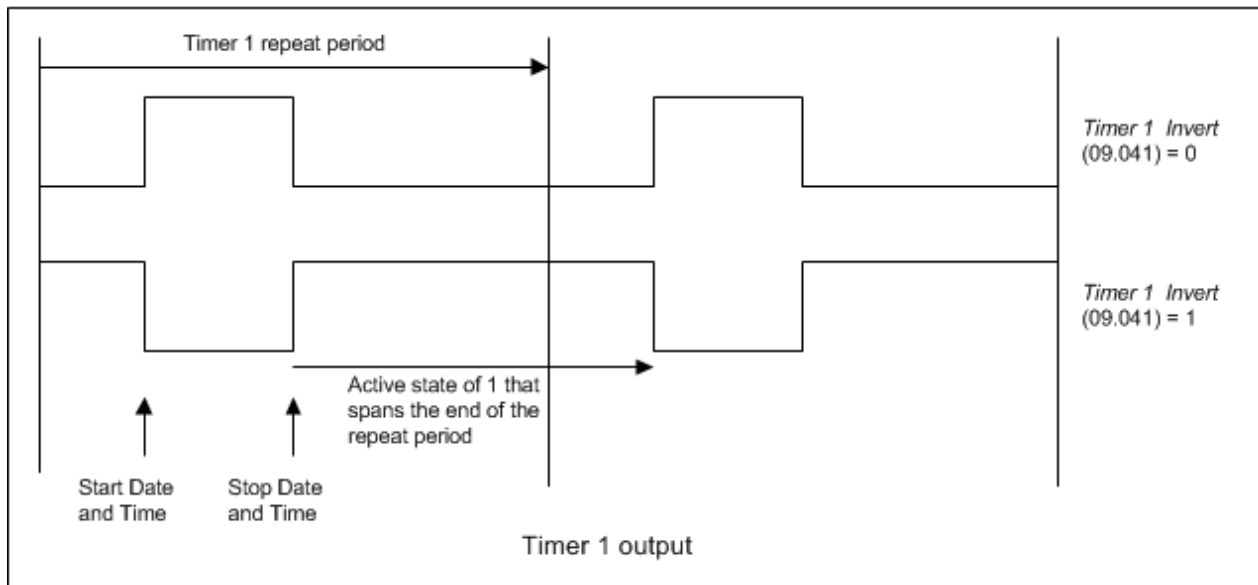

Timer 1 Repeat Function (09.039) defines the length of the repeat period. For example, if *Timer 1 Repeat Function* (09.039) = 2 then the repeat period is one day. The output is inactive until the time reaches the hour, minute and second defined in *Timer 1 Start Time* (09.036), and remains active until the time reaches the hour, minute and second defined in *Timer 1 Stop Time* (09.038). Different repeat periods may be selected as given in the table below. The table shows the constituent parts of the date and time that are used to determine the start and stop events. If the repeat period is set to every week then *Timer 1 Start Date* (09.035) and *Timer 1 Stop Date* (09.037) define the day of the week and not the date (i.e. 00.00.00 = Sunday, 00.00.01 = Monday, etc.). The week repeat period starts at 00.00.00 on Sunday morning and ends at 23.59.59 on Saturday night. If the stop time event is set to occur at or before the start time event or the *Timer 1 Repeat Function* (09.039) = 0 or *Timer 1 Enable* (09.040) = 0 the output remains inactive at all times (i.e. *Timer 1 Output* (09.042) = 0 if *Timer 1 Invert* (09.041) = 0).

<i>Timer 1 Repeat Function</i> (09.039)	Repeat period	Second	Minute	Hour	Day	Month	Year	Day of week
0	None							
1	Hour	.	.					
2	Day	.	.	.				
3	Week
4	Month			
5	Year		
6	One off	
7	Minute	.						

As *Timer 1 Invert* (09.041) inverts the timer output it can be used to give an active state of 0 instead of 1. Alternatively it can be used to give an active state of 1, but for a time period that spans the ends of the repeat period as shown in the example above. It should be noted that if this method is used to allow the active period to span the ends of the repeat period then if the timer is disabled the output of the timer block before the invert becomes 0, and so the final output of the timer after the invert is 1.

If *Date/Time Selector* (06.019) is changed and the drive is reset then the source for the timers will change, therefore *Timer 1 Repeat Function* (09.039) and *Timer 2 Repeat Function* (09.049) are reset to 0 to disable the timers, and the date and time entries in the trip log are cleared.

Scope function

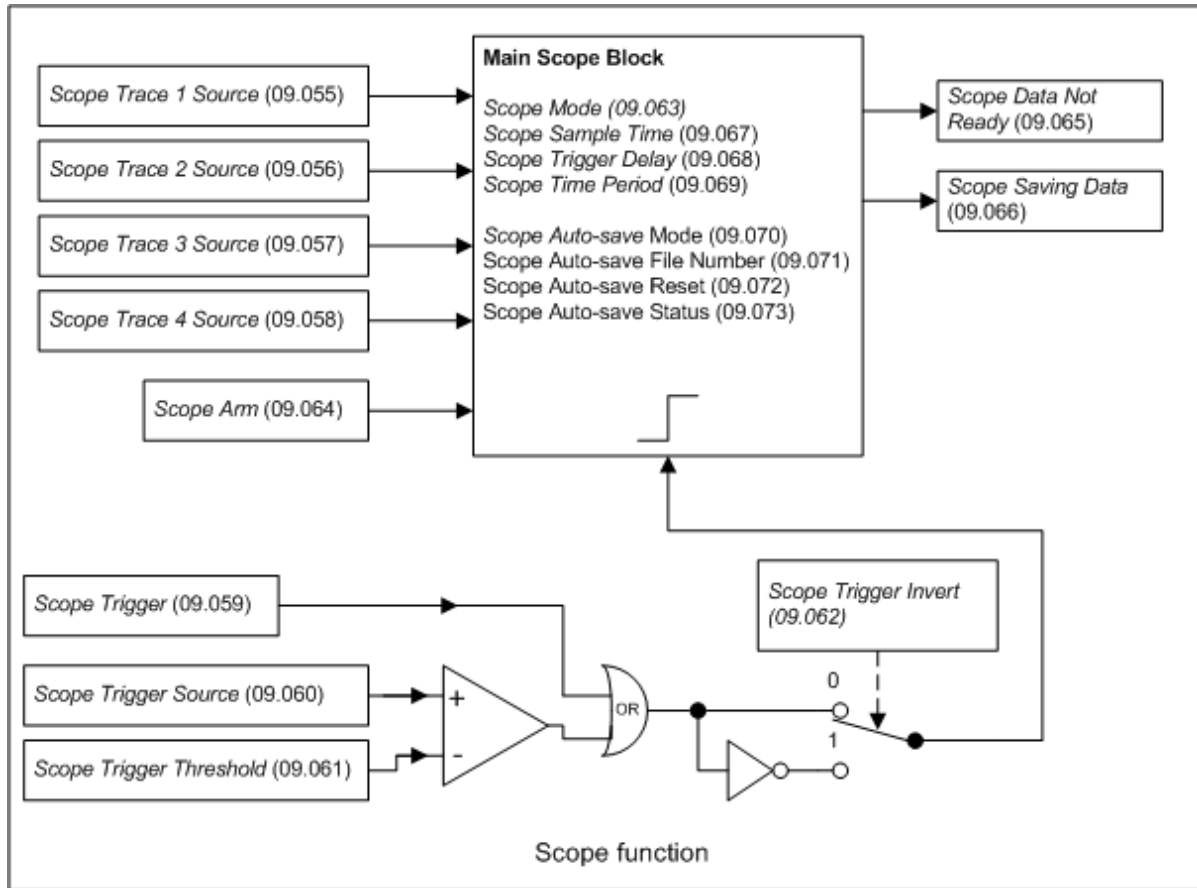

Parameter	09.001 Logic Function 1 Output		
Short description	Shows the output state of logic function 1		
Mode	Regeneration		
Minimum	0	Maximum	1
Default		Units	
Type	1 Bit Volatile	Update Rate	4ms write
Display Format	Standard	Decimal Places	0
Coding	RO, ND, NC, PT		

Logic Function 1 Output (09.001) shows the output of logic function 1.

Parameter	09.002 Logic Function 2 Output		
Short description	Shows the output state of logic function 2		
Mode	Regeneration		
Minimum	0	Maximum	1
Default		Units	
Type	1 Bit Volatile	Update Rate	4ms write
Display Format	Standard	Decimal Places	0
Coding	RO, ND, NC, PT		

Logic Function 2 Output (09.002) shows the output of logic function 2.

Parameter	09.003 Motorised Pot Output		
Short description	Shows the output level of the motorised pot function		
Mode	Regeneration		
Minimum	-100.00	Maximum	100.00
Default		Units	%
Type	16 Bit Power Down Save	Update Rate	4ms write
Display Format	Standard	Decimal Places	2
Coding	RO, ND, NC, PT		

Motorised Pot Output (09.003) shows the output of the motorised pot function.

Parameter	09.004 Logic Function 1 Source 1		
Short description	Defines input source 1 of logic function 1		
Mode	Regeneration		
Minimum	0.000	Maximum	59.999
Default	0.000	Units	
Type	16 Bit User Save	Update Rate	Drive reset read
Display Format	Standard	Decimal Places	3
Coding	RW, PT, BU		

Logic Function 1 Source 1 (09.004) defines input source 1 of logic function 1.

Parameter	09.005 Logic Function 1 Source 1 Invert		
Short description	Set to invert input 1 of logic function 1		
Mode	Regeneration		
Minimum	0	Maximum	1
Default	0	Units	
Type	1 Bit User Save	Update Rate	4ms read
Display Format	Standard	Decimal Places	0
Coding	RW		

Setting Logic Function 1 Source 1 Invert (09.005) inverts input 1 of logic function 1.

Parameter	09.006 Logic Function 1 Source 2		
Short description	Defines input source 2 of logic function 1		
Mode	Regeneration		
Minimum	0.000	Maximum	59.999
Default	0.000	Units	
Type	16 Bit User Save	Update Rate	Drive reset read
Display Format	Standard	Decimal Places	3
Coding	RW, PT, BU		

Logic Function 1 Source 2 (09.006) defines input source 2 of logic function 1.

Parameter	09.007 Logic Function 1 Source 2 Invert		
Short description	Set to invert input 2 of logic function 1		
Mode	Regeneration		
Minimum	0	Maximum	1
Default	0	Units	
Type	1 Bit User Save	Update Rate	4ms read
Display Format	Standard	Decimal Places	0
Coding	RW		

Setting Logic Function 1 Source 2 Invert (09.007) inverts input 2 of logic function 1.

Parameter	09.008 Logic Function 1 Output Invert		
Short description	Set to invert the output of logic function 1		
Mode	Regeneration		
Minimum	0	Maximum	1
Default	0	Units	
Type	1 Bit User Save	Update Rate	4ms read
Display Format	Standard	Decimal Places	0
Coding	RW		

Setting Logic Function 1 Output Invert (09.008) inverts the output of logic function 1.

Parameter	09.009 Logic Function 1 Delay		
Short description	Defines the output delay of logic function 1		
Mode	Regeneration		
Minimum	-25.0	Maximum	25.0
Default	0.0	Units	s
Type	16 Bit User Save	Update Rate	4ms read
Display Format	Standard	Decimal Places	1
Coding	RW		

Logic Function 1 Delay (09.009) defines the delay at the output of logic function 1. If Logic Function 1 Delay (09.009) is positive then the output does not become 1 until the input to the delay has been at 1 for the delay time. If Logic Function 1 Delay (09.009) is negative then the output remains at 1 until the input to the delay has been 0 for the delay time.

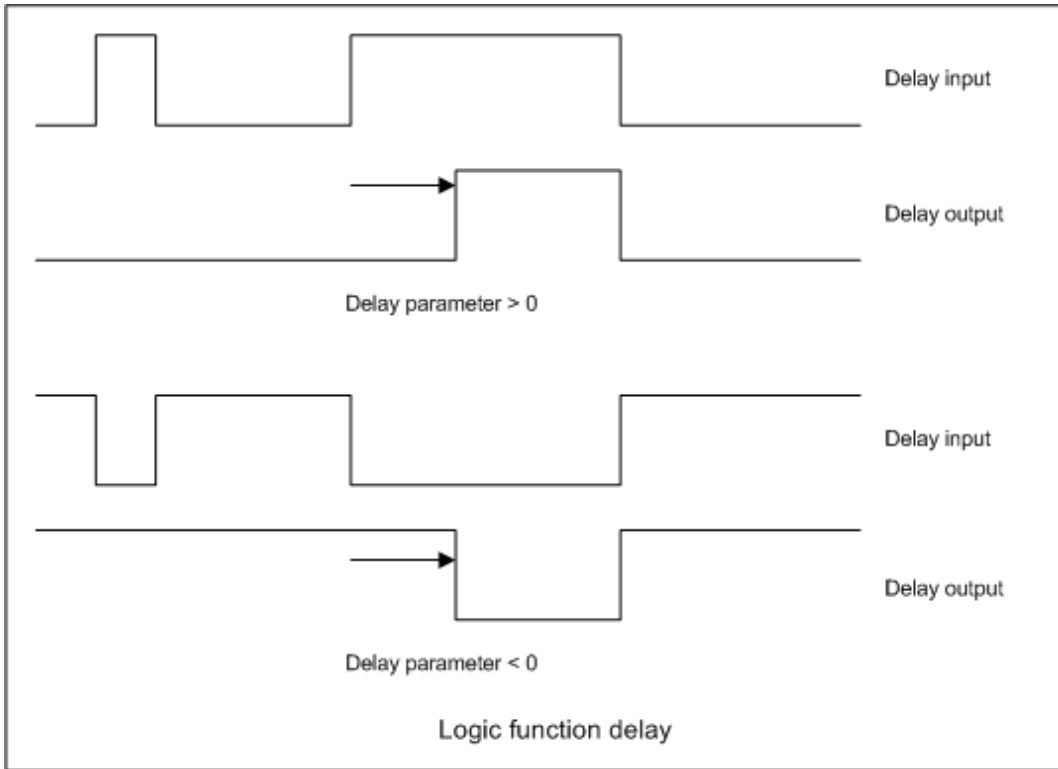

Parameter	09.010 Logic Function 1 Destination		
Short description	Defines the output destination of logic function 1		
Mode	Regeneration		
Minimum	0.000	Maximum	59.999
Default	0.000	Units	
Type	16 Bit User Save	Update Rate	Drive reset read
Display Format	Standard	Decimal Places	3
Coding	RW, DE, PT, BU		

Logic Function 1 Destination (09.010) defines the output destination of logic function 1.

Parameter	09.014 Logic Function 2 Source 1		
Short description	Defines input source 1 of logic function 2		
Mode	Regeneration		
Minimum	0.000	Maximum	59.999
Default	0.000	Units	
Type	16 Bit User Save	Update Rate	Drive reset read
Display Format	Standard	Decimal Places	3
Coding	RW, PT, BU		

Logic Function 2 Source 1 (09.014) defines input source 1 of logic function 2.

Parameter	09.015 Logic Function 2 Source 1 Invert		
Short description	Set to invert input 1 of logic function 2		
Mode	Regeneration		
Minimum	0	Maximum	1
Default	0	Units	
Type	1 Bit User Save	Update Rate	4ms read
Display Format	Standard	Decimal Places	0
Coding	RW		

Setting Logic Function 2 Source 1 Invert (09.015) inverts input 1 of logic function 2.

Parameter	09.016 Logic Function 2 Source 2		
Short description	Defines input source 2 of logic function 2		
Mode	Regeneration		
Minimum	0.000	Maximum	59.999
Default	0.000	Units	
Type	16 Bit User Save	Update Rate	Drive reset read
Display Format	Standard	Decimal Places	3
Coding	RW, PT, BU		

Logic Function 2 Source 2 (09.016) defines input source 2 of logic function 2.

Parameter	09.017 Logic Function 2 Source 2 Invert		
Short description	Set to invert input 2 of logic function 2		
Mode	Regeneration		
Minimum	0	Maximum	1
Default	0	Units	
Type	1 Bit User Save	Update Rate	4ms read
Display Format	Standard	Decimal Places	0
Coding	RW		

Setting Logic Function 2 Source 2 Invert (09.017) inverts input 2 of logic function 2.

Parameter	09.018 Logic Function 2 Output Invert		
Short description	Set to invert the output of logic function 2		
Mode	Regeneration		
Minimum	0	Maximum	1
Default	0	Units	
Type	1 Bit User Save	Update Rate	4ms read
Display Format	Standard	Decimal Places	0
Coding	RW		

Setting Logic Function 2 Output Invert (09.018) inverts the output of logic function 2.

Parameter	09.019 Logic Function 2 Delay		
Short description	Defines the output delay of logic function 2		
Mode	Regeneration		
Minimum	-25.0	Maximum	25.0
Default	0.0	Units	s
Type	16 Bit User Save	Update Rate	4ms read
Display Format	Standard	Decimal Places	1
Coding	RW		

Logic Function 2 Delay (09.019) defines the delay at the output of logic function 1. If Logic Function 2 Delay (09.019) is positive then the output does not become 1 until the input to the delay has been at 1 for the delay time. If Logic Function 2 Delay (09.019) is negative then the output remains at 1 until the input to the delay has been 0 for the delay time.

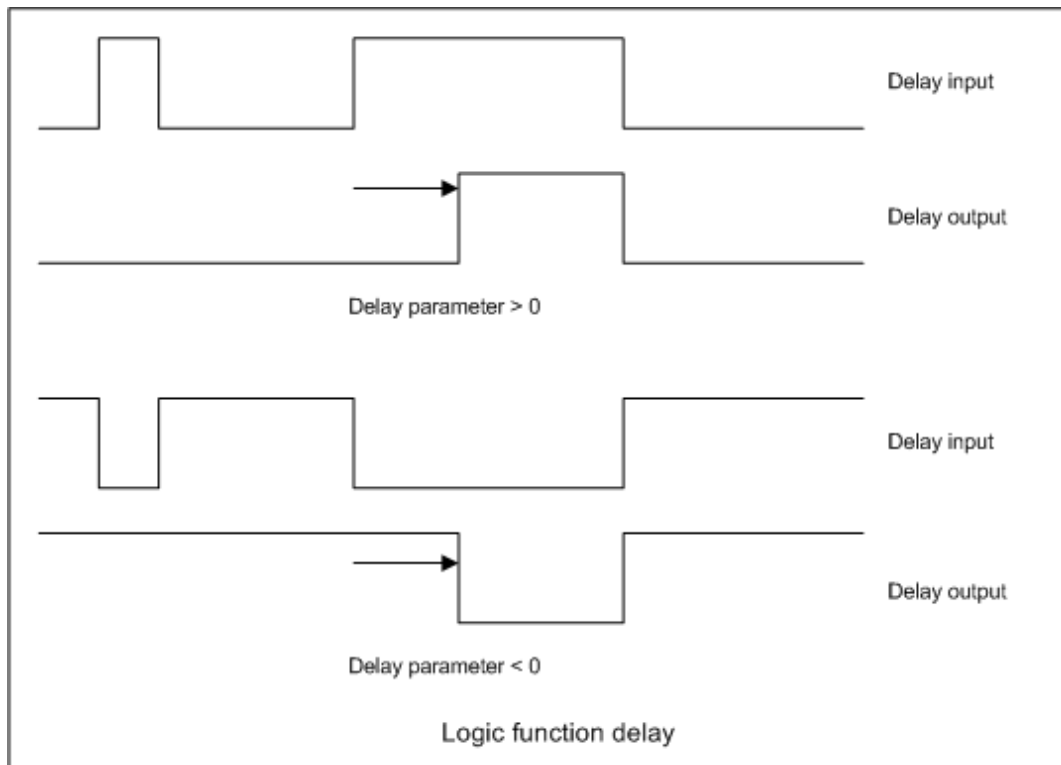

Parameter	09.020 Logic Function 2 Destination		
Short description	Defines the output destination of logic function 2		
Mode	Regeneration		
Minimum	0.000	Maximum	59.999
Default	0.000	Units	
Type	16 Bit User Save	Update Rate	Drive reset read
Display Format	Standard	Decimal Places	3
Coding	RW, DE, PT, BU		

Logic Function 2 Destination (09.020) defines the output destination of logic function 2.

Parameter	09.021 Motorised Pot Mode		
Short description	Defines the motorised pot mode		
Mode	Regeneration		
Minimum	0	Maximum	4
Default	0	Units	
Type	8 Bit User Save	Update Rate	Background read
Display Format	Standard	Decimal Places	0
Coding	RW		

Motorised Pot Mode (09.021) defines the mode of operation as given in the table below.

Motorised Pot Mode (09.021)	Motorised Pot Output (09.003)	Motorised Pot Up (09.026) and Motorised Pot Down (09.027) active
0	Reset to zero at power-up	Always
1	Set to power-down value at power-up	Always
2	Reset to zero at power-up	When <i>Drive Active</i> (10.002) = 1
3	Set to power-down value at power-up	When <i>Drive Active</i> (10.002) = 1
4	Reset to zero at power-up and when <i>Drive Active</i> (10.002) = 0	When <i>Drive Active</i> (10.002) = 1

Parameter	09.022 Motorised Pot Bipolar Select		
Short description	Set to enable bipolar operation of the motorised pot		
Mode	Regeneration		
Minimum	0	Maximum	1
Default	0	Units	
Type	1 Bit User Save	Update Rate	4ms read
Display Format	Standard	Decimal Places	0
Coding	RW		

If *Motorised Pot Bipolar Select* (09.022) = 0 then *Motorised Pot Output* (09.003) is limited in the range 0.00% to 100.00%, otherwise it is allowed to change in the range from -100.00% to 100.00%.

Parameter	09.023 Motorised Pot Rate		
Short description	Defines the rate of change of the motorised pot output		
Mode	Regeneration		
Minimum	0	Maximum	250
Default	20	Units	s
Type	8 Bit User Save	Update Rate	Background
Display Format	Standard	Decimal Places	0
Coding	RW, BU		

The rate of change of *Motorised Pot Output* (09.003) is defined by *Motorised Pot Rate* (09.023) which gives the time to change from 0 to 100%. The time to change from -100% to 100% is *Motorised Pot Rate* (09.023) x 2.

Parameter	09.024 Motorised Pot Scaling		
Short description	Defines the scaling factor for the motorised pot output		
Mode	Regeneration		
Minimum	0.000	Maximum	4.000
Default	1.000	Units	
Type	16 Bit User Save	Update Rate	4ms read
Display Format	Standard	Decimal Places	3
Coding	RW		

Motorised Pot Scaling (09.024) introduces a scaling factor at the output of the motorised pot before the output is routed to the destination. If *Motorised Pot Scaling* (09.024) > 1.000 the output will exceed the range of the destination parameter, and so the destination parameter will be at its maximum or minimum before the output of the motorised pot reaches the limits of its range.

Parameter	09.025 <i>Motorised Pot Destination</i>		
Short description	Defines the output destination of the motorised pot		
Mode	Regeneration		
Minimum	0.000	Maximum	59.999
Default	0.000	Units	
Type	16 Bit User Save	Update Rate	Drive reset read
Display Format	Standard	Decimal Places	3
Coding	RW, DE, PT, BU		

Logic Function 2 Destination (09.020) defines the output destination of the motorised pot function.

Parameter	09.026 <i>Motorised Pot Up</i>		
Short description	Set to increase the motorised pot output		
Mode	Regeneration		
Minimum	0	Maximum	1
Default	0	Units	
Type	1 Bit Volatile	Update Rate	4ms read
Display Format	Standard	Decimal Places	0
Coding	RW, NC		

If *Motorised Pot Up* (09.026) = 1, then the *Motorised Pot Output* (09.003) will increase.

Parameter	09.027 <i>Motorised Pot Down</i>		
Short description	Set to decrease the motorised pot output		
Mode	Regeneration		
Minimum	0	Maximum	1
Default	0	Units	
Type	1 Bit Volatile	Update Rate	4ms read
Display Format	Standard	Decimal Places	0
Coding	RW, NC		

If *Motorised Pot Down* (09.027) = 1, then the *Motorised Pot Output* (09.003) will decrease.

Parameter	09.028 <i>Motorised Pot Reset</i>		
Short description	Set to reset the motorised pot output to zero		
Mode	Regeneration		
Minimum	0	Maximum	1
Default	0	Units	
Type	1 Bit Volatile	Update Rate	4ms read
Display Format	Standard	Decimal Places	0
Coding	RW, NC		

If *Motorised Pot Reset* (09.028) = 1 then the motorised pot is disabled and held in its reset state with *Motorised Pot Output* (09.003) = 0.0%. If *Motorised Pot Reset* (09.028) = 0 the motorised pot is enabled even if *Motorised Pot Destination* (09.025) is not routed to a valid parameter.

Parameter	09.029 <i>Binary Sum Ones</i>		
Short description	Set to add one to the binary sum output		
Mode	Regeneration		
Minimum	0	Maximum	1
Default	0	Units	
Type	1 Bit Volatile	Update Rate	4ms read
Display Format	Standard	Decimal Places	0
Coding	RW, NC		

See *Binary Sum Output* (09.032).

Parameter	09.030 <i>Binary Sum Twos</i>		
Short description	Set to add two to the binary sum output		
Mode	Regeneration		
Minimum	0	Maximum	1
Default	0	Units	
Type	1 Bit Volatile	Update Rate	4ms read
Display Format	Standard	Decimal Places	0
Coding	RW, NC		

See *Binary Sum Output* (09.032).

Parameter	09.031 Binary Sum Fours		
Short description	Set to add three to the binary sum output		
Mode	Regeneration		
Minimum	0	Maximum	1
Default	0	Units	
Type	1 Bit Volatile	Update Rate	4ms read
Display Format	Standard	Decimal Places	0
Coding	RW, NC		

See *Binary Sum Output* (09.032).

Parameter	09.032 Binary Sum Output		
Short description	Shows the output level of the binary sum		
Mode	Regeneration		
Minimum	0	Maximum	255
Default		Units	
Type	8 Bit Volatile	Update Rate	4ms write
Display Format	Standard	Decimal Places	0
Coding	RO, ND, NC, PT, BU		

The output of the binary sum block is given by:

$$\text{Binary Sum Output (09.032)} = \text{Binary Sum Offset (09.034)} + (\text{Binary Sum Ones (09.029)} \times 1) + (\text{Binary Sum Twos (09.030)} \times 2) + (\text{Binary Sum Fours (09.031)} \times 4)$$

Binary Sum Destination (09.033) defines the destination for the binary sum output. The routing for this destination is special if the maximum of the destination parameter $\leq 7 + \text{Binary Sum Offset}$ (09.034) as follows:

Destination parameter = *Binary Sum Output* (09.032), subject to the parameter minimum.

If the maximum of the destination parameter > 7 , *Binary Sum Output* (09.032) is routed in the same way as any other destination where the destination target is at its full scale value when the *Binary Sum Output* (09.032) = $7 + \text{Binary Sum Offset}$ (09.034).

Parameter	09.033 Binary Sum Destination		
Short description	Defines the output destination of the binary sum		
Mode	Regeneration		
Minimum	0.000	Maximum	59.999
Default	0.000	Units	
Type	16 Bit User Save	Update Rate	Drive reset read
Display Format	Standard	Decimal Places	3
Coding	RW, DE, PT, BU		

Binary Sum Destination (09.033) defines the destination for the binary sum output.

See *Binary Sum Output* (09.032) for more information.

Parameter	09.034 Binary Sum Offset		
Short description	Defines the offset added to the output of the binary sum		
Mode	Regeneration		
Minimum	0	Maximum	248
Default	0	Units	
Type	8 Bit User Save	Update Rate	4ms read
Display Format	Standard	Decimal Places	0
Coding	RW, BU		

See *Binary Sum Output* (09.032).

Parameter	09.035 Timer 1 Start Date		
Short description	Defines the start date for timer 1		
Mode	Regeneration		
Minimum	0 (Display: 00-00-00)	Maximum	311299 (Display: 31-12-99)
Default	0 (Display: 00-00-00)	Units	
Type	32 Bit User Save	Update Rate	Background read
Display Format	Date	Decimal Places	0
Coding	RW		

Timer 1 Start Date (09.035) defines the start date within the repeat period of timer 1.

See *Timer 1 Repeat Function* (09.039) for more information.

Parameter	09.036 <i>Timer 1 Start Time</i>		
Short description	Defines the start time for timer 1		
Mode	Regeneration		
Minimum	0 (Display: 00:00:00)	Maximum	235959 (Display: 23:59:59)
Default	0 (Display: 00:00:00)	Units	
Type	32 Bit User Save	Update Rate	Background read
Display Format	Time	Decimal Places	0
Coding	RW		

Timer 1 Start Time (09.036) defines the start time within the repeat period of timer 1.

See *Timer 1 Repeat Function* (09.039) for more information.

Parameter	09.037 <i>Timer 1 Stop Date</i>		
Short description	Defines the stop date for timer 1		
Mode	Regeneration		
Minimum	0 (Display: 00-00-00)	Maximum	311299 (Display: 31-12-99)
Default	0 (Display: 00-00-00)	Units	
Type	32 Bit User Save	Update Rate	Background read
Display Format	Date	Decimal Places	0
Coding	RW		

Timer 1 Stop Date (09.037) defines the stop date within the repeat period of timer 1.

See *Timer 1 Repeat Function* (09.039) for more information.

Parameter	09.038 <i>Timer 1 Stop Time</i>		
Short description	Defines the stop time for timer 1		
Mode	Regeneration		
Minimum	0 (Display: 00:00:00)	Maximum	235959 (Display: 23:59:59)
Default	0 (Display: 00:00:00)	Units	
Type	32 Bit User Save	Update Rate	Background read
Display Format	Time	Decimal Places	0
Coding	RW		

Timer 1 Stop Time (09.038) defines the stop time within the repeat period of timer 1.

See *Timer 1 Repeat Function* (09.039) for more information.

Parameter	09.039 <i>Timer 1 Repeat Function</i>		
Short description	Defines the length of the repeat period		
Mode	Regeneration		
Minimum	0	Maximum	7
Default	0	Units	
Type	8 Bit User Save	Update Rate	Background read
Display Format	Standard	Decimal Places	0
Coding	RW, TE		

Value	Text
0	None
1	Hour
2	Day
3	Week
4	Month
5	Year
6	One off
7	Minute

Timer 1 Repeat Function (09.039) defines the length of the repeat period. For example, if *Timer 1 Repeat Function* (09.039) = 2 then the repeat period is one day. The result is inactive until the time reaches the hour, minute and second defined in *Timer 1 Start Time* (09.036), and remains active until the time reaches the hour, minute and second defined in *Timer 1 Stop Time* (09.038). Different repeat periods may be selected as given in the table below. The table shows the constituent parts of the date and time that are used to determine the start and stop events. If the repeat period is set to every week then *Timer 1 Start Date* (09.035) and *Timer 1 Stop Date* (09.037) define the day of the week and not the date (i.e. 00.00.00 = Sunday, 00.00.01 = Monday, etc.). If the stop time event is set to occur at or before the start time event or the *Timer 1 Repeat Function* (09.039) = 0 or *Timer 1 Enable* (09.040) = 0 the result remains inactive at all times (i.e. *Timer 1 Output* (09.042) = 0 if *Timer 1 Invert* (09.041) = 0).

Timer 1 Repeat Function (09.039)	Repeat period	Second	Minute	Hour	Day	Month	Year	Day of week
0	None							
1	Hour	.	.					
2	Day	.	.	.				
3	Week
4	Month			
5	Year		
6	One off	
7	Minute	.						

Parameter	09.040 Timer 1 Enable		
Short description	Set to enable the timer 1 function		
Mode	Regeneration		
Minimum	0	Maximum	1
Default	0	Units	
Type	1 Bit User Save	Update Rate	Background read
Display Format	Standard	Decimal Places	0
Coding	RW		

Timer 1 Enable (09.040) enables the timer 1 function. If *Timer 1 Enable* (09.040) = 0, then the output of the timer is always inactive, i.e. *Timer 1 Output* (09.042) = 0.

Parameter	09.041 Timer 1 Invert		
Short description	Set to invert the output of timer 1		
Mode	Regeneration		
Minimum	0	Maximum	1
Default	0	Units	
Type	1 Bit User Save	Update Rate	Background read
Display Format	Standard	Decimal Places	0
Coding	RW		

Timer 1 Invert (09.041) inverts the timer output to give an active state of 0 instead of 1. Alternatively it can be used to give an active state of 1, but for a time period that spans the ends of the repeat period as shown in the example above. It should be noted that if this method is used to allow the active period to span the ends of the repeat period then if the timer is disabled the output of the timer block before the invert becomes 0, and so the final output of the timer after the invert is 1.

See *Timer 1 Repeat Function* (09.039) for more information.

Parameter	09.042 Timer 1 Output		
Short description	Shows the output state of timer function 1		
Mode	Regeneration		
Minimum	0	Maximum	1
Default		Units	
Type	1 Bit Volatile	Update Rate	Background write
Display Format	Standard	Decimal Places	0
Coding	RO, ND, NC, PT		

Timer 1 Output (09.042) shows the output of timer function 1.

Parameter	09.043 Timer 1 Destination		
Short description	Defines the output destination of timer function 1		
Mode	Regeneration		
Minimum	0.000	Maximum	59.999
Default	0.000	Units	
Type	16 Bit User Save	Update Rate	Drive reset read
Display Format	Standard	Decimal Places	3
Coding	RW, DE, PT, BU		

Timer 1 Destination (09.043) defines the output destination of timer function 1.

Parameter	09.045 Timer 2 Start Date		
Short description	Defines the start date for timer 2		
Mode	Regeneration		
Minimum	0 (Display: 00-00-00)	Maximum	311299 (Display: 31-12-99)
Default	0 (Display: 00-00-00)	Units	
Type	32 Bit User Save	Update Rate	Background read
Display Format	Date	Decimal Places	0
Coding	RW		

Timer 2 Start Date (09.045) defines the start date within the repeat period of timer 2.

See *Timer 1 Repeat Function* (09.039) for more information.

Parameter	09.046 Timer 2 Start Time		
Short description	Defines the start time for timer 2		
Mode	Regeneration		
Minimum	0 (Display: 00:00:00)	Maximum	235959 (Display: 23:59:59)
Default	0 (Display: 00:00:00)	Units	
Type	32 Bit User Save	Update Rate	Background read
Display Format	Time	Decimal Places	0
Coding	RW		

Timer 2 Start Time (09.046) defines the start time within the repeat period of timer 2.

See *Timer 1 Repeat Function* (09.039) for more information.

Parameter	09.047 Timer 2 Stop Date		
Short description	Defines the stop date for timer 2		
Mode	Regeneration		
Minimum	0 (Display: 00-00-00)	Maximum	311299 (Display: 31-12-99)
Default	0 (Display: 00-00-00)	Units	
Type	32 Bit User Save	Update Rate	Background read
Display Format	Date	Decimal Places	0
Coding	RW		

Timer 2 Stop Date (09.047) defines the stop date within the repeat period of timer 2.

See *Timer 1 Repeat Function* (09.039) for more information.

Parameter	09.048 Timer 2 Stop Time		
Short description	Defines the stop time for timer 2		
Mode	Regeneration		
Minimum	0 (Display: 00:00:00)	Maximum	235959 (Display: 23:59:59)
Default	0 (Display: 00:00:00)	Units	
Type	32 Bit User Save	Update Rate	Background read
Display Format	Time	Decimal Places	0
Coding	RW		

Timer 2 Stop Time (09.048) defines the stop time within the repeat period of timer 2.

See *Timer 1 Repeat Function* (09.039) for more information.

Parameter	09.049 Timer 2 Repeat Function		
Short description	Defines the length of the repeat period		
Mode	Regeneration		
Minimum	0	Maximum	7
Default	0	Units	
Type	8 Bit User Save	Update Rate	Background read
Display Format	Standard	Decimal Places	0
Coding	RW, TE		

Value	Text
0	None
1	Hour
2	Day
3	Week
4	Month
5	Year
6	One off
7	Minute

See *Timer 1 Repeat Function* (09.039).

Parameter	09.050 <i>Timer 2 Enable</i>		
Short description	Set to enable the timer 2 function		
Mode	Regeneration		
Minimum	0	Maximum	1
Default	0	Units	
Type	1 Bit User Save	Update Rate	Background read
Display Format	Standard	Decimal Places	0
Coding	RW		

Timer 2 Enable (09.050) enables the timer 2 function. If *Timer 2 Enable* (09.050) = 0, then the output of the timer is always inactive, i.e. *Timer 2 Output* (09.052) = 0.

Parameter	09.051 <i>Timer 2 Invert</i>		
Short description	Set to invert the output of timer 2		
Mode	Regeneration		
Minimum	0	Maximum	1
Default	0	Units	
Type	1 Bit User Save	Update Rate	Background read
Display Format	Standard	Decimal Places	0
Coding	RW		

Timer 2 Invert (09.051) inverts the timer output to give an active state of 0 instead of 1.

See *Timer 1 Invert* (09.041) for more information.

Parameter	09.052 <i>Timer 2 Output</i>		
Short description	Shows the output state of timer function 2		
Mode	Regeneration		
Minimum	0	Maximum	1
Default		Units	
Type	1 Bit Volatile	Update Rate	Background write
Display Format	Standard	Decimal Places	0
Coding	RO, ND, NC, PT		

Timer 2 Output (09.052) shows the output of timer function 2.

Parameter	09.053 <i>Timer 2 Destination</i>		
Short description	Defines the output destination of timer function 2		
Mode	Regeneration		
Minimum	0.000	Maximum	59.999
Default	0.000	Units	
Type	16 Bit User Save	Update Rate	Drive reset read
Display Format	Standard	Decimal Places	3
Coding	RW, DE, PT, BU		

Timer 2 Destination (09.053) defines the output destination of timer function 2.

Parameter	09.055 <i>Scope Trace 1 Source</i>		
Short description	Defines the source of scope trace 1		
Mode	Regeneration		
Minimum	0.000	Maximum	59.999
Default	0.000	Units	
Type	16 Bit User Save	Update Rate	Drive reset read
Display Format	Standard	Decimal Places	3
Coding	RW, PT, BU		

Up to four scope sources can be selected using *Scope Trace 1 Source* (09.055) to *Scope Trace 4 Source* (09.058). If the source value is set to 0.000, or the source parameter does not exist or is non-visible, then no source is selected. The sources do not operate in the same way as normal source

parameters in that the input to the scope is the actual value of the parameter and not a value scaled to a percentage based on the range of the parameter. If a scope trace source parameter is modified the actual change is not effective until the drive is reset.

Parameter	09.056 Scope Trace 2 Source		
Short description	Defines the source of scope trace 2		
Mode	Regeneration		
Minimum	0.000	Maximum	59.999
Default	0.000	Units	
Type	16 Bit User Save	Update Rate	Drive reset read
Display Format	Standard	Decimal Places	3
Coding	RW, PT, BU		

See *Scope Trace 1 Source* (09.055).

Parameter	09.057 Scope Trace 3 Source		
Short description	Defines the source of scope trace 3		
Mode	Regeneration		
Minimum	0.000	Maximum	59.999
Default	0.000	Units	
Type	16 Bit User Save	Update Rate	Drive reset read
Display Format	Standard	Decimal Places	3
Coding	RW, PT, BU		

See *Scope Trace 1 Source* (09.055).

Parameter	09.058 Scope Trace 4 Source		
Short description	Defines the source of scope trace 4		
Mode	Regeneration		
Minimum	0.000	Maximum	59.999
Default	0.000	Units	
Type	16 Bit User Save	Update Rate	Drive reset read
Display Format	Standard	Decimal Places	3
Coding	RW, PT, BU		

See *Scope Trace 1 Source* (09.055).

Parameter	09.059 Scope Trigger		
Short description	Set to trigger the scope function		
Mode	Regeneration		
Minimum	0	Maximum	1
Default	0	Units	
Type	1 Bit Volatile	Update Rate	250µs read
Display Format	Standard	Decimal Places	0
Coding	RW		

The scope is triggered by a rising edge at the input to the main scope block. If *Scope Trigger Source* (09.060) is set at its default value of 0.000 then the output of the trigger threshold comparator is 0, and so the scope can be triggered with *Scope Trigger* (09.059). *Scope Trigger Invert* (09.062) can be used to invert the trigger signal.

Parameter	09.060 Scope Trigger Source		
Short description	Defines the source of the scope trigger		
Mode	Regeneration		
Minimum	0.000	Maximum	59.999
Default	10.001	Units	
Type	16 Bit User Save	Update Rate	Background read
Display Format	Standard	Decimal Places	3
Coding	RW, PT, BU		

If *Scope Trigger* (09.059) = 0, the scope can be triggered based on the level of a parameter defined by *Scope Trigger Source* (09.060) and the *Scope Trigger Threshold* (09.061). This source operates in the same way as the trace sources and a direct comparison is made between the actual parameter value and the threshold. Decimal places are ignored. The threshold detector output is 1 when the value from the scope trigger source is greater than *Scope Trigger Threshold* (09.061). If *Scope Trigger Source* (09.060) = 0.000, or it is used to select a parameter that does not exist or is non-visible, then the output of the threshold detector is 0.

Parameter	09.061 Scope Trigger Threshold		
Short description	Defines the scope trigger threshold		
Mode	Regeneration		
Minimum	-2147483648	Maximum	2147483647
Default	0	Units	
Type	32 Bit User Save	Update Rate	Background read
Display Format	Standard	Decimal Places	0
Coding	RW		

See *Scope Trigger Source* (09.060).

Parameter	09.062 Scope Trigger Invert		
Short description	Set to invert the scope trigger		
Mode	Regeneration		
Minimum	0	Maximum	1
Default	1	Units	
Type	1 Bit User Save	Update Rate	Background read
Display Format	Standard	Decimal Places	0
Coding	RW		

See *Scope Trigger* (09.059).

Parameter	09.063 Scope Mode		
Short description	Defines the mode of the scope		
Mode	Regeneration		
Minimum	0	Maximum	2
Default	1	Units	
Type	8 Bit User Save	Update Rate	Background read
Display Format	Standard	Decimal Places	0
Coding	RW, TE		

Value	Text
0	Single
1	Normal
2	Auto

Single (0):

If *Scope Arm* (09.064) is set to 1 the scope starts to acquire pre-trigger data (i.e. enough data to provide information for the pre-trigger period) and *Scope Data Not Ready* (09.065) is set to 1. The scope can then be triggered on the next trigger event (i.e. a rising edge on the trigger input of the main scope block). Note that the scope can only be triggered once the required amount of pre-trigger data has been sampled. Failure to do this will result in the scope function not triggering correctly. When the trigger event occurs *Scope Arm* (09.064) is set to 0, and when the post-trigger data has been stored *Scope Data Not Ready* (09.065) is set to 0. If *Scope Auto-save Mode* (09.070) is non-zero, the data in the scope trace buffer is saved to a non-volatile media card fitted in the drive. When the save is complete (or data cannot be saved, i.e. no card fitted or no space left) the scope is ready again to receive data. If *Scope Arm* (09.064) is set to 1 the scope will start to acquire data again.

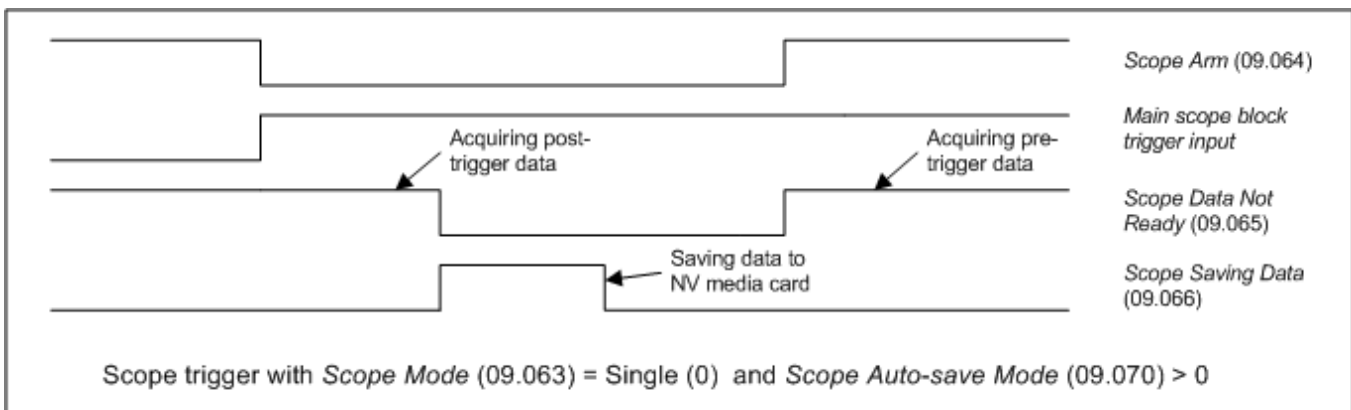

It is possible to read scope files via comms or into an option module. However, scope file transfer can only be initiated when *Scope Arm* (09.064) = 0, *Scope Data Not Ready* (09.065) = 0, *Scope Saving Data* (09.066) = 0 and at least one trace has been set up. While the file transfer is in progress *Scope Saving Data* (09.066) is set to 1.

The scope system is reset under any of the following conditions:

1. At power-up.
2. If the drive is reset when *Scope Trace 1 Source* (09.055) to *Scope Trace 4 Source* (09.058) have been modified.
3. The drive mode is changed.
4. If *Scope Mode* (09.063), *Scope Sample Time* (09.067) or *Scope Trigger Delay* (09.068) are modified.

When the scope is reset *Scope Arm* (09.064) is reset to 0 and the trace data is all cleared to 0..

Normal (1):

The scope operates in the same way as single mode except that *Scope Arm* (09.064) is automatically set back to 1 after a time delay of 1s once the post-trigger data has been acquired, and the scope data has been saved to a non-volatile media card if *Scope Auto-save Mode* (09.070) > 0.

Auto (2):

After the scope system is reset *Scope Data Not Ready* (09.065) is set to 1 and the scope begins to acquire data. Once the buffer is full *Scope Data Not Ready* (09.065) is set to 0 and the scope continues to acquire data. *Scope Arm* (09.064) has no effect on data acquisition. Provided *Scope Data Not Ready* (09.065) = 0 and *Scope Saving Data* (09.066) = 0 it is possible to read the data from the scope buffer as a scope file. Data acquisition is stopped when the file transfer begins. When the file transfer is complete, data acquisition begins again and *Scope Data Not Ready* (09.065) is set to 1 for a period that is long enough to fill the scope buffer with new data.

Parameter	09.064 Scope Arm		
Short description	Set to arm the scope		
Mode	Regeneration		
Minimum	0	Maximum	1
Default	0	Units	
Type	1 Bit Volatile	Update Rate	250µs read
Display Format	Standard	Decimal Places	0
Coding	RW, NC		

See *Scope Mode* (09.063).

Parameter	09.065 Scope Data Not Ready		
Short description	Shows that the data in the scope buffer is not ready to be read out		
Mode	Regeneration		
Minimum	0	Maximum	1
Default		Units	
Type	1 Bit Volatile	Update Rate	250µs write
Display Format	Standard	Decimal Places	0
Coding	RO, ND, NC, PT		

See *Scope Mode* (09.063).

Parameter	09.066 Scope Saving Data		
Short description	Shows when the scope is saving data		
Mode	Regeneration		
Minimum	0	Maximum	1
Default		Units	
Type	1 Bit Volatile	Update Rate	Background write
Display Format	Standard	Decimal Places	0
Coding	RO, ND, NC, PT		

See *Scope Mode* (09.063).

Parameter	09.067 Scope Sample Time		
Short description	Defines the sample time of the scope		
Mode	Regeneration		
Minimum	1	Maximum	200
Default	4	Units	
Type	8 Bit User Save	Update Rate	Background read
Display Format	Standard	Decimal Places	0
Coding	RW, BU		

Scope Sample Time (09.067) defines the sample rate of the scope function for all traces in 250µs units (i.e. if *Scope Sample Time* (09.067) = 4, the sample time is 1ms).

Parameter	09.068 Scope Trigger Delay		
Short description	Defines how much pre-trigger data is stored by the scope		
Mode	Regeneration		
Minimum	0	Maximum	100
Default	100	Units	%
Type	8 Bit User Save	Update Rate	Background read
Display Format	Standard	Decimal Places	0
Coding	RW		

Scope Trigger Delay (09.068) defines how much data is stored before and after the scope is triggered. If *Scope Trigger Delay* (09.068) = 0% then no data is stored before the trigger and all the data is after the trigger. If *Scope Trigger Delay* (09.068) = 100% then no data is stored after the trigger, but all the data is before the trigger.

Parameter	09.069 Scope Time Period		
Short description	Shows the time period covered by the scope buffer		
Mode	Regeneration		
Minimum	0.00	Maximum	200000.00
Default		Units	ms
Type	32 Bit Volatile	Update Rate	Background write
Display Format	Standard	Decimal Places	2
Coding	RO, ND, NC, PT		

The scope function can capture up to 4000 bytes of parameter data. The *Scope Time Period* (09.069) gives the length of the time period covered by the scope buffer in milliseconds which depends on the number of traces stored, the sample time and the size of the parameters used as trace sources.

Sample time in milliseconds = $(250 \times 10^{-6} \times \text{Scope Sample Time (09.067)}) \times 1000$

Size of trace data is the sum of the number of bytes in each of the trace sources selected by *Scope Trace 1 Source* (09.055) to *Scope Trace 4 Source* (09.058).

Scope Time Period (09.069) (ms) = $4000 \times \text{Sample time in milliseconds} / \text{Size of trace data}$

Parameter	09.070 Scope Auto-save Mode		
Short description	Defines the mode for auto-saving scope files to the NV media card		
Mode	Regeneration		
Minimum	0	Maximum	2
Default	0	Units	
Type	8 Bit User Save	Update Rate	Background read
Display Format	Standard	Decimal Places	0
Coding	RW, TE		

Value	Text
0	Disabled
1	Overwrite
2	Keep

Auto-save mode can be used to store a scope file on a non-volatile media card at each trigger event. The auto-save system is held in reset if *Scope Auto-save Reset* (09.072) = 1. When the auto-save system is reset all the scope files in scope file folder on the NV media card are deleted, *Scope Auto-save File Number* (09.071) is reset to 0 and the auto-save system is inactive. If any of the file operations fail during reset *Scope Auto-save Status* (09.073) is 3 (Failed) when the reset is removed.

The following conditions must be met for auto-saving to be active:

1. *Scope Auto-save Mode* (09.070) is non-zero
2. *Scope Auto-save Reset* (09.072) = 0
3. *Scope Auto-save Status* (09.073) = 1 (Active)
4. *Scope Mode* (09.063) = 0 (Single) or 1 (Normal)

If auto-saving is active an attempt is made to copy the scope file to a non-volatile media card fitted to the drive each time the post-trigger data has been acquired. The file name is SCP00XY.DAT, where XY is defined by *Scope Auto-save File Number* (09.071). If *Scope Auto-save Mode* (09.070) = 1 (Overwrite) then a file is over-written if it already exists. If *Scope Auto-save Mode* (09.070) = 2 (Keep) then if the file already exists the auto-save process is aborted. *Scope Auto-save File Number* (09.071) is incremented after a file is saved successfully and rolls over to 0 if it exceeds its maximum value.

If *Scope Auto-save Status* (09.073) = 0 (Disabled) and all the other conditions listed above for auto-saving to be active are met, then *Scope Auto-save Status* (09.073) changes to 1 (Active), so that auto-saving becomes active. If the scope file cannot be saved because the file exists and *Scope Auto-save Mode* (09.070) = 2 (Keep) then *Scope Auto-save Status* (09.073) is set to 2 (Stopped). If the scope file cannot be saved for any other reason then *Scope Auto-save Status* (09.073) is set to 3 (Failed). If *Scope Auto-save Status* (09.073) is no longer 1 (Active), auto-saving is aborted. Auto-saving can be made active again by setting *Scope Auto-save Reset* (09.072) to 1 and then to 0. If *Scope Auto-save Mode* (09.070) = 0 (Disabled) then *Scope Auto-save Status* (09.073) is set to 0 (Disabled), or if *Scope Auto-save Mode* (09.070) is non-zero then *Scope Auto-save Status* (09.073) is set to 1 (Active). It should be noted that *Scope Auto-save Status* (09.073) is a power-down save parameter, and so auto-save will remain inactive if *Scope Auto-save Status* (09.073) is 2 or 3 even if the drive is powered down and then powered up again.

Parameter	09.071 Scope Auto-save File Number		
Short description	Shows the file number to be used for the next auto-saved scope file		
Mode	Regeneration		
Minimum	0	Maximum	99
Default	0	Units	
Type	8 Bit Power Down Save	Update Rate	Background read/write
Display Format	Standard	Decimal Places	0
Coding	RO, NC		

See *Scope Auto-save Mode* (09.070).

Parameter	09.072 Scope Auto-save Reset		
Short description	Set to reset the scope auto-save function		
Mode	Regeneration		
Minimum	0	Maximum	1
Default	0	Units	
Type	1 Bit Volatile	Update Rate	Background read
Display Format	Standard	Decimal Places	0
Coding	RW		

See *Scope Auto-save Mode* (09.070).

Parameter	09.073 Scope Auto-save Status		
Short description	Shows the status of the scope auto-save function		
Mode	Regeneration		
Minimum	0	Maximum	3
Default	0	Units	
Type	8 Bit Power Down Save	Update Rate	Background write
Display Format	Standard	Decimal Places	0
Coding	RO, TE, NC		

Value	Text
0	Disabled
1	Active
2	Stopped
3	Failed

See *Scope Auto-save Mode* (09.070).

Menu 10 Single Line Descriptions – *Status and Trips*

Mode: Regeneration

Parameter		Range	Default	Type					
10.001	Drive Healthy	Off (0) or On (1)		RO	Bit	ND	NC	PT	
10.002	Drive Active	Off (0) or On (1)		RO	Bit	ND	NC	PT	
10.008	Rated Load Reached	Off (0) or On (1)		RO	Bit	ND	NC	PT	
10.009	Current Limit Active	Off (0) or On (1)		RO	Bit	ND	NC	PT	
10.010	Regenerating	Off (0) or On (1)		RO	Bit	ND	NC	PT	
10.011	Braking IGBT Active	Off (0) or On (1)		RO	Bit	ND	NC	PT	
10.012	Braking Resistor Alarm	Off (0) or On (1)		RO	Bit	ND	NC	PT	
10.015	Supply Loss	Off (0) or On (1)		RO	Bit	ND	NC	PT	
10.016	Under Voltage Active	Off (0) or On (1)		RO	Bit	ND	NC	PT	
10.017	Inductor Overload Alarm	Off (0) or On (1)		RO	Bit	ND	NC	PT	
10.018	Drive Over-temperature Alarm	Off (0) or On (1)		RO	Bit	ND	NC	PT	
10.019	Drive Warning	Off (0) or On (1)		RO	Bit	ND	NC	PT	
10.020	Trip 0	0 to 255		RO	Txt	ND	NC	PT	PS
10.021	Trip 1	0 to 255		RO	Txt	ND	NC	PT	PS
10.022	Trip 2	0 to 255		RO	Txt	ND	NC	PT	PS
10.023	Trip 3	0 to 255		RO	Txt	ND	NC	PT	PS
10.024	Trip 4	0 to 255		RO	Txt	ND	NC	PT	PS
10.025	Trip 5	0 to 255		RO	Txt	ND	NC	PT	PS
10.026	Trip 6	0 to 255		RO	Txt	ND	NC	PT	PS
10.027	Trip 7	0 to 255		RO	Txt	ND	NC	PT	PS
10.028	Trip 8	0 to 255		RO	Txt	ND	NC	PT	PS
10.029	Trip 9	0 to 255		RO	Txt	ND	NC	PT	PS
10.030	Braking Resistor Rated Power	0.000 to 99999.999 kW	0.000 kW	RW	Num				US
10.031	Braking Resistor Thermal Time Constant	0.000 to 1500.000 s	0.000 s	RW	Num				US
10.032	External Trip	Off (0) or On (1)	Off (0)	RW	Bit		NC		
10.033	Drive Reset	Off (0) or On (1)	Off (0)	RW	Bit		NC		
10.034	Number Of Auto-reset Attempts	None (0), 1 (1), 2 (2), 3 (3), 4 (4), 5 (5), Infinite (6)	None (0)	RW	Txt				US
10.035	Auto-reset Delay	1.0 to 600.0 s	1.0 s	RW	Num				US
10.036	Auto-reset Hold Drive Healthy	Off (0) or On (1)	Off (0)	RW	Bit				US
10.037	Action On Trip Detection	00000 to 11111	00000	RW	Bin				US
10.038	User Trip	0 to 255		RW	Num	ND	NC		
10.039	Braking Resistor Thermal Accumulator	0.0 to 100.0 %		RO	Num	ND	NC	PT	
10.040	Status Word	0 to 32767		RO	Num	ND	NC	PT	
10.041	Trip 0 Date	00-00-00 to 31-12-99		RO	Date	ND	NC	PT	PS
10.042	Trip 0 Time	00:00:00 to 23:59:59		RO	Time	ND	NC	PT	PS
10.043	Trip 1 Date	00-00-00 to 31-12-99		RO	Date	ND	NC	PT	PS
10.044	Trip 1 Time	00:00:00 to 23:59:59		RO	Time	ND	NC	PT	PS
10.045	Trip 2 Date	00-00-00 to 31-12-99		RO	Date	ND	NC	PT	PS
10.046	Trip 2 Time	00:00:00 to 23:59:59		RO	Time	ND	NC	PT	PS
10.047	Trip 3 Date	00-00-00 to 31-12-99		RO	Date	ND	NC	PT	PS
10.048	Trip 3 Time	00:00:00 to 23:59:59		RO	Time	ND	NC	PT	PS
10.049	Trip 4 Date	00-00-00 to 31-12-99		RO	Date	ND	NC	PT	PS
10.050	Trip 4 Time	00:00:00 to 23:59:59		RO	Time	ND	NC	PT	PS
10.051	Trip 5 Date	00-00-00 to 31-12-99		RO	Date	ND	NC	PT	PS
10.052	Trip 5 Time	00:00:00 to 23:59:59		RO	Time	ND	NC	PT	PS
10.053	Trip 6 Date	00-00-00 to 31-12-99		RO	Date	ND	NC	PT	PS
10.054	Trip 6 Time	00:00:00 to 23:59:59		RO	Time	ND	NC	PT	PS
10.055	Trip 7 Date	00-00-00 to 31-12-99		RO	Date	ND	NC	PT	PS
10.056	Trip 7 Time	00:00:00 to 23:59:59		RO	Time	ND	NC	PT	PS
10.057	Trip 8 Date	00-00-00 to 31-12-99		RO	Date	ND	NC	PT	PS
10.058	Trip 8 Time	00:00:00 to 23:59:59		RO	Time	ND	NC	PT	PS
10.059	Trip 9 Date	00-00-00 to 31-12-99		RO	Date	ND	NC	PT	PS
10.060	Trip 9 Time	00:00:00 to 23:59:59		RO	Time	ND	NC	PT	PS
10.061	Braking Resistor Resistance	0.00 to 10000.00 Ω	0.00 Ω	RW	Num				US
10.063	Local Keypad Battery Low	Off (0) or On (1)		RO	Bit	ND	NC	PT	
10.064	Remote Keypad Battery Low	Off (0) or On (1)		RO	Bit	ND	NC	PT	
10.065	Auto-tune Active	Off (0) or On (1)		RO	Bit	ND	NC	PT	
10.067	Fire Mode Active	Off (0) or On (1)		RO	Bit	ND	NC	PT	
10.068	Hold Drive Healthy on Under Voltage	Off (0) or On (1)	Off (0)	RW	Bit				US
10.069	Additional Status Bits	0 to 1023		RO	Num	ND	NC	PT	
10.070	Trip 0 Sub-trip Number	0 to 65535		RO	Num	ND	NC	PT	PS
10.071	Trip 1 Sub-trip Number	0 to 65535		RO	Num	ND	NC	PT	PS
10.072	Trip 2 Sub-trip Number	0 to 65535		RO	Num	ND	NC	PT	PS

10.073	Trip 3 Sub-trip Number	0 to 65535		RO	Num	ND	NC	PT	PS
10.074	Trip 4 Sub-trip Number	0 to 65535		RO	Num	ND	NC	PT	PS
10.075	Trip 5 Sub-trip Number	0 to 65535		RO	Num	ND	NC	PT	PS
10.076	Trip 6 Sub-trip Number	0 to 65535		RO	Num	ND	NC	PT	PS
10.077	Trip 7 Sub-trip Number	0 to 65535		RO	Num	ND	NC	PT	PS
10.078	Trip 8 Sub-trip Number	0 to 65535		RO	Num	ND	NC	PT	PS
10.079	Trip 9 Sub-trip Number	0 to 65535		RO	Num	ND	NC	PT	PS
10.081	Phase Loss	Off (0) or On (1)		RO	Bit	ND	NC	PT	
10.101	Drive Status	Inhibit (0), Ready (1), Stop (2), Scan (3), Run (4), Supply Loss (5), Deceleration (6), dc Injection (7), Position (8), Trip (9), Active (10), Off (11), Hand (12), Auto (13), Heat (14), Under Voltage (15)		RO	Txt	ND	NC	PT	
10.102	Trip Reset Source	0 to 1023		RO	Num	ND	NC	PT	PS
10.103	Trip Time Identifier	-2147483648 to 2147483647 ms		RO	Num	ND	NC	PT	
10.104	Active Alarm	None (0), Brake Resistor (1), Motor Overload (2), Ind Overload (3), Drive Overload (4), Auto Tune (5), Limit Switch (6), Fire Mode (7), Low Load (8), Option Slot 1 (9), Option Slot 2 (10), Option Slot 3 (11), Option Slot 4 (12)		RO	Txt	ND	NC	PT	
10.106	Potential Drive Damage Conditions	0000 to 1111		RO	Bin	ND	NC	PT	PS
10.107	Auto-tune State	Not Active (0), Resistance (1), pLs (2), Ls (3), Flux (4), Flux Repeat (5), Ld Lq No-load (6), Lq (7), Ke (8), Inertia (9)		RO	Txt	ND	NC	PT	

RW	Read / Write	RO	Read-only	Bit	Bit parameter	Txt	Text string	Date	Date parameter	Time	Time parameter
Chr	Character parameter	Bin	Binary parameter	IP	IP address	Mac	MAC address	Ver	Version number	SMP	Slot, menu, parameter
Num	Number parameter	DE	Destination	ND	No default value	RA	Rating dependent	NC	Non-copyable	PT	Protected
Fl	Filtered	US	User save	PS	Power-down save						

Menu 10 – Status and Trips

Mode: Regeneration

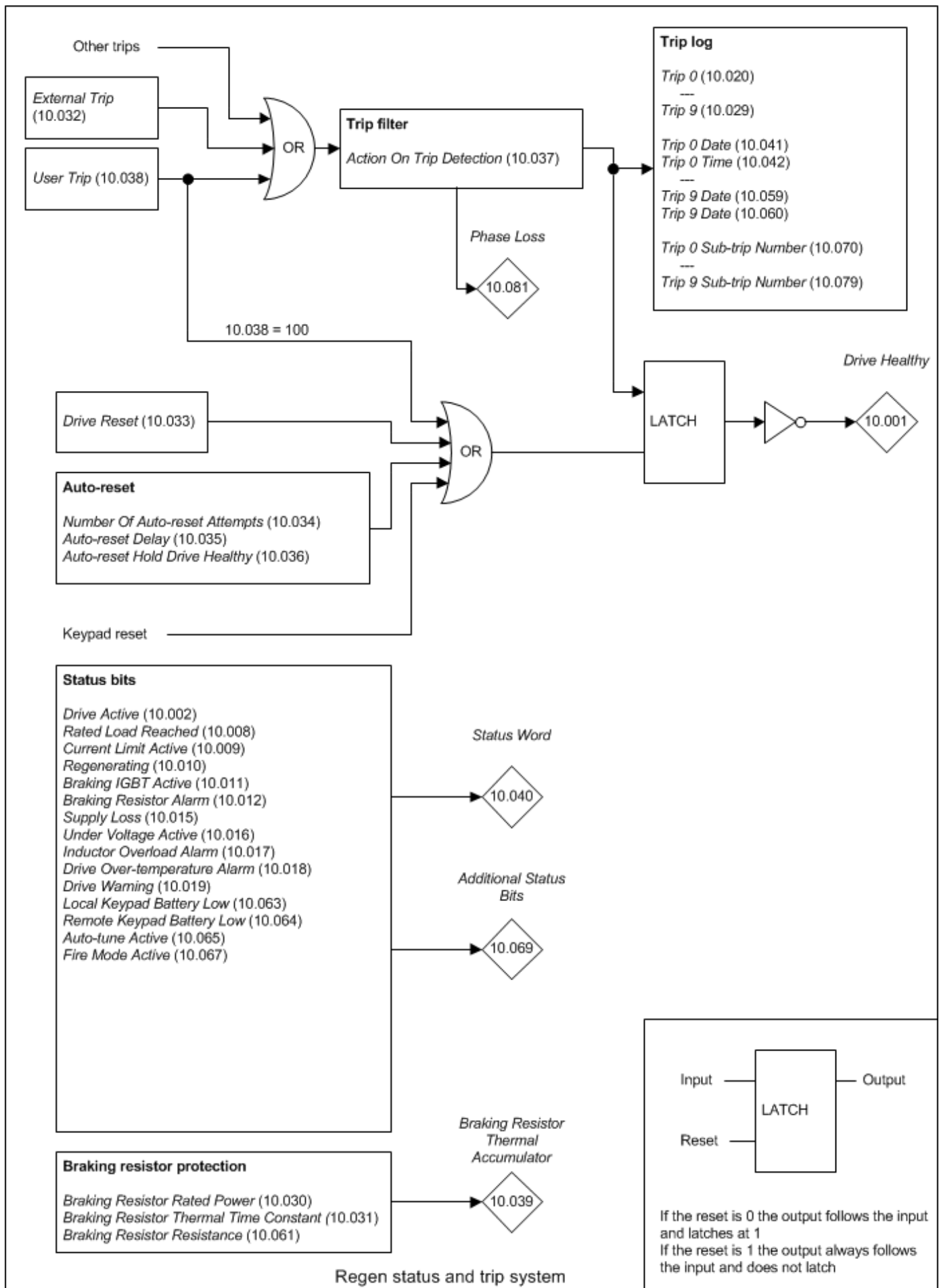

Parameter	10.001 Drive Healthy		
Short description	Indicates that the drive is healthy		
Mode	Regeneration		
Minimum	0	Maximum	1
Default		Units	
Type	1 Bit Volatile	Update Rate	Background write
Display Format	Standard	Decimal Places	0
Coding	RO, ND, NC, PT		

Drive Healthy (10.001) indicates that the drive is not in the trip or the under voltage state if it is set to one. If *Auto-reset Hold Drive Healthy* (10.036) = 1 and auto-reset is being used, *Drive Healthy* (10.001) is not cleared until all auto-resets have been attempted and the next trip occurs. The LED on the front of the drive gives an indication of the drive state as shown in the table below.

Drive State	LED
Normal power and <i>Drive Healthy</i> (10.001) = 1	On continuously
Normal power and <i>Drive Healthy</i> (10.001) = 0	Flashing: 0.5s on and 0.5s off
Standby power state	Flashing: 0.5s on and 7.5s off

Parameter	10.002 Drive Active		
Short description	Indicates that the inverter is active		
Mode	Regeneration		
Minimum	0	Maximum	1
Default		Units	
Type	1 Bit Volatile	Update Rate	2ms write
Display Format	Standard	Decimal Places	0
Coding	RO, ND, NC, PT		

If the drive inverter is active *Drive Active* (10.002) is set to one, otherwise it is zero.

Parameter	10.008 Rated Load Reached		
Short description	Indicates that the real component of the output current has reached rated current		
Mode	Regeneration		
Minimum	0	Maximum	1
Default		Units	
Type	1 Bit Volatile	Update Rate	Background write
Display Format	Standard	Decimal Places	0
Coding	RO, ND, NC, PT		

In Regen mode *Rated Load Reached* (10.008) indicates that the real component of current is at or above the *Rated Current* (05.007). This condition is also detected when the modulus of *Percentage Load* (04.020) is greater or equal to 100.0%.

Parameter	10.009 Current Limit Active		
Short description	Indicates that the current limit is active		
Mode	Regeneration		
Minimum	0	Maximum	1
Default		Units	
Type	1 Bit Volatile	Update Rate	4ms write
Display Format	Standard	Decimal Places	0
Coding	RO, ND, NC, PT		

Current Limit Active (10.009) is set to one if the current limit is active. It should be noted that the current limit system is used in RFC-A and RFC-S modes when standard ramp control is active (*Ramp Mode* (02.004)), or supply loss control is in ramp stop or limit stop mode (*Supply Loss Mode* (06.003)). Therefore *Current Limit Active* (10.009) is likely to change to one under these conditions, even if the user defined current limits are not active.

Parameter	10.010 Regenerating		
Short description	Indicates that power is being transferred from the regen drive to the supply		
Mode	Regeneration		
Minimum	0	Maximum	1
Default		Units	
Type	1 Bit Volatile	Update Rate	Background write
Display Format	Standard	Decimal Places	0
Coding	RO, ND, NC, PT		

In Regen mode *Regenerating* (10.010) is set to one if power is being transferred from the regen drive to the supply.

Parameter	10.011 <i>Braking IGBT Active</i>		
Short description	Indicates that the braking IGBT is active		
Mode	Regeneration		
Minimum	0	Maximum	1
Default		Units	
Type	1 Bit Volatile	Update Rate	Background write
Display Format	Standard	Decimal Places	0
Coding	RO, ND, NC, PT		

Braking IGBT Active (10.011) is set to one if the braking IGBT is active. As the braking IGBT active periods may be short, each time the braking IGBT is switched on *Braking IGBT Active* (10.011) is set to one and remains at one for at least 0.5s.

Parameter	10.012 <i>Braking Resistor Alarm</i>		
Short description	Indicates that the braking IGBT is active and the braking resistor thermal accumulator is greater than 75%		
Mode	Regeneration		
Minimum	0	Maximum	1
Default		Units	
Type	1 Bit Volatile	Update Rate	Background write
Display Format	Standard	Decimal Places	0
Coding	RO, ND, NC, PT		

Braking Resistor Alarm (10.012) is set when the braking IGBT is active and *Braking Resistor Thermal Accumulator* (10.039) is greater than 75.0%. As the braking IGBT on periods may be short *Braking Resistor Alarm* (10.012) is always held on for at least 0.5s.

Parameter	10.015 <i>Supply Loss</i>		
Short description	Indicates that the drive is in the supply loss state		
Mode	Regeneration		
Minimum	0	Maximum	1
Default		Units	
Type	1 Bit Volatile	Update Rate	Background write
Display Format	Standard	Decimal Places	0
Coding	RO, ND, NC, PT		

In Regen mode *Supply Loss* (10.015) always indicates that the regen drive is in the supply loss state. See *Regen Supply Loss a.c. Level* (03.023) for details.

Parameter	10.016 <i>Under Voltage Active</i>		
Short description	Indicates that the drive is in the under voltage state		
Mode	Regeneration		
Minimum	0	Maximum	1
Default		Units	
Type	1 Bit Volatile	Update Rate	4ms write
Display Format	Standard	Decimal Places	0
Coding	RO, ND, NC, PT		

Under Voltage Active (10.016) indicates that the drive is in the under voltage state. See *Standard Under Voltage Threshold* (06.065) for more details.

Parameter	10.017 <i>Inductor Overload Alarm</i>		
Short description	Indicates that the inductor overload accumulator is above 75% and the output current is high		
Mode	Regeneration		
Minimum	0	Maximum	1
Default		Units	
Type	1 Bit Volatile	Update Rate	Background write
Display Format	Standard	Decimal Places	0
Coding	RO, ND, NC, PT		

Motor Overload Alarm (10.017) is set if the drive output current is higher than the level that will eventually cause an *Motor Too Hot* trip and the *Inductor Protection Accumulator* (04.019) is higher than 75.0%. See *Inductor Thermal Time Constant* (04.015) for more details.

Parameter	10.018 <i>Drive Over-temperature Alarm</i>		
Short description	Indicates that the drive over-temperature alarm is active		
Mode	Regeneration		
Minimum	0	Maximum	1
Default		Units	
Type	1 Bit Volatile	Update Rate	Background write
Display Format	Standard	Decimal Places	0
Coding	RO, ND, NC, PT		

Drive Over-temperature Alarm (10.018) is set if *Percentage Of Drive Thermal Trip Level* (07.036) is greater than 90%.

Parameter	10.019 Drive Warning		
Short description	Indicates that one or more of the drive warning alarms are active		
Mode	Regeneration		
Minimum	0	Maximum	1
Default		Units	
Type	1 Bit Volatile	Update Rate	Background write
Display Format	Standard	Decimal Places	0
Coding	RO, ND, NC, PT		

Drive Warning (10.019) is set to one if any of the drive warnings is active, and is defined as:

Drive Warning (10.019) = *Braking Resistor Alarm* (10.012) OR *Motor Overload Alarm* (10.017) OR *Drive Over-temperature Alarm* (10.018)

Parameter	10.020 Trip 0		
Short description	Shows the current or last trip to have occurred		
Mode	Regeneration		
Minimum	0	Maximum	255
Default		Units	
Type	8 Bit Power Down Save	Update Rate	Write on trip
Display Format	Standard	Decimal Places	0
Coding	RO, TE, ND, NC, PT, BU		

[Click here to view trips in numerical order.](#)

Value	Text
28	An Input 1 Loss
29	An Input 2 Loss
219	An Output Calib
217	App Menu Changed
11	Autotune 1
12	Autotune 2
13	Autotune 3
14	Autotune 4
15	Autotune 5
16	Autotune 6
17	Autotune 7
18	Autotune Stopped
19	Brake R Too Hot
99	CAM
185	Card Access
177	Card Boot
178	Card Busy
188	Card Compare
179	Card Data Exists
187	Card Drive Mode
182	Card Error
184	Card Full
183	Card No Data
180	Card Option
175	Card Product
186	Card Rating
181	Card Read Only
174	Card Slot
102	Cloning
111	Configuration
35	Control Word
225	Current Offset
97	Data Changing
247	Derivative ID
248	Derivative Image
199	Destination
224	Drive Size
31	EEPROM Fail
189	Encoder 1
190	Encoder 2
191	Encoder 3
192	Encoder 4
193	Encoder 5
194	Encoder 6
195	Encoder 7
196	Encoder 8
197	Encoder 9
162	Encoder 12
163	Encoder 13
164	Encoder 14
6	External Trip
26	I/O Overload
8	Inductance
93	Inductor Too Hot
103	Inter-connect
160	Island
34	Keypad Mode
39	Line Sync
38	Low Load
20	Motor Too Hot
176	Name Plate
0	None
101	OHT Brake

23	Oht Control
27	Oht dc bus
21	Oht Inverter
22	Oht Power
3	OI ac
4	OI Brake
109	OI dc
92	OI Snubber
215	Option Disable
98	Out Phase Loss
7	Over Speed
2	Over Volts
32	Phase Loss
198	Phasing Error
90	Power Comms
220	Power Data
37	Power Down Save
5	PSU
9	PSU 24V
223	Rating Mismatch
94	Rectifier Set-up
1	Reserved 001
95	Reserved 095
104	Reserved 104
105	Reserved 105
106	Reserved 106
107	Reserved 107
108	Reserved 108
161	Reserved 161
165	Reserved 165
166	Reserved 166
167	Reserved 167
168	Reserved 168
170	Reserved 170
171	Reserved 171
172	Reserved 172
173	Reserved 173
222	Reserved 222
228	Reserved 228
229	Reserved 229
230	Reserved 230
231	Reserved 231
232	Reserved 232
233	Reserved 233
234	Reserved 234
235	Reserved 235
236	Reserved 236
237	Reserved 237
238	Reserved 238
239	Reserved 239
240	Reserved 240
241	Reserved 241
242	Reserved 242
243	Reserved 243
244	Reserved 244
245	Reserved 245
246	Reserved 246
100	Reset
255	Reset Logs
33	Resistance
204	Slot1 Different
202	Slot1 Error
200	Slot1 HF
203	Slot1 Not Fitted
201	Slot1 Watchdog

209	Slot2 Different
207	Slot2 Error
205	Slot2 HF
208	Slot2 Not Fitted
206	Slot2 Watchdog
214	Slot3 Different
212	Slot3 Error
210	Slot3 HF
213	Slot3 Not Fitted
211	Slot3 Watchdog
254	Slot4 Different
252	Slot4 Error
250	Slot4 HF
253	Slot4 Not Fitted
251	Slot4 Watchdog
216	Slot App Menu
226	Soft Start
221	Stored HF
227	Sub-array RAM
218	Temp Feedback
10	Th Brake Res
25	Th Short Circuit
24	Thermistor
110	Undefined
91	User 24V
96	User Prog Trip
249	User Program
36	User Save
40	User Trip 40
41	User Trip 41
42	User Trip 42
43	User Trip 43
44	User Trip 44
45	User Trip 45
46	User Trip 46
47	User Trip 47
48	User Trip 48
49	User Trip 49
50	User Trip 50
51	User Trip 51
52	User Trip 52
53	User Trip 53
54	User Trip 54
55	User Trip 55
56	User Trip 56
57	User Trip 57
58	User Trip 58
59	User Trip 59
60	User Trip 60
61	User Trip 61
62	User Trip 62
63	User Trip 63
64	User Trip 64
65	User Trip 65
66	User Trip 66
67	User Trip 67
68	User Trip 68
69	User Trip 69
70	User Trip 70
71	User Trip 71
72	User Trip 72
73	User Trip 73
74	User Trip 74
75	User Trip 75
76	User Trip 76

77	User Trip 77
78	User Trip 78
79	User Trip 79
80	User Trip 80
81	User Trip 81
82	User Trip 82
83	User Trip 83
84	User Trip 84
85	User Trip 85
86	User Trip 86
87	User Trip 87
88	User Trip 88
89	User Trip 89
112	User Trip 112
113	User Trip 113
114	User Trip 114
115	User Trip 115
116	User Trip 116
117	User Trip 117
118	User Trip 118
119	User Trip 119
120	User Trip 120
121	User Trip 121
122	User Trip 122
123	User Trip 123
124	User Trip 124
125	User Trip 125
126	User Trip 126
127	User Trip 127
128	User Trip 128
129	User Trip 129
130	User Trip 130
131	User Trip 131
132	User Trip 132
133	User Trip 133
134	User Trip 134
135	User Trip 135
136	User Trip 136
137	User Trip 137
138	User Trip 138
139	User Trip 139
140	User Trip 140
141	User Trip 141
142	User Trip 142
143	User Trip 143
144	User Trip 144
145	User Trip 145
146	User Trip 146
147	User Trip 147
148	User Trip 148
149	User Trip 149
150	User Trip 150
151	User Trip 151
152	User Trip 152
153	User Trip 153
154	User Trip 154
155	User Trip 155
156	User Trip 156
157	User Trip 157
158	User Trip 158
159	User Trip 159
169	Voltage Range
30	Watchdog

Trip 0 (10.020) to *Trip 9* (10.029) store the most recent 10 trips that have occurred where *Trip 0* (10.020) is the most recent and *Trip 9* (10.029) is the

oldest. When a new trip occurs it is written to *Trip 0* (10.020) and all the other trips move down the log, with oldest being lost. The date and time when each trip occurs are also stored in the date and time log, i.e. *Trip 0 Date* (10.041) to *Trip 9 Time* (10.060). The date and time are taken from *Date* (06.016) and *Time* (06.017). Some trips have sub-trip numbers which give more detail about the reason for the trip. If a trip has a sub-trip number its value is stored in the sub-trip log, i.e. *Trip 0 Sub-trip Number* (10.070) to *Trip 9 Sub-trip Number* (10.079). If the trip does not have a sub-trip number then zero is stored in the sub-trip log.

Trip categories and priorities

Trips are grouped into the categories given in the table below. A trip can only occur when the drive is not tripped, or if it is already tripped and the new trip has a higher priority than the active trip (i.e. lower priority number). Unless otherwise stated a trip cannot be reset until 1.0s after it has been initiated.

Priority	Category	Trips	Comments
1	Internal faults	<i>HF01 – HF20</i>	These are fatal problems that cannot be reset. All drive features are inactive after any of these trips occur. If a basic keypad is fitted it will show the trip, but the keypad will not function. These trips are not stored in the trip log.
1	Stored HF trip	<i>Stored HF</i>	This trip cannot be cleared unless 1299 is entered into <i>Parameter mm.000</i> (mm.000) and a reset is initiated.
2	Non-resettable trips	Trip numbers 218 to 247, <i>Slot1 HF</i> , <i>Slot2 HF</i> , <i>Slot3 HF</i> or <i>Slot4 HF</i>	These trips cannot be reset.
3	Volatile memory failure	<i>EEPROM Fail</i>	This can only be reset if <i>Parameter mm.000</i> (mm.000) is set to 1233 or 1244, or if <i>Load Defaults</i> (11.043) is set to a non-zero value.
4	Internal 24V power supply	<i>PSU 24V</i>	
5	Non-volatile media trips	Trip numbers 174, 175 and 177 to 188	These trips are priority 6 during power-up.
5	Position feedback interface power supply	<i>Encoder 1</i>	This trip can override <i>Encoder 2</i> to <i>Encoder 6</i> trips.
6	Trips with extended reset times	<i>OI ac</i> , <i>OI Brake</i> , and <i>OI dc</i>	These trips cannot be reset until 10s after the trip was initiated.
6	Phase loss and d.c. link power circuit protection	<i>Phase Loss</i> and <i>OHT dc bus</i>	The drive will attempt to stop the motor before tripping if a <i>Phase Loss.000</i> trip occurs unless this feature has been disabled (see <i>Action On Trip Detection</i> (10.037)). The drive will always attempt to stop the motor before tripping if an <i>OHT dc bus</i> occurs.
6	Standard trips	All other trips	

Internal faults

Trips {*HF01*} to {*HF20*} are internal faults that do not have trip numbers. If one of these trips occurs, the main drive processor has detected an irrecoverable error. All drive functions are stopped and the trip message will be displayed on the drive keypad. The error can only be reset by powering the drive down and up again. The table below gives the reasons for internal faults and their corresponding trip.

Trip	Reason
{HF01}	CPU has detected an address error
{HF02}	CPU DMAC has detected an address error
{HF03}	CPU has detected an Illegal opcode
{HF04}	CPU has detected an Illegal slot instruction
{HF05}	An interrupt has occurred that does not have a defined function (Undefined exception)
{HF06}	An interrupt has occurred which is reserved (Reserved exception)
{HF07}	Watchdog failure
{HF08}	CPU Interrupt crash
{HF09}	Free store overflow
{HF10}	Parameter routing system error
{HF11}	Non-volatile memory comms error
{HF12}	Stack overflow. Sub-trip is shown to indicate which stack: 1 – background tasks 2 – timed tasks 3 – main system interrupts
{HF13}	The control hardware is not compatible with the firmware. The sub-trip number gives the actual ID code of the control board hardware.
{HF14}	CPU register bank error
{HF15}	CPU divide error
{HF16}	RTOS error (the background task has returned)
{HF17}	The clock supplied to the control board logic is out of specification
{HF18}	The internal flash memory has failed when writing option module parameter data. Sub-trip is shown to indicate which failure: 1 - Programming error while writing menu in flash 2 - Erase flash block containing setup menus failed 3 - Erase flash block containing application menus failed
{HF19}	Invalid main application firmware CRC. Reprogramming required.
{HF20}	The ASIC is not compatible with the firmware. The sub-trip number displayed is the ASIC version.
{HF23}	If this trip occurs please consult the drive supplier.
{HF24}	If this trip occurs please consult the drive supplier.
{HF25}	If this trip occurs please consult the drive supplier.

When the drive is subsequently powered up a *Stored HF* trip is initiated where the sub-trip number is the number of the HF trip that last occurred. This trip will occur at every power-up until it is reset. The trip can only be reset by first entering 1299 into *Parameter mm.000* (mm.000). If the drive is powered up and a *Stored HF* trip occurs, *Onboard User Program: Enable* (11.047) is reset to zero to prevent the on-board user program from running. This ensures that the user program can be changed or erased in case it causes an HF trip at every power-up. Once the *Stored HF* is cleared, it is necessary to power cycle the drive or to re-download the user program to allow the program to restart.

Similar trips that can be initiated by the control system or the power system

Trips shown in the table below can be generated either from the drive control system or from the power system. The sub-trip number which is in the form *xyzz* is used to identify the source of the trip. The digits *xx* are 00 for a trip generated by the control system or the number of a power module if generated by the power system. If the drive is not a multi-power module drive then *xx* will always have a value of 1 the trip is related to the power system. The *y* digit is used to identify the location of a trip which is generated by a rectifier module connected to a power module. Where the *y* digit is relevant it will have a value of 1 or more, otherwise it will be 0. The *zz* digits give the reason for the trip and are defined in each trip description.

Over Volts	Oht dc bus
OI ac	Phase Loss
OI Brake	Power Comms
PSU	OI Snubber
Oht Inverter	Cloning
Oht Power	Temp Feedback
Oht Control	Power Data

Braking IGBT

The list below gives conditions that will disable the braking IGBT:

1. *Braking IGBT Upper Threshold* (06.074) = 0, or *Low Voltage Braking IGBT Threshold Select* (06.076) = 1 and *Low Voltage Braking IGBT Threshold* (06.075) = 0.
2. The drive is in the under-voltage state.
3. A priority 1, 2 or 3 trip is active (see *Trip 0* (10.020)).
4. One of the following trips is active or would be active if another trip is not already active: *OI Brake*, *PSU*, *Th Brake Res* or *Oht Inverter*.
5. *Percentage Of Drive Thermal Trip Level* (07.036) = 100%. This is an indication that some part of the drive is too hot and is used to indicate if an internally fitted braking resistor is too hot.
6. *Brake R Too Hot* is active or the system has been set up to disable the braking IGBT based on the braking resistor temperature and the resistor is too hot (i.e. bit 2 of *Action On Trip Detection* (10.037) is set).

Note that the braking IGBT over-current trip cannot be reset until 10s after it is initiated. This period consists of a 9s period after the trip where the braking IGBT cannot be switched on again and the *OI Brake* trip is held active and cannot be reset. This 9s period is followed by the normal 1s delay, that is present for other trips, before the trip can be reset. During this 1s period it is possible for the braking IGBT to switch on again. If the conditions

are still present that caused the trip then the trip will be initiated again with a further 9s hold-off period etc.

Parameter	10.021 Trip 1		
Short description	Shows the 2nd from last trip to have occurred		
Mode	Regeneration		
Minimum	0	Maximum	255
Default		Units	
Type	8 Bit Power Down Save	Update Rate	Write on trip
Display Format	Standard	Decimal Places	0
Coding	RO, TE, ND, NC, PT, BU		

See Trip 0 (10.020).

Parameter	10.022 Trip 2		
Short description	Shows the 3rd from last trip to have occurred		
Mode	Regeneration		
Minimum	0	Maximum	255
Default		Units	
Type	8 Bit Power Down Save	Update Rate	Write on trip
Display Format	Standard	Decimal Places	0
Coding	RO, TE, ND, NC, PT, BU		

See Trip 0 (10.020).

Parameter	10.023 Trip 3		
Short description	Shows the 4th from last trip to have occurred		
Mode	Regeneration		
Minimum	0	Maximum	255
Default		Units	
Type	8 Bit Power Down Save	Update Rate	Write on trip
Display Format	Standard	Decimal Places	0
Coding	RO, TE, ND, NC, PT, BU		

See Trip 0 (10.020).

Parameter	10.024 Trip 4		
Short description	Shows the 5th from last trip to have occurred		
Mode	Regeneration		
Minimum	0	Maximum	255
Default		Units	
Type	8 Bit Power Down Save	Update Rate	Write on trip
Display Format	Standard	Decimal Places	0
Coding	RO, TE, ND, NC, PT, BU		

See Trip 0 (10.020).

Parameter	10.025 Trip 5		
Short description	Shows the 6th from last trip to have occurred		
Mode	Regeneration		
Minimum	0	Maximum	255
Default		Units	
Type	8 Bit Power Down Save	Update Rate	Write on trip
Display Format	Standard	Decimal Places	0
Coding	RO, TE, ND, NC, PT, BU		

See Trip 0 (10.020).

Parameter	10.026 Trip 6		
Short description	Shows the 7th from last trip to have occurred		
Mode	Regeneration		
Minimum	0	Maximum	255
Default		Units	
Type	8 Bit Power Down Save	Update Rate	Write on trip
Display Format	Standard	Decimal Places	0
Coding	RO, TE, ND, NC, PT, BU		

See Trip 0 (10.020).

Parameter	10.027 Trip 7		
Short description	Shows the 8th from last trip to have occurred		
Mode	Regeneration		
Minimum	0	Maximum	255
Default		Units	
Type	8 Bit Power Down Save	Update Rate	Write on trip
Display Format	Standard	Decimal Places	0
Coding	RO, TE, ND, NC, PT, BU		

See *Trip 0* (10.020).

Parameter	10.028 Trip 8		
Short description	Shows the 9th from last trip to have occurred		
Mode	Regeneration		
Minimum	0	Maximum	255
Default		Units	
Type	8 Bit Power Down Save	Update Rate	Write on trip
Display Format	Standard	Decimal Places	0
Coding	RO, TE, ND, NC, PT, BU		

See *Trip 0* (10.020).

Parameter	10.029 Trip 9		
Short description	Shows the 10th from last trip to have occurred		
Mode	Regeneration		
Minimum	0	Maximum	255
Default		Units	
Type	8 Bit Power Down Save	Update Rate	Write on trip
Display Format	Standard	Decimal Places	0
Coding	RO, TE, ND, NC, PT, BU		

See *Trip 0* (10.020).

Parameter	10.030 Braking Resistor Rated Power		
Short description	Set to the rated power of the braking resistor		
Mode	Regeneration		
Minimum	0.000	Maximum	99999.999
Default	0.000	Units	kW
Type	32 Bit User Save	Update Rate	Background read
Display Format	Standard	Decimal Places	3
Coding	RW		

A thermal protection system is provided for the braking resistor. If *Braking Resistor Rated Power* (10.030) is set to zero this protection system is disabled and the *Braking Resistor Thermal Accumulator* (10.039) is held at zero. If braking resistor thermal protection is required the *Braking Resistor Rated Power* (10.030), *Braking Resistor Thermal Time Constant* (10.031) and *Braking Resistor Resistance* (10.061) should be set up with the braking resistor parameters. The thermal time constant of the resistor can be calculated from the single pulse energy rating (E) and continuous power rating (P) of the resistor.

$$\text{Braking Resistor Thermal Time Constant (10.031)} = \tau = E / P$$

The braking resistor is protected with a single time constant model as shown below.

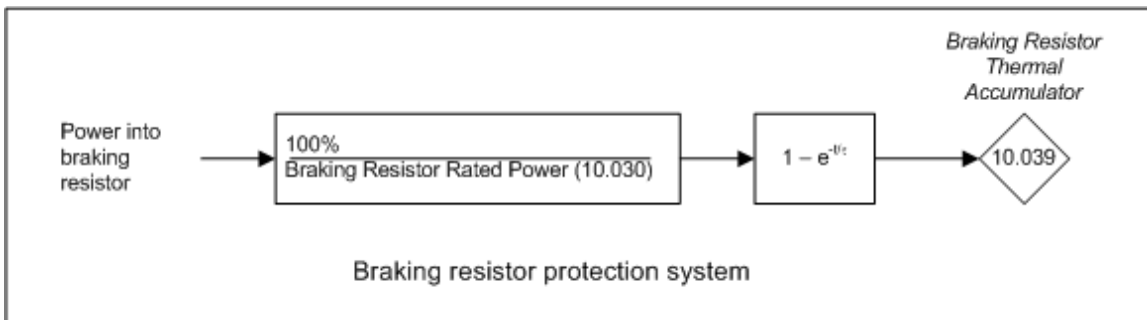

The drive monitors the power flowing into the braking resistor and updates the *Braking Resistor Thermal Accumulator* (10.039). If bit 1 of *Action On Trip Detection* (10.037) = 0 and the accumulator reaches 100% an *Brake R Too Hot* trip is initiated. If bit 1 of *Action On Trip Detection* (10.037) = 1 and the accumulator reaches 100% the braking IGBT is disabled until the accumulator falls below 95.0%.

Parameter	10.031 <i>Braking Resistor Thermal Time Constant</i>		
Short description	Set to the thermal time constant of the braking resistor		
Mode	Regeneration		
Minimum	0.000	Maximum	1500.000
Default	0.000	Units	s
Type	32 Bit User Save	Update Rate	Background read
Display Format	Standard	Decimal Places	3
Coding	RW		

See *Braking Resistor Rated Power* (10.030).

Parameter	10.032 <i>External Trip</i>		
Short description	Set to initiate an external trip		
Mode	Regeneration		
Minimum	0	Maximum	1
Default	0	Units	
Type	1 Bit Volatile	Update Rate	Background read
Display Format	Standard	Decimal Places	0
Coding	RW, NC		

If *External Trip* (10.032) is set to one an *External Trip.003* is initiated. A digital input can be routed to *External Trip* (10.032) to provide an external trip input function.

Parameter	10.033 <i>Drive Reset</i>		
Short description	Set to initiate a drive reset		
Mode	Regeneration		
Minimum	0	Maximum	1
Default	0	Units	
Type	1 Bit Volatile	Update Rate	Background read
Display Format	Standard	Decimal Places	0
Coding	RW, NC		

A 0 to 1 transition in *Drive Reset* (10.033) causes a drive reset. If a drive reset terminal is required a digital input should be routed to *Drive Reset* (10.033).

Parameter	10.034 <i>Number Of Auto-reset Attempts</i>		
Short description	Set to the number of required auto-reset attempts		
Mode	Regeneration		
Minimum	0	Maximum	6
Default	0	Units	
Type	8 Bit User Save	Update Rate	Background read
Display Format	Standard	Decimal Places	0
Coding	RW, TE, BU		

Value	Text
0	None
1	1
2	2
3	3
4	4
5	5
6	Infinite

If *Number Of Auto-reset Attempts* (10.034) = 0 then no auto-reset attempts are made. Any other value will cause the drive to automatically reset following a trip for the number of times programmed after a delay defined by *Auto-reset Delay* (10.035) subject to the minimum reset time allowed for the type of trip. Note that for some trips the minimum is 10s. The auto-reset count is only incremented when the trip is the same as the previous trip otherwise it is reset to 0. When the auto-reset count reaches the programmed value, any further trip of the same value will not cause an auto-reset. If the number of auto-reset attempts defined by *Number Of Auto-reset Attempts* (10.034) has not been reached and there has been no trip for 5 minutes then the auto-reset count is cleared. Auto reset will not occur after any trips with priority levels 1, 2 or 3 as defined in *Trip 0* (10.020). When a manual reset occurs the auto-reset counter is reset to zero.

If *Number Of Auto-reset Attempts* (10.034) = 6 the auto-reset counter is held at zero, and so there is no limit on the number of auto-reset attempts.

Parameter	10.035 Auto-reset Delay		
Short description	Set to the required auto-reset delay		
Mode	Regeneration		
Minimum	1.0	Maximum	600.0
Default	1.0	Units	s
Type	16 Bit User Save	Update Rate	Background read
Display Format	Standard	Decimal Places	1
Coding	RW, BU		

See *Number Of Auto-reset Attempts* (10.034).

Parameter	10.036 Auto-reset Hold Drive Healthy		
Short description	Set to hold drive healthy if further auto-reset attempts are possible		
Mode	Regeneration		
Minimum	0	Maximum	1
Default	0	Units	
Type	1 Bit User Save	Update Rate	Background read
Display Format	Standard	Decimal Places	0
Coding	RW		

If *Auto-reset Hold Drive Healthy* (10.036) = 0 then *Drive Healthy* (10.001) is cleared every time the drive trips regardless of any auto-reset that may occur. If *Auto-reset Hold Drive Healthy* (10.036) = 1 then *Drive Healthy* (10.001) is not cleared on a trip if any further auto-reset attempts are possible. Note that if the under voltage state becomes active *Drive Healthy* (10.001) will be set to zero unless *Hold Drive Healthy on Under Voltage* (10.068) = 1.

Parameter	10.037 Action On Trip Detection		
Short description	Defines the action of the drive on detection of a trip		
Mode	Regeneration		
Minimum	0 (Display: 00000)	Maximum	31 (Display: 11111)
Default	0 (Display: 00000)	Units	
Type	8 Bit User Save	Update Rate	Background read
Display Format	Binary	Decimal Places	0
Coding	RW, BU		

The bits in *Action On Trip Detection* (10.037) are defined as follows:

Bit 0: Stop on defined non-important trips

If bit 0 is set to one the drive will attempt to stop before tripping if any of the following trip conditions are detected: *I/O Overload*, *An Input 1 Loss*, *An Input 2 Loss* or *Keypad Mode*. (This bit has no effect in Regen mode.)

Bit 1: Disable braking resistor overload detection

See *Braking Resistor Rated Power* (10.030).

Bit 2: Disable phase loss stop

Normally the drive will stop when the input phase loss condition is detected. If this bit is set to 1 the drive will continue to run and will only trip when the drive is brought to a stop by the user. (This bit has no effect in Regen mode.)

Bit 3: Not Used

Bit 4: Disable parameter freeze on trip

If this bit is 0 then the parameters listed below are frozen on trip until the trip is cleared. If this bit is 1 then this feature is disabled.

Open-loop mode	RFC-A or RFC-S modes	Regen
<i>Reference Selected</i> (01.001)	<i>Reference Selected</i> (01.001)	
<i>Pre-skip Filter Reference</i> (01.002)	<i>Pre-skip Filter Reference</i> (01.002)	
<i>Pre-ramp Reference</i> (01.003)	<i>Pre-ramp Reference</i> (01.003)	
<i>Post Ramp Reference</i> (02.001)	<i>Post Ramp Reference</i> (02.001)	
<i>Frequency Slaving Demand</i> (03.001)	<i>Final Speed Reference</i> (03.001)	<i>Reactive Power</i> (03.001)
	<i>Speed Feedback</i> (03.002)	
	<i>Speed Error</i> (03.003)	
	<i>Speed Controller Output</i> (03.004)	
<i>Current Magnitude</i> (04.001)	<i>Current Magnitude</i> (04.001)	<i>Current Magnitude</i> (04.001)
<i>Iq, Torque Producing Current</i> (04.002)	<i>Iq, Torque Producing Current</i> (04.002)	<i>Active Current</i> (04.002)
<i>Id, Magnetising Current</i> (04.017)	<i>Id, Magnetising Current</i> (04.017)	<i>Reactive Current</i> (04.017)
<i>Output Frequency</i> (05.001)	<i>Output Frequency</i> (05.001)	<i>Output Frequency</i> (05.001)
<i>Output Voltage</i> (05.002)	<i>Output Voltage</i> (05.002)	<i>Output Voltage</i> (05.002)
<i>Output Power</i> (05.003)	<i>Output Power</i> (05.003)	<i>Output Power</i> (05.003)
<i>D.c. Bus Voltage</i> (05.005)	<i>D.c. Bus Voltage</i> (05.005)	<i>D.c. Bus Voltage</i> (05.005)
<i>Analog Input 1</i> (07.001)	<i>Analog Input 1</i> (07.001)	<i>Analog Input 1</i> (07.001)
<i>Analog Input 2</i> (07.002)	<i>Analog Input 2</i> (07.002)	<i>Analog Input 2</i> (07.002)
<i>Analog Input 3</i> (07.003)	<i>Analog Input 3</i> (07.003)	<i>Analog Input 3</i> (07.003)

Parameter	10.038 <i>User Trip</i>		
Short description	Can be used to generate a trip on the drive		
Mode	Regeneration		
Minimum	0	Maximum	255
Default		Units	
Type	8 Bit Volatile	Update Rate	Background read
Display Format	Standard	Decimal Places	0
Coding	RW, ND, NC, BU		

When a value other than zero is written to the *User Trip* (10.038) the actions described in the following table are performed. The drive immediately writes the value back to zero. If the value is not included in the table, then the action is the same as if the trip with the same number (with sub-trip zero) occurred provided the drive is not already tripped.

Action	<i>User Trip</i> (10.038)
No action	Numbers corresponding to priority 1, 2 or 3 trips.
Drive reset	100
Clear trip logs (parameters 10.020 to 10.029, 10.041 to 10.060 and 10.070 to 10.079)	255

Parameter	10.039 <i>Braking Resistor Thermal Accumulator</i>		
Short description	Shows the level of the braking resistor thermal accumulator		
Mode	Regeneration		
Minimum	0.0	Maximum	100.0
Default		Units	%
Type	16 Bit Volatile	Update Rate	Background write
Display Format	Standard	Decimal Places	1
Coding	RO, ND, NC, PT, BU		

See *Braking Resistor Rated Power* (10.030).

Parameter	10.040 <i>Status Word</i>		
Short description	Shows the status word for the drive		
Mode	Regeneration		
Minimum	0	Maximum	32767
Default		Units	
Type	16 Bit Volatile	Update Rate	Background write
Display Format	Standard	Decimal Places	0
Coding	RO, ND, NC, PT, BU		

The bits in *Status Word* (10.040) mirror the status bit parameters as shown below. Where the parameters do not exist in any mode the bit remains at zero.

Bit	Status parameter
0	<i>Drive Healthy</i> (10.001)
1	<i>Drive Active</i> (10.002)
2	<i>Zero Speed</i> (10.003)
3	<i>Running At Or Below Minimum Speed</i> (10.004)
4	<i>Below Set Speed</i> (10.005)
5	<i>At Speed</i> (10.006)
6	<i>Above Set Speed</i> (10.007)
7	<i>Rated Load Reached</i> (10.008)
8	<i>Current Limit Active</i> (10.009)
9	<i>Regenerating</i> (10.010)
10	<i>Braking IGBT Active</i> (10.011)
11	<i>Braking Resistor Alarm</i> (10.012)
12	<i>Reverse Direction Commanded</i> (10.013)
13	<i>Reverse Direction Running</i> (10.014)
14	<i>Supply Loss</i> (10.015)

Parameter	10.041 Trip 0 Date		
Short description	Shows the date at which trip 0 occurred		
Mode	Regeneration		
Minimum	0 (Display: 00-00-00)	Maximum	311299 (Display: 31-12-99)
Default		Units	
Type	32 Bit Power Down Save	Update Rate	Write on trip
Display Format	Date	Decimal Places	0
Coding	RO, ND, NC, PT		

See *Trip 0* (10.020).

Parameter	10.042 Trip 0 Time		
Short description	Shows the time at which trip 0 occurred		
Mode	Regeneration		
Minimum	0 (Display: 00:00:00)	Maximum	235959 (Display: 23:59:59)
Default		Units	
Type	32 Bit Power Down Save	Update Rate	Write on trip
Display Format	Time	Decimal Places	0
Coding	RO, ND, NC, PT		

See *Trip 0* (10.020).

Parameter	10.043 Trip 1 Date		
Short description	Shows the date at which trip 1 occurred		
Mode	Regeneration		
Minimum	0 (Display: 00-00-00)	Maximum	311299 (Display: 31-12-99)
Default		Units	
Type	32 Bit Power Down Save	Update Rate	Write on trip
Display Format	Date	Decimal Places	0
Coding	RO, ND, NC, PT		

See *Trip 0* (10.020).

Parameter	10.044 Trip 1 Time		
Short description	Shows the time at which trip 1 occurred		
Mode	Regeneration		
Minimum	0 (Display: 00:00:00)	Maximum	235959 (Display: 23:59:59)
Default		Units	
Type	32 Bit Power Down Save	Update Rate	Write on trip
Display Format	Time	Decimal Places	0
Coding	RO, ND, NC, PT		

See *Trip 0* (10.020).

Parameter	10.045 Trip 2 Date		
Short description	Shows the date at which trip 2 occurred		
Mode	Regeneration		
Minimum	0 (Display: 00-00-00)	Maximum	311299 (Display: 31-12-99)
Default		Units	
Type	32 Bit Power Down Save	Update Rate	Write on trip
Display Format	Date	Decimal Places	0
Coding	RO, ND, NC, PT		

See *Trip 0* (10.020).

Parameter	10.046 Trip 2 Time		
Short description	Shows the time at which trip 2 occurred		
Mode	Regeneration		
Minimum	0 (Display: 00:00:00)	Maximum	235959 (Display: 23:59:59)
Default		Units	
Type	32 Bit Power Down Save	Update Rate	Write on trip
Display Format	Time	Decimal Places	0
Coding	RO, ND, NC, PT		

See *Trip 0* (10.020).

Parameter	10.047 Trip 3 Date		
Short description	Shows the date at which trip 3 occurred		
Mode	Regeneration		
Minimum	0 (Display: 00-00-00)	Maximum	311299 (Display: 31-12-99)
Default		Units	
Type	32 Bit Power Down Save	Update Rate	Write on trip
Display Format	Date	Decimal Places	0
Coding	RO, ND, NC, PT		

See *Trip 0* (10.020).

Parameter	10.048 Trip 3 Time		
Short description	Shows the time at which trip 3 occurred		
Mode	Regeneration		
Minimum	0 (Display: 00:00:00)	Maximum	235959 (Display: 23:59:59)
Default		Units	
Type	32 Bit Power Down Save	Update Rate	Write on trip
Display Format	Time	Decimal Places	0
Coding	RO, ND, NC, PT		

See *Trip 0* (10.020).

Parameter	10.049 Trip 4 Date		
Short description	Shows the date at which trip 4 occurred		
Mode	Regeneration		
Minimum	0 (Display: 00-00-00)	Maximum	311299 (Display: 31-12-99)
Default		Units	
Type	32 Bit Power Down Save	Update Rate	Write on trip
Display Format	Date	Decimal Places	0
Coding	RO, ND, NC, PT		

See *Trip 0* (10.020).

Parameter	10.050 Trip 4 Time		
Short description	Shows the time at which trip 4 occurred		
Mode	Regeneration		
Minimum	0 (Display: 00:00:00)	Maximum	235959 (Display: 23:59:59)
Default		Units	
Type	32 Bit Power Down Save	Update Rate	Write on trip
Display Format	Time	Decimal Places	0
Coding	RO, ND, NC, PT		

See *Trip 0* (10.020).

Parameter	10.051 Trip 5 Date		
Short description	Shows the date at which trip 5 occurred		
Mode	Regeneration		
Minimum	0 (Display: 00-00-00)	Maximum	311299 (Display: 31-12-99)
Default		Units	
Type	32 Bit Power Down Save	Update Rate	Write on trip
Display Format	Date	Decimal Places	0
Coding	RO, ND, NC, PT		

See *Trip 0* (10.020).

Parameter	10.052 Trip 5 Time		
Short description	Shows the time at which trip 5 occurred		
Mode	Regeneration		
Minimum	0 (Display: 00:00:00)	Maximum	235959 (Display: 23:59:59)
Default		Units	
Type	32 Bit Power Down Save	Update Rate	Write on trip
Display Format	Time	Decimal Places	0
Coding	RO, ND, NC, PT		

See *Trip 0* (10.020).

Parameter	10.053 Trip 6 Date		
Short description	Shows the date at which trip 6 occurred		
Mode	Regeneration		
Minimum	0 (Display: 00-00-00)	Maximum	311299 (Display: 31-12-99)
Default		Units	
Type	32 Bit Power Down Save	Update Rate	Write on trip
Display Format	Date	Decimal Places	0
Coding	RO, ND, NC, PT		

See *Trip 0* (10.020).

Parameter	10.054 Trip 6 Time		
Short description	Shows the time at which trip 6 occurred		
Mode	Regeneration		
Minimum	0 (Display: 00:00:00)	Maximum	235959 (Display: 23:59:59)
Default		Units	
Type	32 Bit Power Down Save	Update Rate	Write on trip
Display Format	Time	Decimal Places	0
Coding	RO, ND, NC, PT		

See *Trip 0* (10.020).

Parameter	10.055 Trip 7 Date		
Short description	Shows the date at which trip 7 occurred		
Mode	Regeneration		
Minimum	0 (Display: 00-00-00)	Maximum	311299 (Display: 31-12-99)
Default		Units	
Type	32 Bit Power Down Save	Update Rate	Write on trip
Display Format	Date	Decimal Places	0
Coding	RO, ND, NC, PT		

See *Trip 0* (10.020).

Parameter	10.056 Trip 7 Time		
Short description	Shows the time at which trip 7 occurred		
Mode	Regeneration		
Minimum	0 (Display: 00:00:00)	Maximum	235959 (Display: 23:59:59)
Default		Units	
Type	32 Bit Power Down Save	Update Rate	Write on trip
Display Format	Time	Decimal Places	0
Coding	RO, ND, NC, PT		

See *Trip 0* (10.020).

Parameter	10.057 Trip 8 Date		
Short description	Shows the date at which trip 8 occurred		
Mode	Regeneration		
Minimum	0 (Display: 00-00-00)	Maximum	311299 (Display: 31-12-99)
Default		Units	
Type	32 Bit Power Down Save	Update Rate	Write on trip
Display Format	Date	Decimal Places	0
Coding	RO, ND, NC, PT		

See *Trip 0* (10.020).

Parameter	10.058 Trip 8 Time		
Short description	Shows the time at which trip 8 occurred		
Mode	Regeneration		
Minimum	0 (Display: 00:00:00)	Maximum	235959 (Display: 23:59:59)
Default		Units	
Type	32 Bit Power Down Save	Update Rate	Write on trip
Display Format	Time	Decimal Places	0
Coding	RO, ND, NC, PT		

See *Trip 0* (10.020).

Parameter	10.059 Trip 9 Date		
Short description	Shows the date at which trip 9 occurred		
Mode	Regeneration		
Minimum	0 (Display: 00-00-00)	Maximum	311299 (Display: 31-12-99)
Default		Units	
Type	32 Bit Power Down Save	Update Rate	Write on trip
Display Format	Date	Decimal Places	0
Coding	RO, ND, NC, PT		

See *Trip 0* (10.020).

Parameter	10.060 Trip 9 Time		
Short description	Shows the time at which trip 9 occurred		
Mode	Regeneration		
Minimum	0 (Display: 00:00:00)	Maximum	235959 (Display: 23:59:59)
Default		Units	
Type	32 Bit Power Down Save	Update Rate	Write on trip
Display Format	Time	Decimal Places	0
Coding	RO, ND, NC, PT		

See *Trip 0* (10.020).

Parameter	10.061 Braking Resistor Resistance		
Short description	Set the resistance value of the braking resistor		
Mode	Regeneration		
Minimum	0.00	Maximum	10000.00
Default	0.00	Units	Ω
Type	32 Bit User Save	Update Rate	Background read
Display Format	Standard	Decimal Places	2
Coding	RW		

See *Braking Resistor Rated Power* (10.030).

Parameter	10.063 Local Keypad Battery Low		
Short description	Indicates that the real time clock battery in the local keypad is low		
Mode	Regeneration		
Minimum	0	Maximum	1
Default		Units	
Type	1 Bit Volatile	Update Rate	Background write
Display Format	Standard	Decimal Places	0
Coding	RO, ND, NC, PT		

Local Keypad Battery Low (10.063) is set to one when a keypad is fitted to the front of the drive with an internal real-time clock and the battery is not fitted or the voltage is below the minimum threshold.

Parameter	10.064 Remote Keypad Battery Low		
Short description	Indicates that the real time clock battery in the remote keypad is low		
Mode	Regeneration		
Minimum	0	Maximum	1
Default		Units	
Type	1 Bit Volatile	Update Rate	Background write
Display Format	Standard	Decimal Places	0
Coding	RO, ND, NC, PT		

Remote Keypad Battery Low (10.064) is set to one when a keypad is connected to the drive user comms port with an internal real-time clock and the battery is not fitted or the voltage is below the minimum threshold.

Parameter	10.065 <i>Auto-tune Active</i>		
Short description	Indicates that an auto-tune sequence is active		
Mode	Regeneration		
Minimum	0	Maximum	1
Default		Units	
Type	1 Bit Volatile	Update Rate	Background write
Display Format	Standard	Decimal Places	0
Coding	RO, ND, NC, PT		

Auto-tune Active (10.065) is set to one while an auto-tune sequence is active.

Parameter	10.067 <i>Fire Mode Active</i>		
Short description	Indicates that fire mode is enabled and active		
Mode	Regeneration		
Minimum	0	Maximum	1
Default		Units	
Type	1 Bit Volatile	Update Rate	Background write
Display Format	Standard	Decimal Places	0
Coding	RO, ND, NC, PT		

Fire Mode Active (10.067) is set to one when fire mode is enabled and active.

Parameter	10.068 <i>Hold Drive Healthy on Under Voltage</i>		
Short description	Set to hold drive healthy if the drive is in the under voltage state		
Mode	Regeneration		
Minimum	0	Maximum	1
Default	0	Units	
Type	1 Bit User Save	Update Rate	Background read
Display Format	Standard	Decimal Places	0
Coding	RW		

Hold Drive Healthy on Under Voltage (10.068) can be used to hold the drive healthy active (*Drive Healthy* (10.001) = 1 and not flash the status LED on the front of the drive) when the drive is in the under voltage state (*Under Voltage Active* (10.016) = 1).

If *Hold Drive Healthy on Under Voltage* (10.068) = 0 and *Under Voltage Active* (10.016) = 1, then *Drive Healthy* (10.001) will be set to 0 and the status LED on the front of the drive will flash.

If *Hold Drive Healthy on Under Voltage* (10.068) = 1, *Under Voltage Active* (10.016) = 1 and the drive is not tripped (i.e. *Drive Status* (10.101) does not equal 9), then *Drive Healthy* (10.001) will be set to 1 and the status LED on the front of the drive will not flash.

If the drive is tripped then *Drive Healthy* (10.001) will be set to 0 and the status LED will flash independent of what *Hold Drive Healthy on Under Voltage* (10.068) is set to.

Parameter	10.069 <i>Additional Status Bits</i>		
Short description	Shows the additional status bits for the drive		
Mode	Regeneration		
Minimum	0	Maximum	1023
Default		Units	
Type	16 Bit Volatile	Update Rate	Background write
Display Format	Standard	Decimal Places	0
Coding	RO, ND, NC, PT, BU		

The bits in *Additional Status Bits* (10.069) mirror the status bits parameters as shown below. Where the parameters do not exist in any mode the bit remains at zero.

Bit	Status parameter
0	<i>Under Voltage Active</i> (10.016)
1	<i>Motor Overload Alarm</i> (10.017) or <i>Inductor Overload Alarm</i> (10.017)
2	<i>Drive Over-temperature Alarm</i> (10.018)
3	<i>Drive Warning</i> (10.019)
4	<i>Low Load Detected Alarm</i> (10.062)
5	<i>Local Keypad Battery Low</i> (10.063)
6	<i>Remote Keypad Battery Low</i> (10.064)
7	<i>Auto-tune Active</i> (10.065)
8	<i>Limit Switch Active</i> (10.066)
9	<i>Fire Mode Active</i> (10.067)

Parameter	10.070 Trip 0 Sub-trip Number		
Short description	Shows the sub-trip number for trip 0		
Mode	Regeneration		
Minimum	0	Maximum	65535
Default		Units	
Type	16 Bit Power Down Save	Update Rate	Write on trip
Display Format	Standard	Decimal Places	0
Coding	RO, ND, NC, PT, BU		

See *Trip 0* (10.020).

Parameter	10.071 Trip 1 Sub-trip Number		
Short description	Shows the sub-trip number for trip 1		
Mode	Regeneration		
Minimum	0	Maximum	65535
Default		Units	
Type	16 Bit Power Down Save	Update Rate	Write on trip
Display Format	Standard	Decimal Places	0
Coding	RO, ND, NC, PT, BU		

See *Trip 0* (10.020).

Parameter	10.072 Trip 2 Sub-trip Number		
Short description	Shows the sub-trip number for trip 2		
Mode	Regeneration		
Minimum	0	Maximum	65535
Default		Units	
Type	16 Bit Power Down Save	Update Rate	Write on trip
Display Format	Standard	Decimal Places	0
Coding	RO, ND, NC, PT, BU		

See *Trip 0* (10.020).

Parameter	10.073 Trip 3 Sub-trip Number		
Short description	Shows the sub-trip number for trip 3		
Mode	Regeneration		
Minimum	0	Maximum	65535
Default		Units	
Type	16 Bit Power Down Save	Update Rate	Write on trip
Display Format	Standard	Decimal Places	0
Coding	RO, ND, NC, PT, BU		

See *Trip 0* (10.020).

Parameter	10.074 Trip 4 Sub-trip Number		
Short description	Shows the sub-trip number for trip 4		
Mode	Regeneration		
Minimum	0	Maximum	65535
Default		Units	
Type	16 Bit Power Down Save	Update Rate	Write on trip
Display Format	Standard	Decimal Places	0
Coding	RO, ND, NC, PT, BU		

See *Trip 0* (10.020).

Parameter	10.075 Trip 5 Sub-trip Number		
Short description	Shows the sub-trip number for trip 5		
Mode	Regeneration		
Minimum	0	Maximum	65535
Default		Units	
Type	16 Bit Power Down Save	Update Rate	Write on trip
Display Format	Standard	Decimal Places	0
Coding	RO, ND, NC, PT, BU		

See *Trip 0* (10.020).

Parameter	10.076 Trip 6 Sub-trip Number		
Short description	Shows the sub-trip number for trip 6		
Mode	Regeneration		
Minimum	0	Maximum	65535
Default		Units	
Type	16 Bit Power Down Save	Update Rate	Write on trip
Display Format	Standard	Decimal Places	0
Coding	RO, ND, NC, PT, BU		

See *Trip 0* (10.020).

Parameter	10.077 Trip 7 Sub-trip Number		
Short description	Shows the sub-trip number for trip 7		
Mode	Regeneration		
Minimum	0	Maximum	65535
Default		Units	
Type	16 Bit Power Down Save	Update Rate	Write on trip
Display Format	Standard	Decimal Places	0
Coding	RO, ND, NC, PT, BU		

See *Trip 0* (10.020).

Parameter	10.078 Trip 8 Sub-trip Number		
Short description	Shows the sub-trip number for trip 8		
Mode	Regeneration		
Minimum	0	Maximum	65535
Default		Units	
Type	16 Bit Power Down Save	Update Rate	Write on trip
Display Format	Standard	Decimal Places	0
Coding	RO, ND, NC, PT, BU		

See *Trip 0* (10.020).

Parameter	10.079 Trip 9 Sub-trip Number		
Short description	Shows the sub-trip number for trip 9		
Mode	Regeneration		
Minimum	0	Maximum	65535
Default		Units	
Type	16 Bit Power Down Save	Update Rate	Write on trip
Display Format	Standard	Decimal Places	0
Coding	RO, ND, NC, PT, BU		

See *Trip 0* (10.020).

Parameter	10.081 Phase Loss		
Short description	Indicates that an input phase has been lost		
Mode	Regeneration		
Minimum	0	Maximum	1
Default		Units	
Type	1 Bit Volatile	Update Rate	Background write
Display Format	Standard	Decimal Places	0
Coding	RO, ND, NC, PT		

If a supply phase is disconnected, or two phases are shorted together, the negative phase sequence component of supply voltage (*Negative Phase Sequence Volts* (03.038)) increases significantly. *Phase Loss* (10.081) gives an indication of either of these conditions, or a high level of supply imbalance. If *Harmonic Reduction Enable* (03.021) > 0 then this parameter is set to one if *Negative Phase Sequence Volts* (03.038) > *Positive Phase Sequence Volts* (03.037) / 2 for more than 100ms. It should be noted that *Phase Loss* (10.081) is only set when the regen drive is active, so if the transient caused by an asymmetrical fault causes the system to trip then *Phase Loss* (10.081) is not set.

Parameter	10.101 Drive Status		
Short description	Shows the present status of the drive		
Mode	Regeneration		
Minimum	0	Maximum	15
Default		Units	
Type	8 Bit Volatile	Update Rate	Background write
Display Format	Standard	Decimal Places	0
Coding	RO, TE, ND, NC, PT, BU		

Value	Text
0	Inhibit
1	Ready
2	Stop
3	Scan
4	Run
5	Supply Loss
6	Deceleration
7	dc Injection
8	Position
9	Trip
10	Active
11	Off
12	Hand
13	Auto
14	Heat
15	Under Voltage

Drive Status (10.101) shows the present status of the drive. The strings from this parameter are also used by the basic keypad to provide the status display text.

Parameter	10.102 Trip Reset Source		
Short description	Indicates whether a trip in the trip log has been reset.		
Mode	Regeneration		
Minimum	0	Maximum	1023
Default		Units	
Type	16 Bit Power Down Save	Update Rate	Write on trip
Display Format	Standard	Decimal Places	0
Coding	RO, ND, NC, PT, BU		

The bits in *Trip Reset Source* (10.102) correspond to each of the trips in the trip log (i.e. bit 0 corresponds to trip 0, bit 1 corresponds to trip 1, etc.). When a trip occurs, bit 0 is set to one and the other bits corresponding to the trips already in the trip log are shifted left one bit. If the trip is reset then bit 0 is set back to zero, otherwise if a higher priority trip occurs bit 0 is shifted left by one bit. The result is that each of the bits in *Trip Reset Source* (10.102) show whether trips in the trip log were reset or moved up the trip log by a higher priority trip.

Parameter	10.103 Trip Time Identifier		
Short description	Shows time in milliseconds since the drive powered up when a trip occurred		
Mode	Regeneration		
Minimum	-2147483648	Maximum	2147483647
Default		Units	ms
Type	32 Bit Volatile	Update Rate	Write on trip
Display Format	Standard	Decimal Places	0
Coding	RO, ND, NC, PT		

When a trip occurs the time in milliseconds since the drive powered up is stored in *Trip Time Identifier* (10.103). The time rolls-over when it reaches $2^{31} - 1$, but if the time is 0 a value of 1 is written. *Trip Time Identifier* (10.103) can be used to determine when a new trip has occurred as the value will change (unless there were exactly 2^{32} ms between trips) and will be non-zero.

Parameter	10.104 Active Alarm		
Short description	Shows the value of the active alarm		
Mode	Regeneration		
Minimum	0	Maximum	12
Default		Units	
Type	8 Bit Volatile	Update Rate	Background write
Display Format	Standard	Decimal Places	0
Coding	RO, TE, ND, NC, PT, BU		

Value	Text
0	None
1	Brake Resistor
2	Motor Overload
3	Ind Overload
4	Drive Overload
5	Auto Tune
6	Limit Switch
7	Fire Mode
8	Low Load
9	Option Slot 1
10	Option Slot 2
11	Option Slot 3
12	Option Slot 4

If there is no alarm then *Active Alarm* (10.104) = 0. If one alarm is active then *Active Alarm* (10.104) shows the value of the alarm. If more than one alarm is active then *Active Alarm* (10.104) shows the active alarm with the lowest value. The strings from this parameter are also used by the basic keypad to provide the status display text except for option slot warnings where the option module may supply the string.

Parameter	10.106 Potential Drive Damage Conditions		
Short description	Indicates that the user has put the drive in a condition that could potentially damage the drive		
Mode	Regeneration		
Minimum	0 (Display: 0000)	Maximum	15 (Display: 1111)
Default	Units		
Type	8 Bit Power Down Save	Update Rate	Background write
Display Format	Binary	Decimal Places	0
Coding	RO, ND, NC, PT, BU		

The bits in **Potential Drive Damage Conditions (10.106)** are set under the conditions shown in the table below to indicate that the user has put the drive in a condition that could potentially damage the drive. The bits in this parameter cannot be cleared by users.

Potential Drive Damage Conditions (10.106) bit	Condition
0	Fire mode has been active. See <i>Fire Mode Reference</i> (01.053).
1	<i>Low Under Voltage Threshold</i> (06.066) has been reduced from its default value.
2	High speed RFC-S mode has been used. See <i>Enable High Speed Mode</i> (05.022).
3	Not used.

Parameter	10.107 Auto-tune State		
Short description	Shows progress through auto-tuning		
Mode	Regeneration		
Minimum	0	Maximum	9
Default	Units		
Type	8 Bit Volatile	Update Rate	Background write
Display Format	Standard	Decimal Places	0
Coding	RO, TE, ND, NC, PT		

Value	Text
0	Not Active
1	Resistance
2	pLs
3	Ls
4	Flux
5	Flux Repeat
6	Ld Lq No-load
7	Lq
8	Ke
9	Inertia

No auto-tuning is provided at present in this mode, and so the parameter is always zero.

Menu 11 Single Line Descriptions – *Miscellaneous*

Mode: Regeneration

Parameter		Range	Default	Type						
11.001	Option Synchronisation Select	Not Active (0), Slot 1 (1), Slot 2 (2), Slot 3 (3), Automatic (5)	Slot 3 (3)	RW	Txt					US
11.002	Option synchronisation Active	Not Active (0), Slot 1 (1), Slot 2 (2), Slot 3 (3), Slot 4 (4)		RO	Txt	ND	NC	PT		
11.017	Keypad Defined Node Address	-2147483648 to 2147483647	0	RO	Num		NC	PT	PS	
11.018	Status Mode Parameter 1	0.000 to 59.999	0.000	RW	Num			PT	US	
11.019	Status Mode Parameter 2	0.000 to 59.999	0.000	RW	Num			PT	US	
11.021	Parameter 00.030 Scaling	0.000 to 10.000	1.000	RW	Num				US	
11.022	Parameter Displayed At Power-up	0.000 to 0.080	0.011	RW	Num			PT	US	
11.028	Drive Derivative	0 to 255		RO	Num	ND	NC	PT		
11.029	Software Version	0 to 999999999		RO	Num	ND	NC	PT		
11.030	User Security Code	0 to 2147483647		RW	Num	ND	NC	PT	US	
11.031	User Drive Mode	Open-loop (1), RFC-A (2), RFC-S (3), Regen (4)		RW	Txt	ND	NC	PT		
11.032	Maximum Heavy Duty Rating	0.000 to 99999.999 A		RO	Num	ND	NC	PT		
11.033	Drive Rated Voltage	200V (0), 400V (1), 575V (2), 690V (3)		RO	Txt	ND	NC	PT		
11.034	Software Sub-version	0 to 99		RO	Num	ND	NC	PT		
11.036	NV Media Card File Previously Loaded	0 to 999	0	RO	Num		NC	PT		
11.037	NV Media Card File Number	0 to 999	0	RW	Num					
11.038	NV Media Card File Type	None (0), Open-loop (1), RFC-A (2), RFC-S (3), Regen (4), User Prog (5)		RO	Txt	ND	NC	PT		
11.039	NV Media Card File Version	0 to 9999		RO	Num	ND	NC	PT		
11.040	NV Media Card File Checksum	-2147483648 to 2147483647		RO	Num	ND	NC	PT		
11.042	Parameter Cloning	None (0), Read (1), Program (2), Auto (3), Boot (4)	None (0)	RW	Txt		NC		US	
11.043	Load Defaults	None (0), Standard (1), US (2)	None (0)	RW	Txt		NC			
11.044	User Security Status	Menu 0 (0), All Menus (1), Read-only Menu 0 (2), Read-only (3), Status Only (4), No Access (5)		RW	Txt	ND		PT		
11.045	Select Motor 2 Parameters	Motor 1 (0), Motor 2 (1)	Motor 1 (0)	RW	Txt				US	
11.046	Defaults Previously Loaded	0 to 2000		RO	Num	ND	NC	PT	US	
11.047	Onboard User Program: Enable	Reset And Run (-1), Stop (0), Run (1)	Run (1)	RW	Txt				US	
11.048	Onboard User Program: Status	-2147483648 to 2147483647		RO	Num	ND	NC	PT		
11.049	Onboard User Program: Programming Events	0 to 65535		RO	Num	ND	NC	PT		
11.050	Onboard User Program: FreewheelingTasks Per Second	0 to 65535		RO	Num	ND	NC	PT		
11.051	Onboard User Program: Clock Task Time Used	0.0 to 100.0 %		RO	Num	ND	NC	PT		
11.052	Serial Number LS	000000000 to 999999999		RO	Num	ND	NC	PT		
11.053	Serial Number MS	0 to 999999999		RO	Num	ND	NC	PT		
11.054	Drive Date Code	0 to 65535		RO	Num	ND	NC	PT		
11.055	Onboard User Program: Clock Task Scheduled Interval	0 to 262140 ms		RO	Num	ND	NC	PT		
11.060	Maximum Rated Current	0.000 to 99999.999 A		RO	Num	ND	NC	PT		
11.061	Full Scale Current Kc	0.000 to 99999.999 A		RO	Num	ND	NC	PT		
11.062	Power Board Software Version Number	0.00 to 99.99		RO	Num	ND	NC	PT		
11.063	Product Type	0 to 255		RO	Num	ND	NC	PT		
11.064	Product Identifier Characters	1295463731 to 2147483647		RO	Num	ND	NC	PT		
11.065	Drive Rating And Configuration	00000000 to 99999999		RO	Num	ND	NC	PT		
11.066	Power Stage Identifier	0 to 255		RO	Num	ND	NC	PT		
11.067	Control Board Identifier	0.000 to 65.535		RO	Num	ND	NC	PT		
11.068	Internal I/O Identifier	0 to 255		RO	Num	ND	NC	PT		
11.069	Position Feedback Interface Identifier	0 to 255		RO	Num	ND	NC	PT		
11.070	Core Parameter Database Version	0.00 to 99.99		RO	Num	ND	NC	PT		
11.072	NV Media Card Create Special File	0 to 1	0	RW	Num		NC			
11.073	NV Media Card Type	None (0), SMART Card (1), SD Card (2)		RO	Txt	ND	NC	PT		
11.075	NV Media Card Read-only Flag	Off (0) or On (1)		RO	Bit	ND	NC	PT		
11.076	NV Media Card Warning Suppression Flag	Off (0) or On (1)		RO	Bit	ND	NC	PT		
11.077	NV Media Card File Required Version	0 to 9999		RW	Num	ND	NC	PT		
11.079	Drive Name Characters 1-4	-2147483648 to 2147483647	0	RW	Num			PT	US	
11.080	Drive Name Characters 5-8	-2147483648 to 2147483647	0	RW	Num			PT	US	
11.081	Drive Name Characters 9-12	-2147483648 to 2147483647	0	RW	Num			PT	US	
11.082	Drive Name Characters 13-16	-2147483648 to 2147483647	0	RW	Num			PT	US	

11.084	Drive Mode	Open-loop (1), RFC-A (2), RFC-S (3), Regen (4)		RO	Txt	ND	NC	PT	US
11.085	Security Status	None (0), Read-only (1), Status-only (2), No Access (3)		RO	Txt	ND	NC	PT	PS
11.086	Menu Access Status	Menu 0 (0), All Menus (1)		RO	Txt	ND	NC	PT	PS
11.090	Keypad Port Serial Address	1 to 16	1	RW	Num				US
11.091	Additional Identifier Characters 1	-2147483648 to 2147483647		RO	Num	ND	NC	PT	
11.092	Additional Identifier Characters 2	-2147483648 to 2147483647		RO	Num	ND	NC	PT	
11.093	Additional Identifier Characters 3	-2147483648 to 2147483647		RO	Num	ND	NC	PT	

RW	Read / Write	RO	Read-only	Bit	Bit parameter	Txt	Text string	Date	Date parameter	Time	Time parameter
Chr	Character parameter	Bin	Binary parameter	IP	IP address	Mac	MAC address	Ver	Version number	SMP	Slot, menu, parameter
Num	Number parameter	DE	Destination	ND	No default value	RA	Rating dependent	NC	Non-copyable	PT	Protected
Fl	Filtered	US	User save	PS	Power-down save						

Menu 11 – Miscellaneous

Mode: Regeneration

Menu 11 provides parameters for the following features:

1. General drive set-up and identification
2. Serial communications interface
3. Non-volatile media card access
4. Onboard user programming

Non-Volatile Media Card Support

The drive supports two types of non-volatile media cards; smart cards and FAT formatted SD cards.

The NV Media Card can be used for:

- Parameter copying between drives
- Saving drive parameter sets
- Saving an onboard user program
- Storing of onboard scope data (SD card only)

The NV Media Card can be used to store drive parameter sets and/or PLC programs set from the drive in data blocks 001 to 499 on the card.

The Unidrive M is compatible with a Unidrive SP smart card and is able to read and translate the Unidrive SP parameter set into a compatible parameter set for Unidrive M. This is only possible if the Unidrive SP parameter set was transferred to the smart card using the difference from defaults transfer method (i.e. 4yyy transfer). The Unidrive M is not able to read any other type of Unidrive SP data block on the card. Although it is possible to transfer difference from default data blocks from a Unidrive SP into the Unidrive M, the following should be noted:

1. If a parameter from the source drive does not exist in the target drive then no data is transferred for that parameter.
2. If the data for the parameter in the target drive is out of range then the data is limited to the range of the target parameter.
3. If the target drive has a different rating to the source drive then the normal rules for this type of transfer apply.

SD Card File system layout

The folder <MCDF/> ("Motor Control Data Files") must be present on a FAT-formatted SD card. Other folders can be added, but this folder and its contents must not be altered. This folder structure is created when a *Card Error* trip is reset. The drive will place files in a <MCDF/> folder in the card root. When individual items are saved by the drive (e.g. drive parameters or a user program), this will generate a numbered file in the root of this folder; the number is that specified in the triggering command, and this number must be specified in the command used to restore the item from the file. This is equivalent functionality to that provided on a smart card. When saving a parameter file, in addition to the drive parameters, the drive will also read the option parameters from each of the installed options, and include those that have changed in the parameter file.

Changing the drive mode

If the source drive mode is different from the target drive mode then the mode will be changed to the source drive mode before the parameters are transferred. If the required drive mode is outside the allowed range for the target then a *Card Drive Mode* trip is initiated and no data is transferred.

Different voltage ratings

If the voltage rating of the source and target drives is different then all parameters except those that are rating dependent are transferred to the target drive. The rating dependent parameters are left at their default values. After the parameters have been transferred and saved to non-volatile memory a *Card Rating* trip is given as a warning. The table below gives a list of the rating dependent parameters.

Parameters
Standard Ramp Voltage (02.008)
Voltage Set-point (03.005)
Reactive Power Input kVAR (03.020)
Regen Supply Loss a.c. Level (03.023)
Regen Minimum Voltage (03.026)
Regen Maximum Voltage (03.027)
Supply Voltage (03.028)
Motoring Current Limit / Power From Supply Current Limit (04.005)
M2 Motoring Current Limit / M2 Power From Supply Current Limit (21.027)
Regenerating Current Limit / Power To Supply Current Limit (04.006)
M2 Regenerating Current Limit / M2 Power To Supply Current Limit (21.028)
Symmetrical Current Limit (04.007)
M2 Symmetrical Current Limit (21.029)
User Current Maximum Scaling (04.024)
Rated Current (05.007)
M2 Rated Current (21.007)
Rated Voltage (05.009)
M2 Rated Voltage (21.009)
Rated Power Factor (05.010)
M2 Rated Power Factor (21.010)
Stator Resistance (05.017)
M2 Stator Resistance (21.012)
Maximum Switching Frequency (05.018)
Transient Inductance /Ld (05.024)
M2 Transient Inductance /Ld (21.014)
Stator Inductance (05.025)
M2 Stator Inductance (21.024)
No-load Lq (05.068)
M2 No-load Lq (21.041)
Rated Load Lq (05.069)
M2 Rated Load Lq (21.042)
No-load Phase Offset (05.070)
M2 No-load Phase Offset (21.043)
Rated Load Phase Offset (05.071)
M2 Rated Load Phase Offset (21.044)
Maximum Low Speed Sensorless Mode Current (05.072)
M2 Maximum Low Speed Sensorless Mode Current (05.045)
Injection Braking Level (06.006)
Supply Loss Detection Level (06.048)
Braking IGBT Lower Threshold (06.073)
Braking IGBT Upper Threshold (06.074)
Low Voltage Braking IGBT Threshold (06.075)

Different option modules fitted

If the *Option ID Code* (MM.001) is different for any option module fitted to the source drive compared to the destination drive then the parameters for the set-up and application menus for that option module are not transferred, but the parameters are set to their default values. After the parameters have been transferred and saved to non-volatile memory a {Card Option} trip is given as a warning

Different current ratings

If any of the current rating parameters (*Maximum Heavy Duty Rating* (11.032), *Maximum Rated Current* (11.060) or *Full Scale Current Kc* (11.061)) are different between the source and target then all parameters are still written to the target drive, but some may be limited by their allowed range. To give similar performance in the target compared to the source drive the speed and current controller gains are modified as shown below.

Gains	Multiplier
Speed Controller Proportional Gain Kp1 (03.010) Speed Controller Integral Gain Ki1 (03.011) Speed Controller Proportional Gain Kp2 (03.013) Speed Controller Integral Gain Ki2 (03.014)	[Source Full Scale Current Kc (11.061)] / [Target Full Scale Current Kc (11.061)]
M2 Speed Controller Proportional Gain Kp (21.017) M2 Speed Controller Integral Gain Ki (21.018)	
Current Controller Kp Gain (04.013) Current Controller Ki Gain (04.014)	[Target Full Scale Current Kc (11.061)] / [Source Full Scale Current Kc (11.061)]
M2 Current Controller Kp Gain (21.022) M2 Current Controller Ki Gain (21.023)	

Different variable maximums

It should be noted that if ratings of the source and target drives are different, or the option modules fitted to the source and target drives are different, it is possible that some parameters with variable maximums may be limited and not have the same values as in the source drive.

Macro files

Macro files are created in the same way as parameter files except that *NV Media Card Create Special File* (11.072) must be set to 1 before the file is created on the NV media card. *NV Media Card Create Special File* (11.072) is set to zero after the file has been created or the transfer fails. When a macro file is transferred to a drive the drive mode is not changed even if the actual mode is different to that in the file and defaults are not loaded before the parameters are copied from the file to the drive. The first three identification bytes at the start of a macro file are "MAC".

Onboard user program files

Onboard user program files are created with *Parameter mm.000* (mm.000) = 5xxx and the onboard user program image is transferred to the NV media card. The onboard user program image can be loaded from an onboard user program file with *Parameter mm.000* (mm.000) = 6xxx. If the drive does not have an onboard user program loaded when the onboard user program file is created then a file is created with an empty image. If this file is then transferred to a drive with an onboard user program loaded, the onboard user program will be erased.

Option module applications file

An option module applications file is intended to hold user program from an applications module. An option module applications file from the option module in slot 1 can be created with *Parameter mm.000* (mm.000) = 15xxx. An option module applications file can be transferred from an option module in slot 1 to an option module applications file with *Parameter mm.000* (mm.000) = 18xxx. If the transfer fails because the option module does not respond correctly a *Card Slot* trip is initiated where the sub-trip number is 1 (i.e. the option module slot number). Transfer to and from other option slots are initiated with other codes in *Parameter mm.000* (mm.000) as defined previously.

Parameter	11.001 Option Synchronisation Select		
Short description	Option Synchronisation Select		
Mode	Regeneration		
Minimum	0	Maximum	5
Default	3	Units	
Type	8 Bit User Save	Update Rate	Background Read
Display Format	Standard	Decimal Places	0
Coding	RW, TE		

Value	Text
0	Not Active
1	Slot 1
2	Slot 2
3	Slot 3
5	Automatic

Option Synchronisation Select (11.001) is used to select and enable timing synchronisation between the communications system associated with an option module fitted to the drive and the drive control system. If "Not Active" is selected then the drive control system operates using it's own processor crystal for control sample timing. If one of the option modules is selected and is making a request to provide synchronisation then the drive control sample timing will be synchronised to the communication system. *Option synchronisation Active* (11.002) shows the synchronisation source, where "Not Active" indicates that the drive is providing the timing for the control system. Any other value indicates if an option module is providing synchronisation. If required the synchronisation source can be selected automatically by setting *Option Synchronisation Select* (11.001) to "Automatic". In this case the option module in the lowest numbered slot that is making a request to provide synchronisation will be selected.

Parameter	11.002 Option synchronisation Active		
Short description	Option synchronisation Active		
Mode	Regeneration		
Minimum	0	Maximum	4
Default		Units	
Type	8 Bit Volatile	Update Rate	Background Write
Display Format	Standard	Decimal Places	0
Coding	RO, TE, ND, NC, PT		

Value	Text
0	Not Active
1	Slot 1
2	Slot 2
3	Slot 3
4	Slot 4

See *Option Synchronisation Select* (11.001).

Parameter	11.017 Keypad Defined Node Address		
Short description	Value that can be set up by some keypads to define the comms node address		
Mode	Regeneration		
Minimum	-2147483648	Maximum	2147483647
Default	0	Units	
Type	32 Bit Power Down Save	Update Rate	Background write
Display Format	Standard	Decimal Places	0
Coding	RO, NC, PT		

Keypad Defined Node Address (11.017) can be set up by some keypads and is intended to define a comms node address. As such it can be used to set the node address for the drive 485 serial comms. If the value of *Keypad Defined Node Address* (11.017) is between 1 and 247 and is different from *Serial Address* (11.023) then the value is copied to *Serial Address* (11.023) and *Reset Serial Communications* (11.020) is set to one. This has the effect of setting the 485 serial comms node address to the value defined by the keypad and re-initialising the comms system so that the new node address takes effect. As this is a power-down save parameter, once it is set to a value between 1 and 247 it will continue to over-ride the user serial port address unless it is changed again by a keypad.

Parameter	11.018 Status Mode Parameter 1		
Short description	Defines the parameter displayed on the upper row of the keypad when in status mode		
Mode	Regeneration		
Minimum	0.000	Maximum	59.999
Default	0.000	Units	
Type	16 Bit User Save	Update Rate	Background read
Display Format	Standard	Decimal Places	3
Coding	RW, PT, BU		

See *Parameter Displayed At Power-up* (11.022).

Parameter	11.019 Status Mode Parameter 2		
Short description	Defines the parameter displayed on the lower row of the keypad when in status mode		
Mode	Regeneration		
Minimum	0.000	Maximum	59.999
Default	0.000	Units	
Type	16 Bit User Save	Update Rate	Background read
Display Format	Standard	Decimal Places	3
Coding	RW, PT, BU		

See *Parameter Displayed At Power-up* (11.022).

Parameter	11.021 Parameter 00.030 Scaling		
Short description	Defines the scaling for Pr 00.030		
Mode	Regeneration		
Minimum	0.000	Maximum	10.000
Default	1.000	Units	
Type	16 Bit User Save	Update Rate	Background read
Display Format	Standard	Decimal Places	3
Coding	RW		

Parameter 00.030 Scaling (11.021) defines the scaling applied to parameter 00.030 when it is displayed on a basic keypad. The scaling is only applied in the status and view modes. If the parameter is edited via the keypad it reverts to its unscaled value during editing.

Parameter	11.022 Parameter Displayed At Power-up		
Short description	Defines which parameter is displayed at power-up		
Mode	Regeneration		
Minimum	0.000	Maximum	0.080
Default	0.011	Units	
Type	8 Bit User Save	Update Rate	Background read
Display Format	Standard	Decimal Places	3
Coding	RW, PT		

If *Status Mode Parameter 1* (11.018) and *Status Mode Parameter 2* (11.019) are set to zero, then *Parameter Displayed At Power-up* (11.022) defines which Menu 0 parameter is initially displayed at power-up. If *Status Mode Parameter 1* (11.018) or *Status Mode Parameter 2* (11.019) are set to valid parameter numbers, then *Parameter Displayed At Power-up* (11.022) defines the active parameter at power-up, i.e. the parameter first displayed when going in to parameter view mode on the keypad. *Status Mode Parameter 1* (11.018) and *Status Mode Parameter 2* (11.019) define the parameter values to be displayed on the upper and lower rows of the keypad respectively, when in status mode. If only one of these parameters is set correctly the other row will display the value of the current active parameter. If both *Status Mode Parameter 1* (11.018) and *Status Mode Parameter 2* (11.019) are set to the same parameter number then the parameter value is displayed as double height characters.

Parameter	11.028 Drive Derivative		
Short description	Displays the drive derivative identifier		
Mode	Regeneration		
Minimum	0	Maximum	255
Default		Units	
Type	8 Bit Volatile	Update Rate	Power-up write
Display Format	Standard	Decimal Places	0
Coding	RO, ND, NC, PT, BU		

Drive Derivative (11.028) shows the derivative identifier.

Parameter	11.029 Software Version		
Short description	Displays the software version in the drive		
Mode	Regeneration		
Minimum	0	Maximum	99999999
Default		Units	
Type	32 Bit Volatile	Update Rate	Power-up write
Display Format	Version	Decimal Places	0
Coding	RO, ND, NC, PT		

Software Version (11.029) displays the drive software version number as a decimal number wwxxyyzz. A keypad will display the value in this parameter as ww.xx.yy.zz.

Parameter	11.030 User Security Code		
Short description	Defines the user security code of the drive		
Mode	Regeneration		
Minimum	0	Maximum	2147483647
Default		Units	
Type	32 Bit User Save	Update Rate	Background read
Display Format	Standard	Decimal Places	0
Coding	RW, ND, NC, PT		

See *User Security Status* (11.044).

Parameter	11.031 User Drive Mode		
Short description	Defines the mode of the drive		
Mode	Regeneration		
Minimum	1	Maximum	4
Default		Units	
Type	8 Bit Volatile	Update Rate	Background read
Display Format	Standard	Decimal Places	0
Coding	RW, TE, ND, NC, PT		

Value	Text
1	Open-loop
2	RFC-A
3	RFC-S
4	Regen

User Drive Mode (11.031) is set to the current drive mode at power-up. The user can change the drive mode as follows:

1. Set *Parameter mm.000* (mm.000) to 1253, 1254, 1255 or 1256
2. Change *User Drive Mode* (11.031) to the required mode
3. Initiate a drive reset

Provided *Drive Active* (10.002) = 0 the drive will change to the new drive mode, and then load and save parameters to non-volatile memory. If *Parameter mm.000* (mm.000) is not set to one of the specified values then the drive mode does not change on drive reset. The value in *Parameter mm.000* (mm.000) determines which defaults are loaded as follows.

Parameter mm.000 (mm.000)	Defaults loaded
1253	50Hz defaults to all menus
1254	60Hz defaults to all menus
1255	50Hz defaults to all menus except 15 to 20 and 24 to 28
1256	60Hz defaults to all menus except 15 to 20 and 24 to 28

Parameter	11.032 Maximum Heavy Duty Rating		
Short description	Displays the maximum heavy duty current rating of the drive		
Mode	Regeneration		
Minimum	0.000	Maximum	99999.999
Default		Units	A
Type	32 Bit Volatile	Update Rate	Power-up write
Display Format	Standard	Decimal Places	3
Coding	RO, ND, NC, PT		

Maximum Heavy Duty Rating (11.032) defines the maximum setting for *Rated Current* (05.007) that gives heavy duty operation. If *Maximum Heavy Duty Rating* (11.032) = 0.000 then heavy duty operation is not possible. If *Maximum Heavy Duty Rating* (11.032) = VM_RATED_CURRENT[MAX] then normal duty operation is not possible.

Parameter	11.033 Drive Rated Voltage		
Short description	Displays the voltage rating of the drive		
Mode	Regeneration		
Minimum	0	Maximum	3
Default		Units	
Type	8 Bit Volatile	Update Rate	Power-up write
Display Format	Standard	Decimal Places	0
Coding	RO, TE, ND, NC, PT		

Value	Text
0	200V
1	400V
2	575V
3	690V

Drive Rated Voltage (11.033) shows the voltage rating of the drive.

Parameter	11.034 Software Sub-version		
Short description	Software Sub-version		
Mode	Regeneration		
Minimum	0	Maximum	99
Default		Units	
Type	8 Bit Volatile	Update Rate	Power-up Write
Display Format	Standard	Decimal Places	0
Coding	RO, ND, NC, PT		

For legacy applications *Software Sub-version* (11.034) shows the yy part of *Software Version* (11.029).

Parameter	11.036 NV Media Card File Previously Loaded		
Short description	Displays the number of the last parameter file transferred from an NV Media Card to the drive		
Mode	Regeneration		
Minimum	0	Maximum	999
Default	0	Units	
Type	16 Bit Volatile	Update Rate	Background write
Display Format	Standard	Decimal Places	0
Coding	RO, NC, PT		

NV Media Card File Previously Loaded (11.036) shows the number of the last parameter file transferred from an NV Media Card to the drive. If defaults are subsequently reloaded *NV Media Card File Previously Loaded* (11.036) is set to 0.

Parameter	11.037 NV Media Card File Number		
Short description	Selects a file by its file identification number		
Mode	Regeneration		
Minimum	0	Maximum	999
Default	0	Units	
Type	16 Bit Volatile	Update Rate	Background read
Display Format	Standard	Decimal Places	0
Coding	RW		

NV Media Card File Number (11.037) is used to select a file by its file identification number. When *NV Media Card File Number* (11.037) corresponds to the number of a file the following data about the file is shown.

Parameter
<i>NV Media Card File Type</i> (11.038)
<i>NV Media Card File Version</i> (11.039)
<i>NV Media Card File Checksum</i> (11.040)

The actions of erasing a card, erasing a file, creating a new file, changing a Menu 0 parameter or removing a card resets *NV Media Card File Number* (11.037) to 0.

Parameter	11.038 NV Media Card File Type		
Short description	Displays the file type of the file selected		
Mode	Regeneration		
Minimum	0	Maximum	5
Default		Units	
Type	8 Bit Volatile	Update Rate	Background write
Display Format	Standard	Decimal Places	0
Coding	RO, TE, ND, NC, PT		

Value	Text
0	None
1	Open-loop
2	RFC-A
3	RFC-S
4	Regen
5	User Prog

NV Media Card File Type (11.038) shows the file type of the file selected with *NV Media Card File Number* (11.037) as shown in the table below.

NV Media Card File Type (11.038)	File
0	No file selected
1	Open-loop mode parameter file
2	RFC-A mode parameter file
3	RFC-S mode parameter file
4	Regen mode parameter file
5	Onboard user program file

Parameter	11.039 NV Media Card File Version		
Short description	Displays the version number stored with the file selected		
Mode	Regeneration		
Minimum	0	Maximum	9999
Default		Units	
Type	16 Bit Volatile	Update Rate	Background write
Display Format	Standard	Decimal Places	0
Coding	RO, ND, NC, PT		

NV Media Card File Version (11.039) shows the version number stored with the file selected with *NV Media Card File Number* (11.037).

To set a file version number on a NV media card, the number required must be set in *NV Media Card File Required Version* (11.077) and then the data must be written to the NV media card. Failure to do this will result in no version number being displayed when selecting the NV media card file number in *NV Media Card File Number* (11.037).

Parameter	11.040 NV Media Card File Checksum		
Short description	Displays the checksum from the file selected		
Mode	Regeneration		
Minimum	-2147483648	Maximum	2147483647
Default		Units	
Type	32 Bit Volatile	Update Rate	Background write
Display Format	Standard	Decimal Places	0
Coding	RO, ND, NC, PT		

NV Media Card File Checksum (11.040) shows the checksum from the file selected with *NV Media Card File Number* (11.037). If the media file is a Unidrive SP SMARTCARD file, the checksum is the sum of all bytes except the checksum modulo 65536. If the file was generated by a Unidrive M, a value of zero will be displayed.

Parameter	11.042 Parameter Cloning		
Short description	Can be used to initiate a data transfer to or from an NV media card		
Mode	Regeneration		
Minimum	0	Maximum	4
Default	0	Units	
Type	8 Bit User Save	Update Rate	Background write
Display Format	Standard	Decimal Places	0
Coding	RW, TE, NC		

Value	Text
0	None
1	Read
2	Program
3	Auto
4	Boot

* Only a value of 3 or 4 in this parameter is saved.

Parameter Cloning (11.042) can also be used to initiate data transfer to or from an NV media card as described below for each possible value of this parameter.

1: Read

Provided a parameter file with file identification number 1 exists on the NV media card then setting *Parameter Cloning* (11.042) = 1 and initiating a drive reset will transfer the parameter data to the drive (i.e. the same action as writing 6001 to *Parameter mm.000* (mm.000)). When the action is complete *Parameter Cloning* (11.042) is automatically reset to zero.

2: Program

Setting *Parameter Cloning* (11.042) = 2 and initiating a drive reset will transfer the parameter data from the drive to a parameter file with file identification number 1. This is the same action as writing 4001 to *Parameter mm.000* (mm.000) except that the file will be overwritten if it already exists. When the action is complete *Parameter Cloning* (11.042) is automatically reset to zero.

3: Auto

Setting *Parameter Cloning* (11.042) = 3 and initiating a drive reset will transfer the parameter data from the drive to a parameter file with file identification number 1. This is the same action as writing 4001 to *Parameter mm.000* (mm.000) except that the file will be overwritten if it already exists. When the action is complete *Parameter Cloning* (11.042) remains at 3. It should be noted that if the drive is to remain in Auto mode after power-down and subsequent power-up a parameter save is required, unless *Parameter Cloning* (11.042) is being accessed from Menu 0, in which case it will be saved automatically.

If the card is removed when *Parameter Cloning* (11.042) = 3, then *Parameter Cloning* (11.042) is set to 0, which forces the user to change *Parameter Cloning* (11.042) back to 3 if auto mode is still required. The user will need to set *Parameter Cloning* (11.042) = 3 and initiate a drive reset to write the complete parameter set to the new card.

When a parameter in Menu zero is changed via the keypad and *Parameter Cloning* (11.042) = 3 the parameter is saved both to the drive non-volatile memory and to the parameter file with identification number 1 on the card. Only the new value of the modified parameter, and not the value of all the other drive parameters, is stored each time. If the drive did not automatically clear *Parameter Cloning* (11.042) when a card is removed, then when a new card is inserted that contains a parameter file with identification number 1 the modified parameter would be written to the existing file on the new card and the rest of the parameters in this file may not be the same as those in the drive.

When *Parameter Cloning* (11.042) = 3 and the drive parameters are saved to non-volatile memory, the file on the card is also updated, therefore this file becomes a copy of the drive parameters. At power up, if *Parameter Cloning* (11.042) = 3, the drive will save its complete parameter set to the card. This is done to ensure that if a card is inserted whilst the drive is powered down the new card will have the correct data after the drive is powered up again.

4: Boot

When *Parameter Cloning* (11.042) = 4 the drive operates in a similar way to *Parameter Cloning* (11.042) = 3 and automatically creates a copy of its parameters on the NV Media card. The NC (not clonable) attribute for *Parameter Cloning* (11.042) is 1, and so it does not have a value stored in the parameter file on the card in the normal way. However, the value of *Parameter Cloning* (11.042) is held in the parameter file header. If *Parameter Cloning* (11.042) = 4 in the parameter file with a file identification value of 1 on an NV media card fitted to a drive at power-up then the parameters from the parameter file with file identification number 1 are transferred to the drive and then saved in non-volatile memory. *Parameter Cloning* (11.042) is then set to 0 after the data transfer is complete.

It is possible to create a bootable parameter file by setting *Parameter mm.000* (mm.000) = 2001 and initiating a drive reset. This file is created in one operation and is not updated when further parameter changes are made.

When the drive is powered up it detects which option modules are fitted before loading parameters from an NV media card which has been set up for boot mode. If a new option module has been fitted since the last time the drive was powered up, a *Slot1 Different* trip is initiated and then the parameters are transferred from the card. If the parameter file includes the parameters for the newly fitted option module then these are also transferred to the drive and the *Slot1 Different* trip is reset. If the parameter file does not include the parameters for the newly fitted option module then the drive does not reset the *Slot1 Different* trip. Once the transfer is complete the drive parameters are saved to non-volatile memory. The trip can be reset either by initiating a drive reset or by powering down and then powering up again.

Parameter	11.043 Load Defaults		
Short description	Defines which defaults are to be loaded into the drive		
Mode	Regeneration		
Minimum	0	Maximum	2
Default	0	Units	
Type	8 Bit Volatile	Update Rate	Background read
Display Format	Standard	Decimal Places	0
Coding	RW, TE, NC		

Value	Text
0	None
1	Standard
2	US

If *Load Defaults* (11.043) is non-zero and a drive reset is initiated then the drive will load and save default parameters. If *Load Defaults* (11.043) = 1 then 50Hz defaults are loaded and if *Load Defaults* (11.043) = 2 then 60Hz defaults are loaded. This parameter has priority over actions defined by *Parameter mm.000* (mm.000) and *Parameter Cloning* (11.042). If *Load Defaults* (11.043) is used to initiate loading defaults then it is cleared along with *Parameter mm.000* (mm.000) and *Parameter Cloning* (11.042) when the action is completed.

Parameter	11.044 <i>User Security Status</i>		
Short description	defines the security level within the drive		
Mode	Regeneration		
Minimum	0	Maximum	5
Default		Units	
Type	8 Bit Volatile	Update Rate	Background read
Display Format	Standard	Decimal Places	0
Coding	RW, TE, ND, PT		

Value	Text
0	Menu 0
1	All Menus
2	Read-only Menu 0
3	Read-only
4	Status Only
5	No Access

Security

The drive provides a number of different levels of security that can be set by the user via *User Security Status* (11.044); these are shown in the table below.

Security Level	Description	<i>User Security Status</i> (11.044)
Menu 0	All writable parameters are available to be edited but only parameters in Menu 0 are visible.	0
All menus	All writable parameters are visible and available to be edited.	1
Read-only Menu 0	All parameters are read-only. Access is limited to Menu 0 parameters only.	2
Read-only	All parameters are read-only however all menus and parameters are visible.	3
Status only	The keypad remains in status mode and no parameters can be viewed or edited	4
No access	The keypad remains in status mode and no parameters can be viewed or edited. Drive parameters cannot be accessed via a comms/fieldbus interface in the drive or any option module.	5

When security has been set up the drive can either be in the locked or unlocked state. In the locked state the security level that has been set up applies. In the unlocked state the security is not active, but when the drive is powered down and powered up again the drive will be in the locked state. The drive may be relocked without powering down by selecting the required security level with the *User Security Status* (11.044) and initiating a drive reset.

Security can be set up as follows:

1. The *User Security Code* (11.030) should be set to the desired security unlock code (not zero). For security to remain set after power down then a parameter save should be performed to retain the set value.
2. If no further action is taken when the drive is powered down and then powered up read-only security will be set up and locked.
3. If at any time the *User Security Status* (11.044) is set to a value corresponding the one of the security levels shown in the table above and a drive reset is performed the security level is changed to that level. The desired security level is automatically saved and retained after power down, the keypad state changes to status mode and security is locked. (The security level that is active, provided *User Security Code* (11.030) has been saved as a non-zero value, if shown in *Security Status* (11.085).)

When security is set up and locked:

1. Parameter access is restricted as shown in the table above.
2. *User Security Code* (11.030) reads as zero except in parameter edit mode. Therefore it is not possible to read the value of the security code when any level of security is active and locked.

Security can be unlocked as follows:

1. If read-only security is set and locked then any attempt to edit any read/write parameter causes "Security code" to be displayed on the first row of the display. When the Up or Down keys are pressed the second row shows the code being adjusted. On setting the code the user presses the Enter key. If the correct code has been entered then the drive switches to Parameter edit mode on the parameter the user selected to edit, but if the correct code has not been entered the notification "Incorrect security code" is displayed for 2s and the drive returns to Parameter view mode.
2. If Status only or No access security is set and locked then any attempt to leave status mode causes the security code to be requested as per the process described above. If the security code entered must be correct for the keypad state machine to switch to the Parameter view mode. It is then possible to access all parameters normally.

Security can be cleared as follows:

1. Security must be unlocked.
2. The *User Security Code* (11.030) should be set to zero. For security to remain cleared after power down then a parameter save should be performed.

At any time *Security Status* (11.085) can be changed between 0 and 1 to restrict access to Menu 0 alone or to all menus. If the change is made by a keypad the new value becomes active on leaving parameter edit mode.

It should be that *Security Status* (11.085) is a volatile parameter and that the actual state of the security system is stored in *Security Status* (11.085) and *Menu Access Status* (11.086), which are both power-down save parameters. Therefore the security status will be stored when the drive goes into the under-voltage state. If the drive is already in the under-voltage state the security state should be saved by writing 1001 to *Parameter mm.000* (mm.000)

and initiating a reset.

Parameter	11.045 Select Motor 2 Parameters		
Short description	Set to 1 to select motor 2 parameters		
Mode	Regeneration		
Minimum	0	Maximum	1
Default	0	Units	
Type	8 Bit User Save	Update Rate	Background read
Display Format	Standard	Decimal Places	0
Coding	RW, TE		

Value	Text
0	Motor 1
1	Motor 2

Select Motor 2 Parameters (11.045) is used to select the motor map 2 parameters from Menu 21 to be substituted for the standard motor parameters. If *Select Motor 2 Parameters* (11.045) is modified when *Drive Active* (10.002) = 1 the change only becomes effective when *Drive Active* (10.002) = 0. When *Select Motor 2 Parameters* (11.045) = 1 the results from auto-tuning are written to the motor map 2 parameters in Menu 21 instead of to the standard parameters. Each time *Select Motor 2 Parameters* (11.045) is changed *Motor Protection Accumulator* (04.019) is reset to zero. *Select Motor 2 Parameters* (11.045) operates in the same way in Regen mode, but *Inductor Protection Accumulator* (04.019) is reset to zero each time the value is changed. *Motor 2 Active* (21.015) shows the motor map that is active.

Parameter	11.046 Defaults Previously Loaded		
Short description	Displays the defaults previously loaded in the drive		
Mode	Regeneration		
Minimum	0	Maximum	2000
Default		Units	
Type	16 Bit User Save	Update Rate	Background write
Display Format	Standard	Decimal Places	0
Coding	RO, ND, NC, PT		

Defaults Previously Loaded (11.046) shows the value used to load the previously loaded defaults (i.e. 1233 for 50Hz defaults, or 1244 for 60Hz defaults).

Parameter	11.047 Onboard User Program: Enable		
Short description	Enables the onboard user program		
Mode	Regeneration		
Minimum	-1	Maximum	1
Default	1	Units	
Type	8 Bit User Save	Update Rate	Background read
Display Format	Standard	Decimal Places	0
Coding	RW, TE		

Value	Text
-1	Reset And Run
0	Stop
1	Run

Onboard user programming provided a background task that loops continuously and a timed task that is executed each time at a defined rate. *Onboard User Program: Enable* (11.047) allows the onboard user program to be controlled as follows:

-1: Reset And Run

The onboard user program will run. If *Onboard User Program: Enable* (11.047) is changed from 0 (Stop) to -1 (Reset And Run) all variables will be reset to their initial values and the user program will run from the start.

0: Stop

The onboard user program is stopped.

1: Run

The onboard user program will run. If *Onboard User Program: Enable* (11.047) is changed from 0 (Stop) to 1 (Run) all variables will be unchanged and the user program will run from the start.

The effect of the above is as follows:

- If the drive powers up with *Onboard User Program: Enable* (11.047) set to either 1 or -1 then all variables will be reset to their initial values before the user program starts.
- If the drive powers up with *Onboard User Program: Enable* (11.047) set to 0, and then *Onboard User Program: Enable* (11.047) is changed to either 1 or -1 then all variables will be reset to their initial values before the user program starts.
- If *Onboard User Program: Enable* (11.047) is set to 0 and then to -1 then all variables will be reset to their initial values before the user program starts.
- If *Onboard User Program: Enable* (11.047) is set to 0 and then to 1 then all variables will be left at their previous values before the user program starts.

Parameter	11.048 Onboard User Program: Status		
Short description	Displays the status of the onboard user program		
Mode	Regeneration		
Minimum	-2147483648	Maximum	2147483647
Default		Units	
Type	32 Bit Volatile	Update Rate	Background write
Display Format	Standard	Decimal Places	0
Coding	RO, ND, NC, PT		

Onboard User Program: Status (11.048) shows the status of the onboard user program.

Value	Description
0	A user program is present but is stopped
1	The user program is running
2	The user program has an exception
3	No user program is present

Parameter	11.049 Onboard User Program: Programming Events		
Short description	Displays the number of programming events of the onboard user program		
Mode	Regeneration		
Minimum	0	Maximum	65535
Default		Units	
Type	16 Bit Volatile	Update Rate	Background write
Display Format	Standard	Decimal Places	0
Coding	RO, ND, NC, PT, BU		

Onboard User Program: Programming Events (11.049) = 0 when the drive is manufactured and is incremented each time an onboard user program image is written to the drive. If an onboard user program image is written more than 65535 times *Onboard User Program: Programming Events* (11.049) = 65535. *Onboard User Program: Programming Events* (11.049) shows how many times the flash memory within the drive has been reprogrammed.

Parameter	11.050 Onboard User Program: FreewheelingTasks Per Second		
Short description	Displays the rate of freewheeling tasks of the onboard user program		
Mode	Regeneration		
Minimum	0	Maximum	65535
Default		Units	
Type	16 Bit Volatile	Update Rate	One Second Background Write
Display Format	Standard	Decimal Places	0
Coding	RO, ND, NC, PT, BU		

During each scan in a freewheeling task it is possible to give an indication to the drive that the scan loop is starting. If this indication is given then *Onboard User Program: FreewheelingTasks Per Second* (11.050) will give the number of times this indication is given per second. It should be noted that this parameter is updated once per second. Because the background time slot for the user program background task occurs every 64ms (15.625 times per second) either 15 or 16 time slots could have been allocated over the monitoring period. Therefore the value given by this parameter can step between two values, one corresponding to the number of updates for 15 slots, and the one corresponding to the number of updates for to 16 slots.

Parameter	11.051 Onboard User Program: Clock Task Time Used		
Short description	Displays the percentage of the available time used by the onboard user program clock task		
Mode	Regeneration		
Minimum	0.0	Maximum	100.0
Default		Units	%
Type	16 Bit Volatile	Update Rate	Background write
Display Format	Standard	Decimal Places	1
Coding	RO, ND, NC, PT		

Onboard User Program: Clock Task Time Used (11.051) shows the percentage of the available time used by the onboard user program clock task.

Parameter	11.052 Serial Number LS		
Short description	Shows the least significant 9 decimal digits of the drive serial number		
Mode	Regeneration		
Minimum	0 (Display: 000000000)	Maximum	999999999 (Display: 999999999)
Default		Units	
Type	32 Bit Volatile	Update Rate	Power-up write
Display Format	Lead Zero Pad	Decimal Places	0
Coding	RO, ND, NC, PT		

The drive serial number is available as a pair of 32 bit values where *Serial Number LS* (11.052) provides the least significant 9 decimal digits and *Serial Number MS* (11.053) provides the most significant 9 decimal digits. The reconstructed serial number is ((11.053 * 100000000) + 11.052).

Example 1
Serial number "1234567898765" would be stored as 11.053 = 1234, 11.052 = 567898765.

Example 2

Serial number "1234000056789" would be stored as 11.053 = 1234, 11.052 = 56789. *Serial Number LS* (11.052) will be shown on the keypad as 000056789 (i.e. including the leading zeros).

Parameter	11.053 <i>Serial Number MS</i>		
Short description	Shows the most significant 9 decimal digits of the drive serial number		
Mode	Regeneration		
Minimum	0	Maximum	999999999
Default		Units	
Type	32 Bit Volatile	Update Rate	Power-up write
Display Format	Standard	Decimal Places	0
Coding	RO, ND, NC, PT		

See *Serial Number LS* (11.052).

Parameter	11.054 <i>Drive Date Code</i>		
Short description	Shows the drive date code		
Mode	Regeneration		
Minimum	0	Maximum	65535
Default		Units	
Type	16 Bit Volatile	Update Rate	Background write
Display Format	Standard	Decimal Places	0
Coding	RO, ND, NC, PT, BU		

Drive Date Code (11.054) is a four-digit number in the form yyww where yy is the year and ww the week number.

Parameter	11.055 <i>Onboard User Program: Clock Task Scheduled Interval</i>		
Short description	Displays the interval at which the clock task is scheduled in ms		
Mode	Regeneration		
Minimum	0	Maximum	262140
Default		Units	ms
Type	32 Bit Volatile	Update Rate	Background write
Display Format	Standard	Decimal Places	0
Coding	RO, ND, NC, PT		

Onboard User Program: Clock Task Scheduled Interval (11.055) shows the interval at which the clock task is scheduled to run at in ms.

Parameter	11.060 <i>Maximum Rated Current</i>		
Short description	Displays the maximum rated current or normal duty rating of the drive		
Mode	Regeneration		
Minimum	0.000	Maximum	99999.999
Default		Units	A
Type	32 Bit Volatile	Update Rate	Power-up write
Display Format	Standard	Decimal Places	3
Coding	RO, ND, NC, PT		

Maximum Rated Current (11.060) defines the variable maximum VM_RATED_CURRENT[MAX] which defines the maximum *Rated Current* (05.007). Therefore *Maximum Rated Current* (11.060) is the maximum rated current for normal duty operation (if normal duty operation is allowed).

Parameter	11.061 <i>Full Scale Current Kc</i>		
Short description	Displays the full scale current Kc		
Mode	Regeneration		
Minimum	0.000	Maximum	99999.999
Default		Units	A
Type	32 Bit Volatile	Update Rate	Power-up write
Display Format	Standard	Decimal Places	3
Coding	RO, ND, NC, PT		

Full Scale Current Kc (11.061) shows the full scale current in r.m.s. Amps. If the drive current exceeds this level it will cause an over current trip.

Parameter	11.062 <i>Power Board Software Version Number</i>		
Short description	Power Board Software Version Number		
Mode	Regeneration		
Minimum	0.00	Maximum	99.99
Default		Units	
Type	16 Bit Volatile	Update Rate	Background Write
Display Format	Standard	Decimal Places	2
Coding	RO, ND, NC, PT		

Power Board Software Version Number (11.062) gives the version for the power board connected to the control board or the power board in node 1 of a

multi-power module drive.

Parameter	11.063 Product Type		
Short description	Displays the core product type		
Mode	Regeneration		
Minimum	0	Maximum	255
Default	Units		
Type	8 Bit Volatile	Update Rate	Power-up write
Display Format	Standard	Decimal Places	0
Coding	RO, ND, NC, PT, BU		

Product Type (11.063) shows the core product type as given in the table below. The drive could be the basic product or a derivative of the basic product as defined by *Drive Derivative* (11.028).

Product Type (11.063)	Core product range
0	Unidrive M

Parameter	11.064 Product Identifier Characters		
Short description	Displays the product identifier characters		
Mode	Regeneration		
Minimum	1295463731	Maximum	2147483647
Default	Units		
Type	32 Bit Volatile	Update Rate	Power-up write
Display Format	String	Decimal Places	0
Coding	RO, ND, NC, PT		

The drive model and rating can be identified as AAAA B nnnnnnnn CCCC DD EE FFF where each section of the model identifier is taken from a parameter. AAAA, B, CCCC, DDDD, EE and FFF are alpha-numeric characters. nnnnnnnn are decimal digits.

Section of Identifier	Parameter
AAAA	<i>Product Identifier Characters</i> (11.064)
nnnnnnnn	<i>Drive Rating And Configuration</i> (11.065)
CCCC	<i>Additional Identifier Characters 1</i> (11.091)
DDEE	<i>Additional Identifier Characters 2</i> (11.092)
FFFF	<i>Additional Identifier Characters 3</i> (11.093)

Drive Rating And Configuration (11.065) is split into a number of fields as defined in the table below.

Digits	Meaning
7 and 6	Frame size
5	Voltage code (2 = 200V, 4 = 400V, 5 = 575V, 6 = 690V)
4 and 0	Current rating multiplied by 10. If the drive has a heavy and normal duty rating (i.e. <i>Maximum Heavy Duty Rating</i> (11.032) > 0 and <i>Maximum Rated Current</i> (11.060) > <i>Maximum Heavy Duty Rating</i> (11.032)), or the drive only has a heavy duty rating (i.e. <i>Maximum Heavy Duty Rating</i> (11.032) = <i>Maximum Rated Current</i> (11.060)), then the current rating is derived from <i>Maximum Heavy Duty Rating</i> (11.032). Otherwise if the drive only has a normal duty rating (i.e. <i>Maximum Heavy Duty Rating</i> (11.032) = 0) then the current rating is derived from <i>Maximum Rated Current</i> (11.060).

Example

The model number M700-03400078 A001 00 AB100 would be displayed in parameters as follows

Parameter	Value
<i>Product Identifier Characters</i> (11.064)	M700
<i>Drive Rating And Configuration</i> (11.065)	03400078
<i>Additional Identifier Characters 1</i> (11.091)	A001
<i>Additional Identifier Characters 2</i> (11.092)	00AB
<i>Additional Identifier Characters 3</i> (11.093)	100-

Parameter	11.065 Drive Rating And Configuration		
Short description	Displays the drive rating and configuration		
Mode	Regeneration		
Minimum	0 (Display: 00000000)	Maximum	99999999 (Display: 99999999)
Default	Units		
Type	32 Bit Volatile	Update Rate	Power-up write
Display Format	Lead Zero Pad	Decimal Places	0
Coding	RO, ND, NC, PT		

See *Product Identifier Characters* (11.064).

Parameter	11.066 Power Stage Identifier		
Short description	Displays the power stage identifiers within the drive		
Mode	Regeneration		
Minimum	0	Maximum	255
Default		Units	
Type	8 Bit Volatile	Update Rate	Power-up write
Display Format	Standard	Decimal Places	0
Coding	RO, ND, NC, PT, BU		

Power Stage Identifier (11.066) is used to show power stages that require changes to the drive user parameters (i.e. visibility, range or defaults). It should be noted that this parameter does not identify the rating of the power stage.

Power Stage Identifier (11.066)	Power Stage
0	Standard Unidrive M
1	Unidrive M with no braking IGBT
2	Servo drive

Parameter	11.067 Control Board Identifier		
Short description	Displays the control board identifiers within the drive		
Mode	Regeneration		
Minimum	0.000	Maximum	65.535
Default		Units	
Type	16 Bit Volatile	Update Rate	Power-up write
Display Format	Standard	Decimal Places	3
Coding	RO, ND, NC, PT, BU		

Control Board Identifier (11.067) identifies the control board hardware in the form A.BBB. BBB is the hardware identifier from the control board and A indicates whether this is a standard or high speed product as given in the table below.

A	BBB	Control Board
0	002 or 003	Unidrive M - Standard
1	002 or 003	Unidrive M - High Speed
0	004	Servo

Parameter	11.068 Internal I/O Identifier		
Short description	Displays the internal I/O identifiers within the drive		
Mode	Regeneration		
Minimum	0	Maximum	255
Default		Units	
Type	8 Bit Volatile	Update Rate	Power-up write
Display Format	Standard	Decimal Places	0
Coding	RO, ND, NC, PT, BU		

Internal I/O Identifier (11.068) identifies the internally fitted I/O option as given in the table below.

Internal I/O Identifier (11.068)	Internal I/O
0	Analog and digital I/O
1	Digital only I/O
2	Analogue and digital I/O with additional relay
3	Servo drive I/O

The tables below show which I/O functions are available for each of the internally fitted I/O options.

AI/O	0	1	2	3
Analogue Input 1	All except Disable		All except Disable	Voltage
Analogue Input 2	All except Disable		All except Disable	
Analogue Input 3	Voltage, Thermistor	Thermistor, Disable	Voltage	
Analogue Output 1	Voltage		All	
Analogue Output 2	Voltage		All	

DI/O	Function	0	1	2	3
1	Input/Output	Input/Output	Output	Input/Output	Output
2	Input/Output	Input/Output	Output	Input/Output	Output
3	Input/Output	Input/Output		Input/Output	
4	Input	Input	Input	Input	Input
5	Input	Input	Input	Input	Input
6	Input	Input		Input	
7	Relay Output	Output	Output	Output	
8	24V Supply Output	Output	Output	Output	Output
9	Safe Torque Off 1	Input	Input	Input	Input
10	Safe Torque Off 2	Input ¹	Input	Input ¹	Input
11	Keypad Run Button	Input	Input	Input	
12	Keypad Auxiliary Button	Input	Input	Input	
13	24V Supply Input	Input	Input	Input	
14	Keypad Stop Button	Input	Input	Input	
15	Relay 2 Output			Output	
16	Reset button				Input

1 Only one hardware input is provided which is shared by STO1 and STO2.

Parameter	11.069 Position Feedback Interface Identifier		
Short description	Displays the position feedback interface identifier within the drive		
Mode	Regeneration		
Minimum	0	Maximum	255
Default		Units	
Type	8 Bit Volatile	Update Rate	Power-up write
Display Format	Standard	Decimal Places	0
Coding	RO, ND, NC, PT, BU		

Position Feedback Interface Identifier (11.069) identifies the type of interface fitted in the position feedback interface option location as given in the table below.

Position Feedback Interface Identifier (11.069)	Position feedback interface
0	Standard Position Feedback
1	None
2	User Comms Module

Parameter	11.070 Core Parameter Database Version		
Short description	Displays the core parameter database version within the drive		
Mode	Regeneration		
Minimum	0.00	Maximum	99.99
Default		Units	
Type	16 Bit Volatile	Update Rate	Power-up write
Display Format	Standard	Decimal Places	2
Coding	RO, ND, NC, PT		

Core Parameter Database Version (11.070) gives the version number of the parameter database used to define the core parameter menus in the drive (Menu 1 to 14 and 21 to 23) in 2 digit BCD format. All other menus are customisable and if these menus are changed their default values are automatically loaded. However, if the drive software is changed it may be necessary to load defaults for all menus, although this will only be required rarely. Defaults for all menus are loaded when the most significant digit of Core Parameter Database Version (11.070) changes. Therefore if the drive firmware is modified and the most significant digit of the core database version has changed an EEPROM Fail.001 trip is initiated and default parameters are loaded.

Parameter	11.072 NV Media Card Create Special File		
Short description	Defines if a parameter file is created as a macro file during transfer		
Mode	Regeneration		
Minimum	0	Maximum	1
Default	0	Units	
Type	8 Bit Volatile	Update Rate	Background read
Display Format	Standard	Decimal Places	0
Coding	RW, NC		

If NV Media Card Create Special File (11.072) = 1 when a parameter file is transferred to an NV media card the file is created as a macro file. NV Media Card Create Special File (11.072) is reset to 0 after the file is created or the transfer fails.

Parameter	11.073 NV Media Card Type		
Short description	Displays the type of the currently fitted NV media card		
Mode	Regeneration		
Minimum	0	Maximum	2
Default		Units	
Type	8 Bit Volatile	Update Rate	Background write
Display Format	Standard	Decimal Places	0
Coding	RO, TE, ND, NC, PT		

Value	Text	Description
0	None	No media card has been inserted
1	SMART Card	A SMART Card has been inserted
2	SD Card	A FAT formatted SD card has been inserted

NV Media Card File Type (11.038) shows the type of non-volatile media card inserted in the drive.

Parameter	11.075 NV Media Card Read-only Flag		
Short description	Displays the state of the read-only flag for the currently fitted card		
Mode	Regeneration		
Minimum	0	Maximum	1
Default		Units	
Type	1 Bit Volatile	Update Rate	Background write
Display Format	Standard	Decimal Places	0
Coding	RO, ND, NC, PT		

NV Media Card Read-only Flag (11.075) shows the state of the read-only flag for the currently fitted card.

Parameter	11.076 NV Media Card Warning Suppression Flag		
Short description	Displays the state of the warning flag for the currently fitted card		
Mode	Regeneration		
Minimum	0	Maximum	1
Default		Units	
Type	1 Bit Volatile	Update Rate	Background write
Display Format	Standard	Decimal Places	0
Coding	RO, ND, NC, PT		

NV Media Card Warning Suppression Flag (11.076) shows the state of the warning flag for the currently fitted card.

Parameter	11.077 NV Media Card File Required Version		
Short description	Displays the version number for a file when it is created on an NV media card		
Mode	Regeneration		
Minimum	0	Maximum	9999
Default		Units	
Type	16 Bit Volatile	Update Rate	Background write
Display Format	Standard	Decimal Places	0
Coding	RW, ND, NC, PT		

The value of NV Media Card File Required Version (11.077) is used as the version number for a file when it is created on an NV media card. NV Media Card File Required Version (11.077) is reset to 0 when the file is created or the transfer fails.

Parameter	11.079 Drive Name Characters 1-4		
Short description	Defines characters 1-4 of a string which can be used to identify the drive		
Mode	Regeneration		
Minimum	-2147483648	Maximum	2147483647
Default	0	Units	
Type	32 Bit User Save	Update Rate	N/A
Display Format	String	Decimal Places	0
Coding	RW, PT		

Drive Name Characters 1-4 (11.079) to Drive Name Characters 13-16 (11.082) can be used to store a 16 character string which can be used to identify the drive. The string is arranged as shown below.

1	4	5	8	9	12	13	16
Pr 11.079		Pr 11.080		Pr 11.082		Pr 11.083	

This uses the standard ASCII character set.

Parameter	11.080 Drive Name Characters 5-8		
Short description	Defines characters 5-8 of a string which can be used to identify the drive		
Mode	Regeneration		
Minimum	-2147483648	Maximum	2147483647
Default	0	Units	
Type	32 Bit User Save	Update Rate	N/A
Display Format	String	Decimal Places	0
Coding	RW, PT		

See *Drive Name Characters 1-4* (11.079).

Parameter	11.081 Drive Name Characters 9-12		
Short description	Defines characters 9-12 of a string which can be used to identify the drive		
Mode	Regeneration		
Minimum	-2147483648	Maximum	2147483647
Default	0	Units	
Type	32 Bit User Save	Update Rate	N/A
Display Format	String	Decimal Places	0
Coding	RW, PT		

See *Drive Name Characters 1-4* (11.079).

Parameter	11.082 Drive Name Characters 13-16		
Short description	Defines characters 13-16 of a string which can be used to identify the drive		
Mode	Regeneration		
Minimum	-2147483648	Maximum	2147483647
Default	0	Units	
Type	32 Bit User Save	Update Rate	N/A
Display Format	String	Decimal Places	0
Coding	RW, PT		

See *Drive Name Characters 1-4* (11.079).

Parameter	11.084 Drive Mode		
Short description	Defines and displays the current drive mode		
Mode	Regeneration		
Minimum	1	Maximum	4
Default		Units	
Type	8 Bit User Save	Update Rate	Background read/write
Display Format	Standard	Decimal Places	0
Coding	RO, TE, ND, NC, PT		

Value	Text
1	Open-loop
2	RFC-A
3	RFC-S
4	Regen

Drive Mode (11.084) is used to hold the currently active drive mode.

Parameter	11.085 Security Status		
Short description	Displays the security status within the drive		
Mode	Regeneration		
Minimum	0	Maximum	3
Default		Units	
Type	8 Bit Power Down Save	Update Rate	Background write
Display Format	Standard	Decimal Places	0
Coding	RO, TE, ND, NC, PT		

Value	Text
0	None
1	Read-only
2	Status-only
3	No Access

Security Status (11.085) shows the security that will apply when security is enabled by setting a non-zero value for *User Security Code* (11.030).

Parameter	11.086 Menu Access Status		
Short description	Displays the amount of access of the menus within the drive		
Mode	Regeneration		
Minimum	0	Maximum	1
Default		Units	
Type	8 Bit Power Down Save	Update Rate	Background write
Display Format	Standard	Decimal Places	0
Coding	RO, TE, ND, NC, PT		

Value	Text
0	Menu 0
1	All Menus

If *Menu Access Status* (11.086) = 0 then only Menu 0 can be accessed with a keypad. If *Menu Access Status* (11.086) = 1 then all menus can be accessed with a keypad.

Parameter	11.090 Keypad Port Serial Address		
Short description	Defines the node address for the keypad port serial comms interface		
Mode	Regeneration		
Minimum	1	Maximum	16
Default	1	Units	
Type	8 Bit User Save	Update Rate	Background read
Display Format	Standard	Decimal Places	0
Coding	RW		

Keypad Port Serial Address (11.090) defines the node address for the keypad port serial comms interface. Normally the default value of 1 is used, but this can be changed if required. The keypad attached to the port will sense the address automatically.

Parameter	11.091 Additional Identifier Characters 1		
Short description	Displays the additional identifier characters		
Mode	Regeneration		
Minimum	-2147483648	Maximum	2147483647
Default		Units	
Type	32 Bit Volatile	Update Rate	Power-up write
Display Format	String	Decimal Places	0
Coding	RO, ND, NC, PT		

See *Product Identifier Characters* (11.064).

Parameter	11.092 Additional Identifier Characters 2		
Short description	Displays the additional identifier characters		
Mode	Regeneration		
Minimum	-2147483648	Maximum	2147483647
Default		Units	
Type	32 Bit Volatile	Update Rate	Power-up write
Display Format	String	Decimal Places	0
Coding	RO, ND, NC, PT		

See *Product Identifier Characters* (11.064).

Parameter	11.093 Additional Identifier Characters 3		
Short description	Displays the additional identifier characters		
Mode	Regeneration		
Minimum	-2147483648	Maximum	2147483647
Default		Units	
Type	32 Bit Volatile	Update Rate	Power-up write
Display Format	String	Decimal Places	0
Coding	RO, ND, NC, PT		

See *Product Identifier Characters* (11.064).

Menu 12 Single Line Descriptions – User Functions 2

Mode: Regeneration

Parameter		Range	Default	Type					
12.001	Threshold Detector 1 Output	Off (0) or On (1)		RO	Bit	ND	NC	PT	
12.002	Threshold Detector 2 Output	Off (0) or On (1)		RO	Bit	ND	NC	PT	
12.003	Threshold Detector 1 Source	0.000 to 59.999	0.000	RW	Num			PT	US
12.004	Threshold Detector 1 Level	0.00 to 100.00 %	0.00 %	RW	Num				US
12.005	Threshold Detector 1 Hysteresis	0.00 to 25.00 %	0.00 %	RW	Num				US
12.006	Threshold Detector 1 Output Invert	Off (0) or On (1)	Off (0)	RW	Bit				US
12.007	Threshold Detector 1 Destination	0.000 to 59.999	0.000	RW	Num	DE		PT	US
12.008	Variable Selector 1 Source 1	0.000 to 59.999	0.000	RW	Num			PT	US
12.009	Variable Selector 1 Source 2	0.000 to 59.999	0.000	RW	Num			PT	US
12.010	Variable Selector 1 Mode	Input 1 (0), Input 2 (1), Add (2), Subtract (3), Multiply (4), Divide (5), Time Const (6), Ramp (7), Modulus (8), Powers (9), Sectional (10)	Input 1 (0)	RW	Txt				US
12.011	Variable Selector 1 Destination	0.000 to 59.999	0.000	RW	Num	DE		PT	US
12.012	Variable Selector 1 Output	±100.00 %		RO	Num	ND	NC	PT	
12.013	Variable Selector 1 Source 1 Scaling	±4.000	1.000	RW	Num				US
12.014	Variable Selector 1 Source 2 Scaling	±4.000	1.000	RW	Num				US
12.015	Variable Selector 1 Control	0.00 to 100.00	0.00	RW	Num				US
12.016	Variable Selector 1 Enable	Off (0) or On (1)	On (1)	RW	Bit				US
12.023	Threshold Detector 2 Source	0.000 to 59.999	0.000	RW	Num			PT	US
12.024	Threshold Detector 2 Level	0.00 to 100.00	0.00	RW	Num				US
12.025	Threshold Detector 2 Hysteresis	0.00 to 25.00	0.00	RW	Num				US
12.026	Threshold Detector 2 Output Invert	Off (0) or On (1)	Off (0)	RW	Bit				US
12.027	Threshold Detector 2 Destination	0.000 to 59.999	0.000	RW	Num	DE		PT	US
12.028	Variable Selector 2 Source 1	0.000 to 59.999	0.000	RW	Num			PT	US
12.029	Variable Selector 2 Source 2	0.000 to 59.999	0.000	RW	Num			PT	US
12.030	Variable Selector 2 Mode	Input 1 (0), Input 2 (1), Add (2), Subtract (3), Multiply (4), Divide (5), Time Const (6), Ramp (7), Modulus (8), Powers (9), Sectional (10)	Input 1 (0)	RW	Txt				US
12.031	Variable Selector 2 Destination	0.000 to 59.999	0.000	RW	Num	DE		PT	US
12.032	Variable Selector 2 Output	±100.00 %		RO	Num	ND	NC	PT	
12.033	Variable Selector 2 Source 1 Scaling	±4.000	1.000	RW	Num				US
12.034	Variable Selector 2 Source 2 Scaling	±4.000	1.000	RW	Num				US
12.035	Variable Selector 2 Control	0.00 to 100.00	0.00	RW	Num				US
12.036	Variable Selector 2 Enable	Off (0) or On (1)	On (1)	RW	Bit				US

RW	Read / Write	RO	Read-only	Bit	Bit parameter	Txt	Text string	Date	Date parameter	Time	Time parameter
Chr	Character parameter	Bin	Binary parameter	IP	IP address	Mac	MAC address	Ver	Version number	SMP	Slot, menu, parameter
Num	Number parameter	DE	Destination	ND	No default value	RA	Rating dependent	NC	Non-copyable	PT	Protected
FI	Filtered	US	User save	PS	Power-down save						

Menu 12 – User Functions 2

Mode: Regeneration

Parameter	12.001 Threshold Detector 1 Output		
Short description	Displays the output of threshold detector 1		
Mode	Regeneration		
Minimum	0	Maximum	1
Default		Units	
Type	1 Bit Volatile	Update Rate	4ms write
Display Format	Standard	Decimal Places	0
Coding	RO, ND, NC, PT		

The threshold detector functions are always active even if the source and destination are not routed to valid parameters. If the source is not a valid parameter then the source value is taken as 0. The update rate for each of the threshold detector functions is always 4ms.

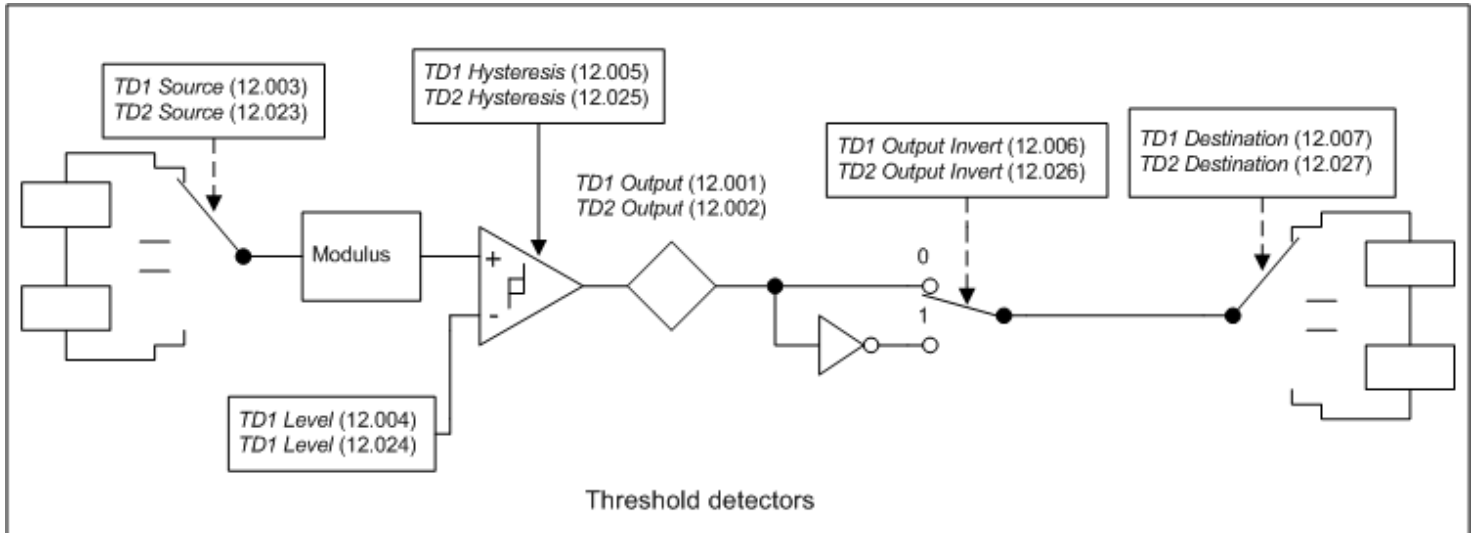

The following description is for threshold detector 1, but threshold detector 2 operates in the same way. The level of the parameter defined by *Threshold Detector 1 Source* (12.003) is converted to a percentage and compared to *Threshold Detector 1 Level* (12.004) with hysteresis to give *Threshold Detector 1 Output* (12.001) as follows:

Source	Threshold Detector 1 Output (12.001)
Source	0
Lower threshold \leq Source	No change of state
Source \geq Upper threshold	1

Lower threshold = *Threshold Detector 1 Level* (12.004) - *Threshold Detector 1 Hysteresis* (12.005)
 Upper threshold = *Threshold Detector 1 Level* (12.004) + *Threshold Detector 1 Hysteresis* (12.005)

The output value can then be inverted with *Threshold Detector 1 Output Invert* (12.006) before being routed to the destination defined by *Threshold Detector 1 Destination* (12.007).

Parameter	12.002 Threshold Detector 2 Output		
Short description	Displays the output of threshold detector 1		
Mode	Regeneration		
Minimum	0	Maximum	1
Default		Units	
Type	1 Bit Volatile	Update Rate	4ms write
Display Format	Standard	Decimal Places	0
Coding	RO, ND, NC, PT		

See *Threshold Detector 1 Output* (12.001).

Parameter	12.003 Threshold Detector 1 Source		
Short description	Defines the source parameter for threshold detector 1		
Mode	Regeneration		
Minimum	0.000	Maximum	59.999
Default	0.000	Units	
Type	16 Bit User Save	Update Rate	Drive reset read
Display Format	Standard	Decimal Places	3
Coding	RW, PT, BU		

See *Threshold Detector 1 Output* (12.001).

Parameter	12.004 Threshold Detector 1 Level		
Short description	Defines the reference level for threshold detector 1		
Mode	Regeneration		
Minimum	0.00	Maximum	100.00
Default	0.00	Units	%
Type	16 Bit User Save	Update Rate	4ms read
Display Format	Standard	Decimal Places	2
Coding	RW		

See *Threshold Detector 1 Output* (12.001).

Parameter	12.005 Threshold Detector 1 Hysteresis		
Short description	Defines the hysteresis for threshold detector 1		
Mode	Regeneration		
Minimum	0.00	Maximum	25.00
Default	0.00	Units	%
Type	16 Bit User Save	Update Rate	4ms read
Display Format	Standard	Decimal Places	2
Coding	RW		

See *Threshold Detector 1 Output* (12.001).

Parameter	12.006 Threshold Detector 1 Output Invert		
Short description	Set to 1 to invert the output of threshold detector 1		
Mode	Regeneration		
Minimum	0	Maximum	1
Default	0	Units	
Type	1 Bit User Save	Update Rate	4ms read
Display Format	Standard	Decimal Places	0
Coding	RW		

See *Threshold Detector 1 Output* (12.001).

Parameter	12.007 Threshold Detector 1 Destination		
Short description	Defines the destination parameter for threshold detector 1		
Mode	Regeneration		
Minimum	0.000	Maximum	59.999
Default	0.000	Units	
Type	16 Bit User Save	Update Rate	Drive reset read
Display Format	Standard	Decimal Places	3
Coding	RW, DE, PT, BU		

See *Threshold Detector 1 Output* (12.001).

Parameter	12.008 Variable Selector 1 Source 1		
Short description	Defines the 1st source parameter for variable selector 1		
Mode	Regeneration		
Minimum	0.000	Maximum	59.999
Default	0.000	Units	
Type	16 Bit User Save	Update Rate	Drive reset read
Display Format	Standard	Decimal Places	3
Coding	RW, PT, BU		

The variable selector functions are always active even if the source and destination are not routed to valid parameters. If a source is not a valid parameter then the source value is taken as 0. The update rate for each of the variable selector functions is always 4ms.

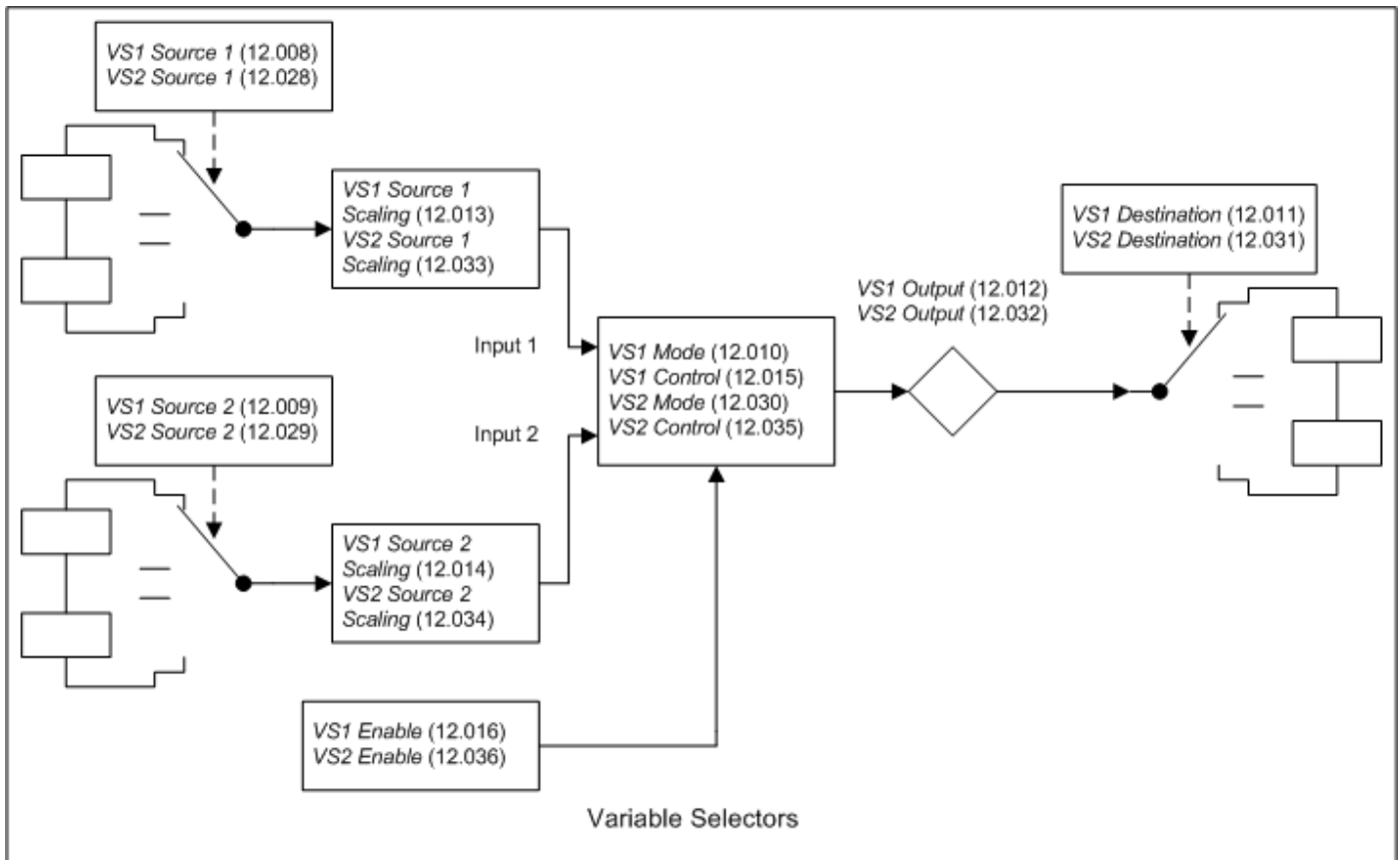

The following description is for variable selector 1, but variable selector 2 operates in the same way. The source parameters selected with *Variable Selector 1 Source 1* (12.008) and *Variable Selector 1 Source 2* (12.009) are converted to a percentage value, scaled with *Variable Selector 1 Source 1 Scaling* (12.013) and *Variable Selector 1 Source 2 Scaling* (12.014) respectively and then combined with a function defined by *Variable Selector 1 Mode* (12.010) to give *Variable Selector 1 Output* (12.012) as a percentage value. If *Variable Selector 1 Enable* (12.016) = 1 then the function operates normally. If *Variable Selector 1 Enable* (12.016) = 0 then *Variable Selector 1 Output* (12.012) = 0.00% and any states within the function are reset (i.e. the time constant function accumulator is held at zero). If the value of *Variable Selector 1 Mode* (12.010) is changed then all internal function state are also reset.

The table below shows the functions that can be selected with *Variable Selector 1 Mode* (12.010).

Variable Selector 1 Mode (12.010)	Variable Selector 1 Output (12.012)
0: Input 1	Input 1
1: Input 2	Input 2
2: Add	Input 1 + Input 2
3: Subtract	Input 1 - Input 2
4: Multiply	(Input 1 x Input 2) / 100.00%
5: Divide	(Input 1 x 100.00%) / Input 2
6: Time Const	Input 1 / (1 + τs) where τ = <i>Variable Selector 1 Control</i> (12.015) seconds
7: Ramp	Input 1 as an input to a linear ramp function where the time to ramp from 0.00% to 100.00% is defined by <i>Variable Selector 1 Control</i> (12.015) seconds
8: Modulus	Input1
9: Powers	If <i>Variable Selector 1 Control</i> (12.015) = 0.02 then Input ² / 100.00% Else if <i>Variable Selector 1 Control</i> (12.015) = 0.03 then Input ³ / 100.00% Else Input 1
10: Sectional	See description below

Sectional Controller

If *Variable Selector 1 Mode* (12.010) = 10 then the variable selector can be used to provide a sectional control function. (Variable selector 2 operates in the same way.) The sectional control function is intended to apply scaling and a speed offset to a 16 bit position value to generate a new 16 bit position value. The output can be used as an input to the Standard motion controller (Menu 13) and to generate an encoder simulation output (Menu 3).

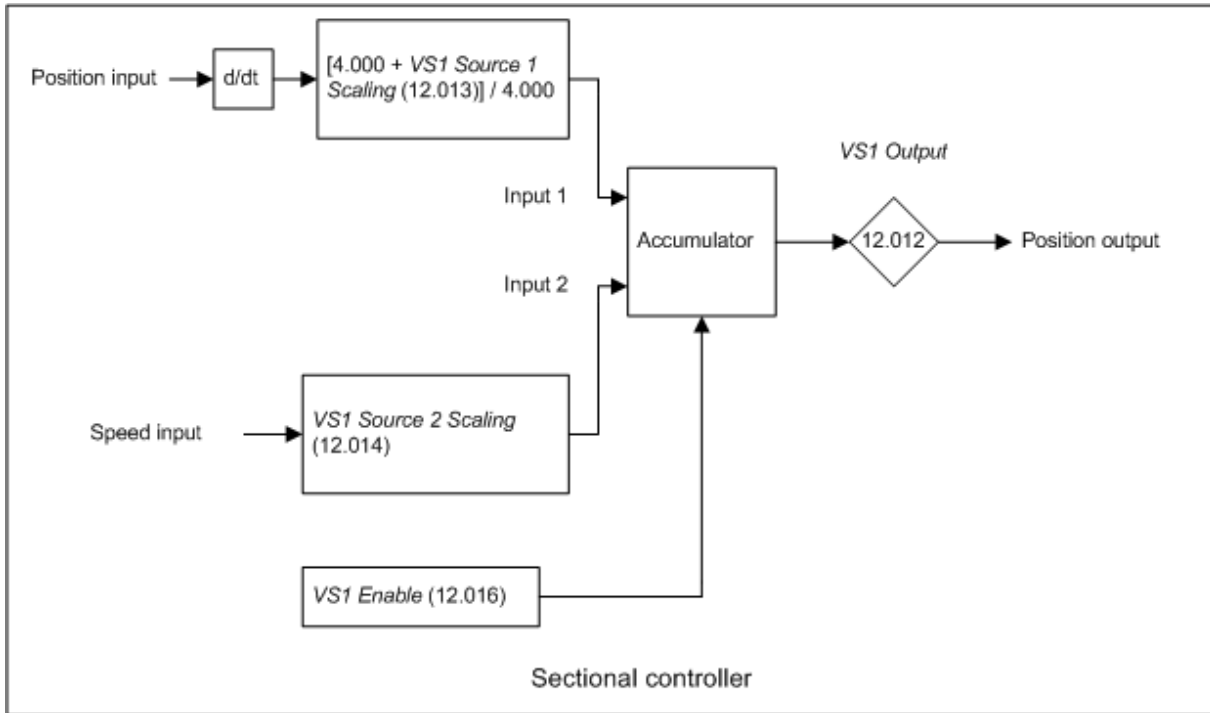

The position input is selected with *Variable Selector 1 Source 1* (12.008) and can be derived from any parameter. However, it is intended to be used with a position value that has a range from 0 to 65535 (e.g. *P1 Position* (03.029)). The input is scaled so that as *Variable Selector 1 Source 1 Scaling* (12.013) is changed between -4.000 and 4.000 so the proportion of the input position change added to the accumulator varies from 0.000 to 2.000 (i.e. the change of position input value is added without scaling if *Variable Selector 1 Source 1 Scaling* (12.013) = 0.000). The remainder from the scaling division is stored and then added at the next sample to maintain an exact ratio between the position input and the position output, provided the speed from source 2 is zero. The controller only takes the change of position from the input source parameter, and not the absolute value, so that when the controller is first made active the output does not jump to the source position, but only moves with any changes of source position after that point in time.

Although the sectional controller is intended to use a source parameter with a range from 0 to 65535, it is possible to use parameters with a different range provided the maximum is a power of two minus 1, i.e. $2^{31} - 1$. It should be noted that the change of position is scaled based on the maximum of the parameter, and so a signed position value such as *P1 Normalised Position* (03.058) which has a maximum that corresponds to half its range will give twice the change of position when compared to *P1 Position* (03.029). To counteract this effect the scaling applied to the change of position in the sectional controller should be set to 0.5.

The range of *Variable Selector 1 Output* (12.012) is 0.00% and 100.00%. Unlike other functions the value is not simply limited, but rolls under or over respectively. Although the output destination can be any parameter it is intended to be used with a position value that has a range from 0 to 65535.

The speed input defines a speed offset with a resolution of 0.1rpm. Full scale of the source parameter corresponds to 1000.0rpm. Scaling may be applied using *Variable Selector 1 Source 2 Scaling* (12.014) to give a full scale value up to 4000.0rpm. The speed input is added to the accumulator to move the output position forwards or backwards with respect to the position input.

The sample time for the variable selector is 4ms and the input or output position must not change by more than half a revolution over this time. Therefore the input or output speed must not exceed 7500rpm.

The diagram below shows an example of how the sectional controller function could be configured. The section input position is provided from the previous section via the P1 position feedback interface. The destination of the variable selector is the *Standard Motion Local Reference Position* (13.021) in the standard motion controller which is used to provide the speed reference and to control the local motor attached to the drive. The encoder simulation system is used to generate the section output to be fed into the next drive. The source for the encoder simulation is *Standard Motion Local Reference Position* (13.021).

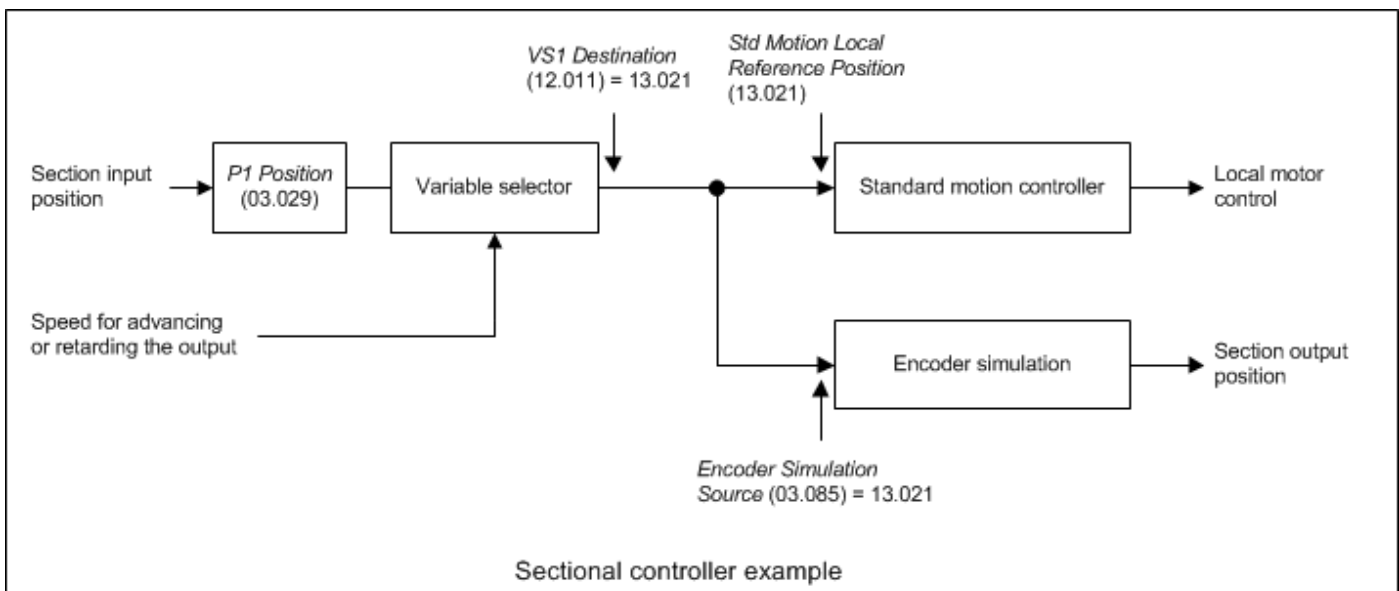

Parameter				12.009 Variable Selector 1 Source 2			
Short description				Defines the 2nd source parameter for variable selector 1			
Mode				Regeneration			
Minimum		0.000		Maximum		59.999	
Default		0.000		Units			
Type		16 Bit User Save		Update Rate		Drive reset read	
Display Format		Standard		Decimal Places		3	
Coding				RW, PT, BU			

See *Variable Selector 1 Source 1* (12.008).

Parameter				12.010 Variable Selector 1 Mode			
Short description				Defines the mode for variable selector 1			
Mode				Regeneration			
Minimum		0		Maximum		10	
Default		0		Units			
Type		8 Bit User Save		Update Rate		Background read	
Display Format		Standard		Decimal Places		0	
Coding				RW, TE			

Value	Text
0	Input 1
1	Input 2
2	Add
3	Subtract
4	Multiply
5	Divide
6	Time Const
7	Ramp
8	Modulus
9	Powers
10	Sectional

See *Variable Selector 1 Source 1* (12.008).

Parameter				12.011 Variable Selector 1 Destination			
Short description				Defines the destination parameter for variable selector 1			
Mode				Regeneration			
Minimum		0.000		Maximum		59.999	
Default		0.000		Units			
Type		16 Bit User Save		Update Rate		Drive reset read	
Display Format		Standard		Decimal Places		3	
Coding				RW, DE, PT, BU			

See *Variable Selector 1 Source 1* (12.008).

Parameter				12.012 Variable Selector 1 Output			
Short description				Displays the output of variable selector 1			
Mode				Regeneration			
Minimum		-100.00		Maximum		100.00	
Default				Units		%	
Type		16 Bit Volatile		Update Rate		4ms write	
Display Format		Standard		Decimal Places		2	
Coding				RO, ND, NC, PT			

See *Variable Selector 1 Source 1* (12.008).

Parameter				12.013 Variable Selector 1 Source 1 Scaling			
Short description				Defines the scaling for the 1st input for variable selector 1			
Mode				Regeneration			
Minimum		-4.000		Maximum		4.000	
Default		1.000		Units			
Type		16 Bit User Save		Update Rate		4ms read	
Display Format		Standard		Decimal Places		3	
Coding				RW			

See *Variable Selector 1 Source 1* (12.008).

Parameter	12.014 Variable Selector 1 Source 2 Scaling		
Short description	Defines the scaling for the 2nd input for variable selector 1		
Mode	Regeneration		
Minimum	-4.000	Maximum	4.000
Default	1.000	Units	
Type	16 Bit User Save	Update Rate	4ms read
Display Format	Standard	Decimal Places	3
Coding	RW		

See *Variable Selector 1 Source 1* (12.008).

Parameter	12.015 Variable Selector 1 Control		
Short description	Defines the control for variable selector 1		
Mode	Regeneration		
Minimum	0.00	Maximum	100.00
Default	0.00	Units	
Type	16 Bit User Save	Update Rate	4ms read
Display Format	Standard	Decimal Places	2
Coding	RW		

See *Variable Selector 1 Source 1* (12.008).

Parameter	12.016 Variable Selector 1 Enable		
Short description	Enables variable selector 1		
Mode	Regeneration		
Minimum	0	Maximum	1
Default	1	Units	
Type	1 Bit User Save	Update Rate	4ms read
Display Format	Standard	Decimal Places	0
Coding	RW, BU		

See *Variable Selector 1 Source 1* (12.008) for more details.

Variable Selector 1 Enable (12.016) and *Variable Selector 2 Enable* (12.036) have a default of 1 so that if these parameters are not used the variable selectors will still function.

Parameter	12.023 Threshold Detector 2 Source		
Short description	Defines the source parameter for threshold detector 2		
Mode	Regeneration		
Minimum	0.000	Maximum	59.999
Default	0.000	Units	
Type	16 Bit User Save	Update Rate	Drive reset read
Display Format	Standard	Decimal Places	3
Coding	RW, PT, BU		

See *Threshold Detector 1 Output* (12.001).

Parameter	12.024 Threshold Detector 2 Level		
Short description	Defines the reference level for threshold detector 2		
Mode	Regeneration		
Minimum	0.00	Maximum	100.00
Default	0.00	Units	
Type	16 Bit User Save	Update Rate	4ms read
Display Format	Standard	Decimal Places	2
Coding	RW		

See *Threshold Detector 1 Output* (12.001).

Parameter	12.025 Threshold Detector 2 Hysteresis		
Short description	Defines the hysteresis for threshold detector 2		
Mode	Regeneration		
Minimum	0.00	Maximum	25.00
Default	0.00	Units	
Type	16 Bit User Save	Update Rate	4ms read
Display Format	Standard	Decimal Places	2
Coding	RW		

See *Threshold Detector 1 Output* (12.001).

Parameter	12.026 Threshold Detector 2 Output Invert		
Short description	Set to 1 to invert the output of threshold detector 2		
Mode	Regeneration		
Minimum	0	Maximum	1
Default	0	Units	
Type	1 Bit User Save	Update Rate	4ms read
Display Format	Standard	Decimal Places	0
Coding	RW		

See *Threshold Detector 1 Output* (12.001).

Parameter	12.027 Threshold Detector 2 Destination		
Short description	Defines the destination parameter for threshold detector 2		
Mode	Regeneration		
Minimum	0.000	Maximum	59.999
Default	0.000	Units	
Type	16 Bit User Save	Update Rate	Drive reset read
Display Format	Standard	Decimal Places	3
Coding	RW, DE, PT, BU		

See *Threshold Detector 1 Output* (12.001).

Parameter	12.028 Variable Selector 2 Source 1		
Short description	Defines the 1st source parameter for variable selector 2		
Mode	Regeneration		
Minimum	0.000	Maximum	59.999
Default	0.000	Units	
Type	16 Bit User Save	Update Rate	Drive reset read
Display Format	Standard	Decimal Places	3
Coding	RW, PT, BU		

See *Variable Selector 1 Source 1* (12.008).

Parameter	12.029 Variable Selector 2 Source 2		
Short description	Defines the 2nd source parameter for variable selector 2		
Mode	Regeneration		
Minimum	0.000	Maximum	59.999
Default	0.000	Units	
Type	16 Bit User Save	Update Rate	Drive reset read
Display Format	Standard	Decimal Places	3
Coding	RW, PT, BU		

See *Variable Selector 1 Source 1* (12.008).

Parameter	12.030 Variable Selector 2 Mode		
Short description	Defines the mode for variable selector 2		
Mode	Regeneration		
Minimum	0	Maximum	10
Default	0	Units	
Type	8 Bit User Save	Update Rate	Background read
Display Format	Standard	Decimal Places	0
Coding	RW, TE		

Value	Text
0	Input 1
1	Input 2
2	Add
3	Subtract
4	Multiply
5	Divide
6	Time Const
7	Ramp
8	Modulus
9	Powers
10	Sectional

See *Variable Selector 1 Source 1* (12.008).

Parameter	12.031 Variable Selector 2 Destination		
Short description	Defines the destination parameter for variable selector 2		
Mode	Regeneration		
Minimum	0.000	Maximum	59.999
Default	0.000	Units	
Type	16 Bit User Save	Update Rate	Drive reset read
Display Format	Standard	Decimal Places	3
Coding	RW, DE, PT, BU		

See *Variable Selector 1 Source 1* (12.008).

Parameter	12.032 Variable Selector 2 Output		
Short description	Displays the output of variable selector 2		
Mode	Regeneration		
Minimum	-100.00	Maximum	100.00
Default		Units	%
Type	16 Bit Volatile	Update Rate	4ms write
Display Format	Standard	Decimal Places	2
Coding	RO, ND, NC, PT		

See *Variable Selector 1 Source 1* (12.008).

Parameter	12.033 Variable Selector 2 Source 1 Scaling		
Short description	Defines the scaling for the 1st input for variable selector 2		
Mode	Regeneration		
Minimum	-4.000	Maximum	4.000
Default	1.000	Units	
Type	16 Bit User Save	Update Rate	4ms read
Display Format	Standard	Decimal Places	3
Coding	RW		

See *Variable Selector 1 Source 1* (12.008).

Parameter	12.034 Variable Selector 2 Source 2 Scaling		
Short description	Defines the scaling for the 2nd input for variable selector 2		
Mode	Regeneration		
Minimum	-4.000	Maximum	4.000
Default	1.000	Units	
Type	16 Bit User Save	Update Rate	4ms read
Display Format	Standard	Decimal Places	3
Coding	RW		

Parameter	12.035 Variable Selector 2 Control		
Short description	Defines the control for variable selector 2		
Mode	Regeneration		
Minimum	0.00	Maximum	100.00
Default	0.00	Units	
Type	16 Bit User Save	Update Rate	4ms read
Display Format	Standard	Decimal Places	2
Coding	RW		

See *Variable Selector 1 Source 1* (12.008).

Parameter	12.036 Variable Selector 2 Enable		
Short description	Enables variable selector 2		
Mode	Regeneration		
Minimum	0	Maximum	1
Default	1	Units	
Type	1 Bit User Save	Update Rate	4ms read
Display Format	Standard	Decimal Places	0
Coding	RW, BU		

See *Variable Selector 1 Source 1* (12.008).

Menu 14 Single Line Descriptions – *User PID Controller*

Mode: Regeneration

Parameter		Range	Default	Type					
14.001	PID1 Output	±100.00 %		RO	Num	ND	NC	PT	
14.002	PID1 Feed-forwards Reference Source	0.000 to 59.999	0.000	RW	Num			PT	US
14.003	PID1 Reference Source	0.000 to 59.999	0.000	RW	Num			PT	US
14.004	PID1 Feedback Source	0.000 to 59.999	0.000	RW	Num			PT	US
14.005	PID1 Reference Invert	Off (0) or On (1)	Off (0)	RW	Bit				US
14.006	PID1 Feedback Invert	Off (0) or On (1)	Off (0)	RW	Bit				US
14.007	PID1 Reference Slew Rate	0.0 to 3200.0 s	0.0 s	RW	Num				US
14.008	PID1 Enable	Off (0) or On (1)	Off (0)	RW	Bit				US
14.009	PID1 Enable Source 1	0.000 to 59.999	0.000	RW	Num			PT	US
14.010	PID1 Proportional Gain	0.000 to 4.000	1.000	RW	Num				US
14.011	PID1 Integral Gain	0.000 to 4.000	0.500	RW	Num				US
14.012	PID1 Differential Gain	0.000 to 4.000	0.000	RW	Num				US
14.013	PID1 Output Upper Limit	0.00 to 100.00	100.00	RW	Num				US
14.014	PID1 Output Lower Limit	±100.00	-100.00	RW	Num				US
14.015	PID1 Output Scaling	0.000 to 4.000	1.000	RW	Num				US
14.016	PID1 Destination	0.000 to 59.999	0.000	RW	Num	DE		PT	US
14.017	PID1 Integral Hold	Off (0) or On (1)	Off (0)	RW	Bit				
14.018	PID1 Symmetrical Limit Enable	Off (0) or On (1)	Off (0)	RW	Bit				US
14.019	PID1 Feed-forwards Reference	±100.00 %		RO	Num	ND	NC	PT	
14.020	PID1 Reference	±100.00 %		RO	Num	ND	NC	PT	
14.021	PID1 Feedback	±100.00 %		RO	Num	ND	NC	PT	
14.022	PID1 Error	±100.00 %		RO	Num	ND	NC	PT	
14.023	PID1 Reference Scaling	0.000 to 4.000	1.000	RW	Num				US
14.024	PID1 Feedback Scaling	0.000 to 4.000	1.000	RW	Num				US
14.025	PID1 Digital Reference	±100.00 %	0.00 %	RW	Num				US
14.026	PID1 Digital Feedback	±100.00 %	0.00 %	RW	Num				US
14.027	PID1 Enable Source 2	0.000 to 59.999	0.000	RW	Num			PT	US
14.031	PID2 Output	±100.00 %		RO	Num	ND	NC	PT	
14.032	PID2 Feed-forwards Reference Source	0.000 to 59.999	0.000	RW	Num			PT	US
14.033	PID2 Reference Source	0.000 to 59.999	0.000	RW	Num			PT	US
14.034	PID2 Feedback Source	0.000 to 59.999	0.000	RW	Num			PT	US
14.035	PID2 Reference Invert	Off (0) or On (1)	Off (0)	RW	Bit				US
14.036	PID2 Feedback Invert	Off (0) or On (1)	Off (0)	RW	Bit				US
14.037	PID2 Reference Slew Rate Limit	0.0 to 3200.0 s	0.0 s	RW	Num				US
14.038	PID2 Enable	Off (0) or On (1)	Off (0)	RW	Bit				US
14.039	PID2 Enable Source 1	0.000 to 59.999	0.000	RW	Num			PT	US
14.040	PID2 Proportional Gain	0.000 to 4.000	1.000	RW	Num				US
14.041	PID2 Integral Gain	0.000 to 4.000	0.500	RW	Num				US
14.042	PID2 Differential Gain	0.000 to 4.000	0.000	RW	Num				US
14.043	PID2 Output Upper Limit	0.00 to 100.00	100.00	RW	Num				US
14.044	PID2 Output Lower Limit	±100.00	-100.00	RW	Num				US
14.045	PID2 Output Scaling	0.000 to 4.000	1.000	RW	Num				US
14.046	PID2 Destination	0.000 to 59.999	0.000	RW	Num	DE		PT	US
14.047	PID2 Integral Hold	Off (0) or On (1)	Off (0)	RW	Bit				
14.048	PID2 Symmetrical Limit Enable	Off (0) or On (1)	Off (0)	RW	Bit				US
14.049	PID2 Feed-forwards Reference	±100.00 %		RO	Num	ND	NC	PT	
14.050	PID2 Reference	±100.00 %		RO	Num	ND	NC	PT	
14.051	PID2 Feedback	±100.00 %		RO	Num	ND	NC	PT	
14.052	PID2 Error	±100.00 %		RO	Num	ND	NC	PT	
14.053	PID2 Reference Scaling	0.000 to 4.000	1.000	RW	Num				US
14.054	PID2 Feedback Scaling	0.000 to 4.000	1.000	RW	Num				US
14.055	PID2 Digital Reference	±100.00 %	0.00 %	RW	Num				US
14.056	PID2 Digital Feedback	±100.00 %	0.00 %	RW	Num				US
14.057	PID2 Enable Source 2	0.000 to 59.999	0.000	RW	Num			PT	US
14.058	PID1 Feedback Output Scaling	0.000 to 4.000	1.000	RW	Num				US
14.059	PID1 Mode Selector	Fbk1 (0), Fbk2 (1), Fbk1 + Fbk2 (2), Min Fbk (3), Max Fbk (4), Av Fbk (5), Min Error (6), Max Error (7)	Fbk1 (0)	RW	Txt				US
14.060	PID1 Feedback Square Root Enable 1	Off (0) or On (1)	Off (0)	RW	Bit				US
14.061	PID2 Feedback Square Root Enable	Off (0) or On (1)	Off (0)	RW	Bit				US
14.062	PID1 Feedback Square Root Enable 2	Off (0) or On (1)	Off (0)	RW	Bit				US

RW	Read / Write	RO	Read-only	Bit	Bit parameter	Txt	Text string	Date	Date parameter	Time	Time parameter
Chr	Character parameter	Bin	Binary parameter	IP	IP address	Mac	MAC address	Ver	Version number	SMP	Slot, menu, parameter
Num	Number parameter	DE	Destination	ND	No default value	RA	Rating dependent	NC	Non-copyable	PT	Protected
FI	Filtered	US	User save	PS	Power-down save						

Menu 14 – User PID Controller

Mode: Regeneration

Parameter	14.001 PID1 Output		
Short description	Displays the output for PID1		
Mode	Regeneration		
Minimum	-100.00	Maximum	100.00
Default		Units	%
Type	16 Bit Volatile	Update Rate	4ms write
Display Format	Standard	Decimal Places	2
Coding	RO, ND, NC, PT		

Controller

The controller section for the PID controllers is shown in the introduction. The structure of PID controller 1 shown in the introduction is when *PID1 Mode Selector* (14.059) = 0, *PID1 Feedback Output Scaling* (14.058) = 1.000, and *PID1 Feedback Square Root Enable 2* (14.062) = 0. The additional features provided by these parameters are not available for PID controller 2, and so this controller always has the structure shown. If the combined enable is inactive then all internal states are held at zero and the destination parameter will be defined by *PID1 Feed-forwards Reference* (14.019) alone. If the enable is active the PID controller is active even if the destination is not routed to a valid parameter or to 0.000. It should be noted that if either of the enable sources is routed to 0.000 or to a non-valid parameter the source value is taken as 1, therefore with default settings, *PID1 Enable Source 1* (14.009) = 0.000 and *PID1 Enable Source 2* (14.027) = 0.000, the PID controller can be enabled by simply setting *PID1 Enable* (14.008).

PID1 Error (14.022) is the difference between the reference and feedback produced by the reference and feedback systems described in the previous sections. The PID controller output is defined as follows:

$$PID1\ Output\ (14.001) = PID1\ Error\ (14.022) \times [Kp + Ki/s + sKd/(0.064s + 1)]$$

$$Kp = PID1\ Proportional\ Gain\ (14.010)$$

$$Ki = PID1\ Integral\ Gain\ (14.011)$$

$$Kd = PID1\ Differential\ Gain\ (14.012)$$

Therefore:

1. If *PID1 Error* (14.022) = 100.00% the proportional term gives a value of 100.00% if *PID1 Proportional Gain* (14.010) = 1.000.
2. If *PID1 Error* (14.022) = 100.00% the integral term gives a value that increases linearly by 100.00% per second if *PID1 Integral Gain* (14.011) = 1.000.
3. If *PID1 Error* (14.022) increases linearly by 100.00% per second the differential term gives a value of 100.00% if *PID1 Differential Gain* (14.012) = 1.000. (A filter with a time constant of 64ms is provided on the differential gain to reduce the noise produced by this term.)

The output may be limited to a range that is less than the maximum range of *PID1 Output* (14.001) using *PID1 Output Upper Limit* (14.013) and *PID1 Output Lower Limit* (14.014). If *PID1 Output Lower Limit* (14.014) > *PID1 Output Upper Limit* (14.013) then the output is held at the value defined by *PID1 Output Upper Limit* (14.013). If *PID1 Symmetrical Limit Enable* (14.018) = 1 then the lower limit = -(*PID1 Output Upper Limit* (14.013)). If the output reaches either of these limits the integral term accumulator is frozen until the output moves away from the limit to prevent integral wind-up. The integral hold function can also be enabled by the user by setting *PID1 Integral Hold* (14.017) = 1.

PID1 Output Scaling (14.015) can be used to scale the output, which is limited to a range from -100.00% to 100.00% after this function. The output is then added to *PID1 Feed-forwards Reference* (14.019) and is again limited to the range from -100.00% to 100.00% before being routed to the destination defined by *PID1 Destination* (14.016).

Parameter	14.002 PID1 Feed-forwards Reference Source		
Short description	Defines the input source for the feed-forwards reference source for PID1		
Mode	Regeneration		
Minimum	0.000	Maximum	59.999
Default	0.000	Units	
Type	16 Bit User Save	Update Rate	Drive reset read
Display Format	Standard	Decimal Places	3
Coding	RW, PT, BU		

See *PID1 Output* (14.001).

Parameter	14.003 PID1 Reference Source		
Short description	Defines the input source for the reference for PID1		
Mode	Regeneration		
Minimum	0.000	Maximum	59.999
Default	0.000	Units	
Type	16 Bit User Save	Update Rate	Drive reset read
Display Format	Standard	Decimal Places	3
Coding	RW, PT, BU		

The reference section for the PID controllers is shown in the introduction. The pre-sleep boost control is only included in PID controller 1. The reference

sections are always active even if the PID controller itself is disabled or the reference sources are not routed to valid parameters. If a reference source is not a valid parameter or is 0.000 then the value is taken as zero.

The reference is the sum of the reference source, the *PID1 Digital Reference* (14.025) and the *PID1 Pre-sleep Boost Level* (14.028) when it is active. The result is multiplied by *PID1 Reference Scaling* (14.023) and then limited to +/-100.00%. The reference can then be inverted if required (*PID1 Reference Invert* (14.005) = 1) and then a slew rate limit is applied with *PID1 Reference Slew Rate* (14.007). This limits the maximum rate of change so that a change from 0.00 to 100.00% takes the time given in *PID1 Reference Slew Rate* (14.007).

Sleep mode is used to stop the motor if the frequency or speed reference falls below a specified level so that the system does not run inefficiently at low speeds (see *Sleep / Wake Threshold* (06.053)). If the frequency or speed reference is controlled by PID controller 1 then the PID controller feedback will fall when sleep mode becomes active because the motor has stopped. The PID controller output will rise again above the sleep/wake threshold and the motor will restart. To minimise the number of transitions into and out of sleep mode the sleep condition can be delayed and an increased reference applied during this period by setting *PID1 Pre-sleep Boost Level* (14.028) to a non-zero value. When *Sleep Required* (06.056) = 1 the *PID1 Pre-sleep Boost Level* (14.028) is added to the reference until *PID1 Error* (14.022) is reduced below zero or until this additional reference has been applied for *PID1 Maximum Boost Time* (14.029). This system is only intended for applications where PID controller 1 alone is used to control the motor frequency or speed via the Menu 1 reference system and the motor rotates in the positive direction under normal conditions. When the PID output first falls below the *Sleep / Wake Threshold* (06.053) it is possible for *PID1 Error* (14.022) to be negative because of a positive value remaining in the integral accumulator. To allow the error to become positive so that the boost period is not terminated immediately, the *PID1 Pre-sleep Boost Level* (14.028) is applied for a minimum of 100ms before the end of the boost period can be terminated because *PID1 Error* (14.022) is greater than or equal to zero.

Parameter	14.004 PID1 Feedback Source		
Short description	Defines the input source for the feedback for PID1		
Mode	Regeneration		
Minimum	0.000	Maximum	59.999
Default	0.000	Units	
Type	16 Bit User Save	Update Rate	Drive reset read
Display Format	Standard	Decimal Places	3
Coding	RW, PT, BU		

Feedback

The feedback section for the PID controllers is shown in the introduction. The feedback sections are always active even if the PID controller itself is disabled or the feedback sources are not routed to valid parameters. If a reference source is not a valid parameter or is 0.000 then the value is taken as zero.

The feedback is the sum of the feedback source and the *PID1 Digital Feedback* (14.026). The result is multiplied by *PID1 Feedback Scaling* (14.024) and then limited to +/-100.00%. A square root function can be applied (*PID1 Feedback Square Root Enable 1* (14.060) = 1) and the feedback can then be inverted if required (*PID1 Feedback Invert* (14.006) = 1). The square root function is defined as follows.

Square root function output = Sign(Input) x 100.00% x $\sqrt{(|\text{Input}| / 100.00\%)}$

where Sign(Input) = 1 if Input ≥ 0 or -1 otherwise

The square root function is useful in applications where the PID controller is operating with air flow as its reference and feedback and the motor is controlling a fan. It is easier to use a pressure transducer than a flow transducer, and so the feedback from the transducer needs to be converted from pressure to flow. As flow = Constant x $\sqrt{\text{Pressure}}$ the square root function can be used in the conversion.

Parameter	14.005 PID1 Reference Invert		
Short description	Set to 1 to invert PID1 reference		
Mode	Regeneration		
Minimum	0	Maximum	1
Default	0	Units	
Type	1 Bit User Save	Update Rate	4ms read
Display Format	Standard	Decimal Places	0
Coding	RW		

See *PID1 Reference Source* (14.003).

Parameter	14.006 PID1 Feedback Invert		
Short description	Set to 1 to invert the PID1 feedback		
Mode	Regeneration		
Minimum	0	Maximum	1
Default	0	Units	
Type	1 Bit User Save	Update Rate	4ms read
Display Format	Standard	Decimal Places	0
Coding	RW		

See *PID1 Feedback Source* (14.004).

Parameter	14.007 PID1 Reference Slew Rate		
Short description	Defines the rate in change of output for PID1		
Mode	Regeneration		
Minimum	0.0	Maximum	3200.0
Default	0.0	Units	s
Type	16 Bit User Save	Update Rate	Background read
Display Format	Standard	Decimal Places	1
Coding	RW		

See *PID1 Reference Source* (14.003).

Parameter	14.008 PID1 Enable		
Short description	Enables the use of PID1		
Mode	Regeneration		
Minimum	0	Maximum	1
Default	0	Units	
Type	1 Bit User Save	Update Rate	4ms read
Display Format	Standard	Decimal Places	0
Coding	RW		

See *PID1 Output* (14.001).

Parameter	14.009 PID1 Enable Source 1		
Short description	Defines the input source for enabling PID1		
Mode	Regeneration		
Minimum	0.000	Maximum	59.999
Default	0.000	Units	
Type	16 Bit User Save	Update Rate	Drive reset read
Display Format	Standard	Decimal Places	3
Coding	RW, PT, BU		

See *PID1 Output* (14.001).

Parameter	14.010 PID1 Proportional Gain		
Short description	Defines the Kp gain used for PID1		
Mode	Regeneration		
Minimum	0.000	Maximum	4.000
Default	1.000	Units	
Type	16 Bit User Save	Update Rate	Background read
Display Format	Standard	Decimal Places	3
Coding	RW		

See *PID1 Output* (14.001).

Parameter	14.011 PID1 Integral Gain		
Short description	Defines the Ki gain used for PID1		
Mode	Regeneration		
Minimum	0.000	Maximum	4.000
Default	0.500	Units	
Type	16 Bit User Save	Update Rate	Background read
Display Format	Standard	Decimal Places	3
Coding	RW		

See *PID1 Output* (14.001).

Parameter	14.012 PID1 Differential Gain		
Short description	Defines the Kd gain used for PID1		
Mode	Regeneration		
Minimum	0.000	Maximum	4.000
Default	0.000	Units	
Type	16 Bit User Save	Update Rate	Background read
Display Format	Standard	Decimal Places	3
Coding	RW		

See *PID1 Output* (14.001).

Parameter	14.013 PID1 Output Upper Limit		
Short description	Defines the maximum value of the output for PID1		
Mode	Regeneration		
Minimum	0.00	Maximum	100.00
Default	100.00	Units	
Type	16 Bit User Save	Update Rate	4ms read
Display Format	Standard	Decimal Places	2
Coding	RW		

See *PID1 Output* (14.001).

Parameter	14.014 PID1 Output Lower Limit		
Short description	Defines the minimum value of the output for PID1		
Mode	Regeneration		
Minimum	-100.00	Maximum	100.00
Default	-100.00	Units	
Type	16 Bit User Save	Update Rate	4ms read
Display Format	Standard	Decimal Places	2
Coding	RW		

See *PID1 Output* (14.001).

Parameter	14.015 PID1 Output Scaling		
Short description	Defines the scaling factor of the output for PID1		
Mode	Regeneration		
Minimum	0.000	Maximum	4.000
Default	1.000	Units	
Type	16 Bit User Save	Update Rate	4ms read
Display Format	Standard	Decimal Places	3
Coding	RW		

See *PID1 Output* (14.001).

Parameter	14.016 PID1 Destination		
Short description	Defines the output parameter for PID1		
Mode	Regeneration		
Minimum	0.000	Maximum	59.999
Default	0.000	Units	
Type	16 Bit User Save	Update Rate	Drive reset read
Display Format	Standard	Decimal Places	3
Coding	RW, DE, PT, BU		

See *PID1 Output* (14.001).

Parameter	14.017 PID1 Integral Hold		
Short description	Enables the integral hold function for PID1		
Mode	Regeneration		
Minimum	0	Maximum	1
Default	0	Units	
Type	1 Bit Volatile	Update Rate	4ms read
Display Format	Standard	Decimal Places	0
Coding	RW		

See *PID1 Output* (14.001).

Parameter	14.018 PID1 Symmetrical Limit Enable		
Short description	Enables the symmetrical limit for PID1		
Mode	Regeneration		
Minimum	0	Maximum	1
Default	0	Units	
Type	1 Bit User Save	Update Rate	Background read
Display Format	Standard	Decimal Places	0
Coding	RW		

See *PID1 Output* (14.001).

Parameter	14.019 PID1 Feed-forwards Reference		
Short description	Displays the value of the feed-forwards reference for PID1		
Mode	Regeneration		
Minimum	-100.00	Maximum	100.00
Default		Units	%
Type	16 Bit Volatile	Update Rate	4ms write
Display Format	Standard	Decimal Places	2
Coding	RO, ND, NC, PT		

See *PID1 Output* (14.001).

Parameter	14.020 PID1 Reference		
Short description	Displays the value of the reference for PID1		
Mode	Regeneration		
Minimum	-100.00	Maximum	100.00
Default		Units	%
Type	16 Bit Volatile	Update Rate	4ms write
Display Format	Standard	Decimal Places	2
Coding	RO, ND, NC, PT		

See *PID1 Reference Source* (14.003).

Parameter	14.021 PID1 Feedback		
Short description	Displays the value of the feedback for PID1		
Mode	Regeneration		
Minimum	-100.00	Maximum	100.00
Default		Units	%
Type	16 Bit Volatile	Update Rate	4ms write
Display Format	Standard	Decimal Places	2
Coding	RO, ND, NC, PT		

See *PID1 Feedback Source* (14.004).

Parameter	14.022 PID1 Error		
Short description	Displays the value of the error for PID1		
Mode	Regeneration		
Minimum	-100.00	Maximum	100.00
Default		Units	%
Type	16 Bit Volatile	Update Rate	4ms write
Display Format	Standard	Decimal Places	2
Coding	RO, ND, NC, PT		

See *PID1 Output* (14.001).

Parameter	14.023 PID1 Reference Scaling		
Short description	Defines the scaling factor for the reference for PID1		
Mode	Regeneration		
Minimum	0.000	Maximum	4.000
Default	1.000	Units	
Type	16 Bit User Save	Update Rate	4ms read
Display Format	Standard	Decimal Places	3
Coding	RW		

See *PID1 Reference Source* (14.003).

Parameter	14.024 PID1 Feedback Scaling		
Short description	Defines the scaling factor of the feedback for PID1		
Mode	Regeneration		
Minimum	0.000	Maximum	4.000
Default	1.000	Units	
Type	16 Bit User Save	Update Rate	4ms read
Display Format	Standard	Decimal Places	3
Coding	RW		

See *PID1 Feedback Source* (14.004).

Parameter	14.025 PID1 Digital Reference		
Short description	Defines the value of the digital reference for PID1		
Mode	Regeneration		
Minimum	-100.00	Maximum	100.00
Default	0.00	Units	%
Type	16 Bit User Save	Update Rate	4ms read
Display Format	Standard	Decimal Places	2
Coding	RW		

See *PID1 Reference Source* (14.003).

Parameter	14.026 PID1 Digital Feedback		
Short description	Defines the value of the digital feedback for PID1		
Mode	Regeneration		
Minimum	-100.00	Maximum	100.00
Default	0.00	Units	%
Type	16 Bit User Save	Update Rate	4ms read
Display Format	Standard	Decimal Places	2
Coding	RW		

See *PID1 Feedback Source* (14.004).

Parameter	14.027 PID1 Enable Source 2		
Short description	Defines the input source for enabling PID1		
Mode	Regeneration		
Minimum	0.000	Maximum	59.999
Default	0.000	Units	
Type	16 Bit User Save	Update Rate	Drive reset read
Display Format	Standard	Decimal Places	3
Coding	RW, PT, BU		

See *PID1 Output* (14.001).

Parameter	14.031 PID2 Output		
Short description	Displays the output for PID2		
Mode	Regeneration		
Minimum	-100.00	Maximum	100.00
Default		Units	%
Type	16 Bit Volatile	Update Rate	4ms write
Display Format	Standard	Decimal Places	2
Coding	RO, ND, NC, PT		

See *PID1 Output* (14.001).

Parameter	14.032 PID2 Feed-forwards Reference Source		
Short description	Defines the input source for the feed-forwards reference source for PID2		
Mode	Regeneration		
Minimum	0.000	Maximum	59.999
Default	0.000	Units	
Type	16 Bit User Save	Update Rate	Drive reset read
Display Format	Standard	Decimal Places	3
Coding	RW, PT, BU		

See *PID1 Feed-forwards Reference Source* (14.002).

Parameter	14.033 PID2 Reference Source		
Short description	Defines the input source for the reference for PID2		
Mode	Regeneration		
Minimum	0.000	Maximum	59.999
Default	0.000	Units	
Type	16 Bit User Save	Update Rate	Drive reset read
Display Format	Standard	Decimal Places	3
Coding	RW, PT, BU		

See *PID1 Reference Source* (14.003).

Parameter	14.034 PID2 Feedback Source		
Short description	Defines the input source for the feedback for PID2		
Mode	Regeneration		
Minimum	0.000	Maximum	59.999
Default	0.000	Units	
Type	16 Bit User Save	Update Rate	Drive reset read
Display Format	Standard	Decimal Places	3
Coding	RW, PT, BU		

See *PID1 Feedback Source* (14.004).

Parameter	14.035 PID2 Reference Invert		
Short description	Set to 1 to invert PID2 reference		
Mode	Regeneration		
Minimum	0	Maximum	1
Default	0	Units	
Type	1 Bit User Save	Update Rate	4ms read
Display Format	Standard	Decimal Places	0
Coding	RW		

See *PID1 Reference Invert* (14.005).

Parameter	14.036 PID2 Feedback Invert		
Short description	Set to 1 to invert PID2 feedback		
Mode	Regeneration		
Minimum	0	Maximum	1
Default	0	Units	
Type	1 Bit User Save	Update Rate	4ms read
Display Format	Standard	Decimal Places	0
Coding	RW		

See *PID1 Feedback Invert* (14.006).

Parameter	14.037 PID2 Reference Slew Rate Limit		
Short description	Defines the rate in change of output for PID2		
Mode	Regeneration		
Minimum	0.0	Maximum	3200.0
Default	0.0	Units	s
Type	16 Bit User Save	Update Rate	Background read
Display Format	Standard	Decimal Places	1
Coding	RW, BU		

See *PID1 Reference Slew Rate* (14.007).

Parameter	14.038 PID2 Enable		
Short description	Enables the use of PID2		
Mode	Regeneration		
Minimum	0	Maximum	1
Default	0	Units	
Type	1 Bit User Save	Update Rate	4ms read
Display Format	Standard	Decimal Places	0
Coding	RW		

See *PID1 Enable* (14.008).

Parameter	14.039 PID2 Enable Source 1		
Short description	Defines the input source for enabling PID2		
Mode	Regeneration		
Minimum	0.000	Maximum	59.999
Default	0.000	Units	
Type	16 Bit User Save	Update Rate	Drive reset read
Display Format	Standard	Decimal Places	3
Coding	RW, PT, BU		

See *PID1 Enable Source 1* (14.009).

Parameter	14.040 PID2 Proportional Gain		
Short description	Defines the Kp gain used for PID2		
Mode	Regeneration		
Minimum	0.000	Maximum	4.000
Default	1.000	Units	
Type	16 Bit User Save	Update Rate	Background read
Display Format	Standard	Decimal Places	3
Coding	RW, BU		

See *PID1 Proportional Gain* (14.010).

Parameter	14.041 PID2 Integral Gain		
Short description	Defines the Ki gain used for PID2		
Mode	Regeneration		
Minimum	0.000	Maximum	4.000
Default	0.500	Units	
Type	16 Bit User Save	Update Rate	Background read
Display Format	Standard	Decimal Places	3
Coding	RW, BU		

See *PID1 Integral Gain* (14.011).

Parameter	14.042 PID2 Differential Gain		
Short description	Defines the Kd gain used for PID2		
Mode	Regeneration		
Minimum	0.000	Maximum	4.000
Default	0.000	Units	
Type	16 Bit User Save	Update Rate	Background read
Display Format	Standard	Decimal Places	3
Coding	RW, BU		

See *PID1 Differential Gain* (14.012).

Parameter	14.043 PID2 Output Upper Limit		
Short description	Defines the maximum value of the output for PID2		
Mode	Regeneration		
Minimum	0.00	Maximum	100.00
Default	100.00	Units	
Type	16 Bit User Save	Update Rate	4ms read
Display Format	Standard	Decimal Places	2
Coding	RW, BU		

See *PID1 Output Upper Limit* (14.013).

Parameter	14.044 PID2 Output Lower Limit		
Short description	Defines the minimum value of the output for PID2		
Mode	Regeneration		
Minimum	-100.00	Maximum	100.00
Default	-100.00	Units	
Type	16 Bit User Save	Update Rate	4ms read
Display Format	Standard	Decimal Places	2
Coding	RW		

See *PID1 Output Lower Limit* (14.014).

Parameter	14.045 PID2 Output Scaling		
Short description	Defines the scaling factor of the output for PID2		
Mode	Regeneration		
Minimum	0.000	Maximum	4.000
Default	1.000	Units	
Type	16 Bit User Save	Update Rate	4ms read
Display Format	Standard	Decimal Places	3
Coding	RW, BU		

See *PID1 Output Scaling* (14.015).

Parameter	14.046 PID2 Destination		
Short description	Defines the output parameter for PID2		
Mode	Regeneration		
Minimum	0.000	Maximum	59.999
Default	0.000	Units	
Type	16 Bit User Save	Update Rate	Drive reset read
Display Format	Standard	Decimal Places	3
Coding	RW, DE, PT, BU		

See *PID1 Destination* (14.016).

Parameter	14.047 PID2 Integral Hold		
Short description	Enables the integral hold function for PID2		
Mode	Regeneration		
Minimum	0	Maximum	1
Default	0	Units	
Type	1 Bit Volatile	Update Rate	4ms read
Display Format	Standard	Decimal Places	0
Coding	RW		

See *PID1 Integral Hold* (14.017).

Parameter	14.048 PID2 Symmetrical Limit Enable		
Short description	Enables the symmetrical limit for PID2		
Mode	Regeneration		
Minimum	0	Maximum	1
Default	0	Units	
Type	1 Bit User Save	Update Rate	Background read
Display Format	Standard	Decimal Places	0
Coding	RW		

See *PID1 Symmetrical Limit Enable* (14.018).

Parameter	14.049 PID2 Feed-forwards Reference		
Short description	Displays the value of the feed-forwards reference for PID2		
Mode	Regeneration		
Minimum	-100.00	Maximum	100.00
Default		Units	%
Type	16 Bit Volatile	Update Rate	4ms write
Display Format	Standard	Decimal Places	2
Coding	RO, ND, NC, PT		

See *PID1 Feed-forwards Reference* (14.019).

Parameter	14.050 PID2 Reference		
Short description	Displays the value of the reference for PID2		
Mode	Regeneration		
Minimum	-100.00	Maximum	100.00
Default		Units	%
Type	16 Bit Volatile	Update Rate	4ms write
Display Format	Standard	Decimal Places	2
Coding	RO, ND, NC, PT		

See *PID1 Reference* (14.020).

Parameter	14.051 PID2 Feedback		
Short description	Displays the value of the feedback for PID2		
Mode	Regeneration		
Minimum	-100.00	Maximum	100.00
Default		Units	%
Type	16 Bit Volatile	Update Rate	4ms write
Display Format	Standard	Decimal Places	2
Coding	RO, ND, NC, PT		

See *PID1 Feedback* (14.021).

Parameter	14.052 PID2 Error		
Short description	Displays the value of the error for PID2		
Mode	Regeneration		
Minimum	-100.00	Maximum	100.00
Default		Units	%
Type	16 Bit Volatile	Update Rate	4ms write
Display Format	Standard	Decimal Places	2
Coding	RO, ND, NC, PT		

See *PID1 Error* (14.022).

Parameter	14.053 PID2 Reference Scaling		
Short description	Defines the scaling factor for the reference for PID2		
Mode	Regeneration		
Minimum	0.000	Maximum	4.000
Default	1.000	Units	
Type	16 Bit User Save	Update Rate	4ms read
Display Format	Standard	Decimal Places	3
Coding	RW, BU		

See *PID1 Reference Scaling* (14.023).

Parameter	14.054 PID2 Feedback Scaling		
Short description	Defines the scaling factor of the feedback for PID2		
Mode	Regeneration		
Minimum	0.000	Maximum	4.000
Default	1.000	Units	
Type	16 Bit User Save	Update Rate	4ms read
Display Format	Standard	Decimal Places	3
Coding	RW, BU		

See *PID1 Feedback Scaling* (14.024).

Parameter	14.055 PID2 Digital Reference		
Short description	Defines the value of the digital reference for PID2		
Mode	Regeneration		
Minimum	-100.00	Maximum	100.00
Default	0.00	Units	%
Type	16 Bit User Save	Update Rate	4ms read
Display Format	Standard	Decimal Places	2
Coding	RW		

See *PID1 Digital Reference* (14.025).

Parameter	14.056 PID2 Digital Feedback		
Short description	Defines the value of the digital feedback for PID2		
Mode	Regeneration		
Minimum	-100.00	Maximum	100.00
Default	0.00	Units	%
Type	16 Bit User Save	Update Rate	4ms read
Display Format	Standard	Decimal Places	2
Coding	RW		

See *PID1 Digital Feedback* (14.026).

Parameter	14.057 PID2 Enable Source 2		
Short description	Defines the input source for enabling PID2		
Mode	Regeneration		
Minimum	0.000	Maximum	59.999
Default	0.000	Units	
Type	16 Bit User Save	Update Rate	Drive reset read
Display Format	Standard	Decimal Places	3
Coding	RW, PT, BU		

See *PID1 Enable Source 2* (14.027).

Parameter	14.058 PID1 Feedback Output Scaling		
Short description	Defines the scaling factor of the output feedback for PID1		
Mode	Regeneration		
Minimum	0.000	Maximum	4.000
Default	1.000	Units	
Type	16 Bit User Save	Update Rate	4ms read
Display Format	Standard	Decimal Places	3
Coding	RW, BU		

PID1 alternative feedback and error selection

The description given in *PID1 Output* (14.001) assumed that *PID1 Mode Selector* (14.059) = 0 so that PID controller 1 uses its own feedback (FBK1). It is possible to select alternative configurations that allow various combinations of feedback or error from either PID controller to be used as shown below.

PID1 Mode Selector (14.059) can be used to select the feedback and error as shown in the table below. It should be noted that PID controller 2 will operate normally even when its feedback or error has been selected for PID controller 1. However, if *PID1 Mode Selector* (14.059) is non-zero PID controller 2 enable is controlled directly by the enable state of PID controller 1.

PID1 Mode Selector (14.059)	Feedback	Error
0: Fbk1	FBK1	ERR1
1: Fbk2	FBK2	ERR1
2: Fbk1 + Fbk2	FBK1 + FBK2	ERR1
3: Min Fbk	Lowest of FBK1 or FBK2	ERR1
4: Max Fbk	Highest of FBK1 or FBK2	ERR1
5: Av Fbk	(FBK1 + FBK2) / 2	ERR1
6: Min Error	FBK1	If ERR1 ≤ ERR2 then ERR1 Else ERR2
7: Max Error	FBK1	If ERR1 ≥ ERR2 then ERR1 Else ERR2

PID1 Feedback Output Scaling (14.058) can then be used to scale the results. *PID1 Feedback Square Root Enable 2* (14.062) can be used in converting the output of the combined feedback from pressure to flow. It is easier to use a pressure transducer than a flow transducer, and so the feedback from the transducer needs to be converted from pressure to flow. As flow = Constant x √Pressure the square root function can be used in the conversion.

Parameter	14.059 PID1 Mode Selector		
Short description	Defines the mode of PID1		
Mode	Regeneration		
Minimum	0	Maximum	7
Default	0	Units	
Type	8 Bit User Save	Update Rate	Background read
Display Format	Standard	Decimal Places	0
Coding	RW, TE, BU		

Value	Text
0	Fbk1
1	Fbk2
2	Fbk1 + Fbk2
3	Min Fbk
4	Max Fbk
5	Av Fbk
6	Min Error
7	Max Error

See *PID1 Feedback Output Scaling* (14.058).

Parameter	14.060 PID1 Feedback Square Root Enable 1		
Short description	Enables the square root function of PID1		
Mode	Regeneration		
Minimum	0	Maximum	1
Default	0	Units	
Type	1 Bit User Save	Update Rate	4ms read
Display Format	Standard	Decimal Places	0
Coding	RW		

See *PID1 Feedback Source* (14.004).

Parameter	14.061 <i>PID2 Feedback Square Root Enable</i>		
Short description	Enables the square root function of PID2		
Mode	Regeneration		
Minimum	0	Maximum	1
Default	0	Units	
Type	1 Bit User Save	Update Rate	4ms read
Display Format	Standard	Decimal Places	0
Coding	RW		

See *PID1 Feedback Square Root Enable 1* (14.060)

Parameter	14.062 <i>PID1 Feedback Square Root Enable 2</i>		
Short description	Enables the square root function of PID1		
Mode	Regeneration		
Minimum	0	Maximum	1
Default	0	Units	
Type	1 Bit User Save	Update Rate	4ms read
Display Format	Standard	Decimal Places	0
Coding	RW		

See *PID1 Feedback Output Scaling* (14.058).

Menu 13 Single Line Descriptions – EtherCAT Setup

Mode: Regeneration

Parameter		Range	Default	Type					
13.001	Module ID	0 to 65535		RO	Num	ND	NC	PT	
13.002	Software Version	0 to 99999999		RO	Num	ND	NC	PT	
13.003	Hardware version	0.00 to 655.35		RO	Num	ND	NC	PT	
13.004	Serial Number LS	00000000 to 99999999		RO	Num	ND	NC	PT	
13.005	Serial Number MS	0 to 99999999		RO	Num	ND	NC	PT	
13.006	Status	Bootldr - Update (-2), Bootldr - Idle (-1), Initialising (0), OK (1), Config (2), Error (3)		RO	Txt	ND	NC	PT	
13.007	Reset	Off (0) or On (1)	Off (0)	RW	Bit		NC		
13.008	Default	Off (0) or On (1)	Off (0)	RW	Bit		NC		
13.031	Slot indicator	1 to 8		RO	Num	ND	NC	PT	
13.032	Slot menu number	0 to 255		RO	Num	ND	NC	PT	
13.033	Disable drive control	Off (0) or On (1)	Off (0)	RW	Bit				US
13.034	Allow EEPROM Upgrade	Off (0) or On (1)	Off (0)	RW	Bit				
13.035	Configured station alias	0 to 65535	0	RW	Num		NC	PT	US
13.036	Consistency trigger for synchronous outputs	Off (0) or On (1)	Off (0)	RW	Bit				US
13.037	Consistency trigger parameter for synchronous outputs	0 to 999999	0	RW	Num	DE			US
13.038	Consistency trigger for synchronous inputs	Off (0) or On (1)	Off (0)	RW	Bit				US
13.039	Consistency trigger parameter for synchronous inputs	0 to 999999	0	RW	Num	DE			US
13.040	Consistency trigger for non-synchronous outputs	Off (0) or On (1)	Off (0)	RW	Bit				US
13.041	Consistency trigger parameter for non-synchronous outputs	0 to 999999	0	RW	Num	DE			US
13.042	Consistency trigger for non-synchronous inputs	Off (0) or On (1)	Off (0)	RW	Bit				US
13.043	Consistency trigger parameter for non-synchronous inputs	0 to 999999	0	RW	Num	DE			US
13.045	Homing Position Save	Off (0) or On (1)	Off (0)	RW	Bit			PT	US
13.046	Homing Position Parameter	51 to 54	51	RW	Num			PT	US

RW	Read / Write	RO	Read-only	Bit	Bit parameter	Txt	Text string	Date	Date parameter	Time	Time parameter
Chr	Character parameter	Bin	Binary parameter	IP	IP address	Mac	MAC address	Ver	Version number	SMP	Slot, menu, parameter
Num	Number parameter	DE	Destination	ND	No default value	RA	Rating dependent	NC	Non-copyable	PT	Protected
FI	Filtered	US	User save	PS	Power-down save						

Menu 17 – EtherCAT Setup

Mode: Regeneration

Menu 17 is a duplication of slot 3 menu 0. For a description of a particular parameter, click on the relevant slot parameter in the table below.

Drive Parameter	Slot Parameter
17.001 <i>Module ID</i>	3.00.001 <i>Module ID</i>
17.002 <i>Software Version</i>	3.00.002 <i>Software Version</i>
17.003 <i>Hardware version</i>	3.00.003 <i>Hardware version</i>
17.004 <i>Serial Number LS</i>	3.00.004 <i>Serial Number LS</i>
17.005 <i>Serial Number MS</i>	3.00.005 <i>Serial Number MS</i>
17.006 <i>Status</i>	3.00.006 <i>Status</i>
17.007 <i>Reset</i>	3.00.007 <i>Reset</i>
17.008 <i>Default</i>	3.00.008 <i>Default</i>
17.031 <i>Slot indicator</i>	3.00.031 <i>Slot indicator</i>
17.032 <i>Slot menu number</i>	3.00.032 <i>Slot menu number</i>
17.033 <i>Disable drive control</i>	3.00.033 <i>Disable drive control</i>
17.034 <i>Allow EEPROM Upgrade</i>	3.00.034 <i>Allow EEPROM Upgrade</i>
17.035 <i>Configured station alias</i>	3.00.035 <i>Configured station alias</i>
17.036 <i>Consistency trigger for synchronous outputs</i>	3.00.036 <i>Consistency trigger for synchronous outputs</i>
17.037 <i>Consistency trigger parameter for synchronous outputs</i>	3.00.037 <i>Consistency trigger parameter for synchronous outputs</i>
17.038 <i>Consistency trigger for synchronous inputs</i>	3.00.038 <i>Consistency trigger for synchronous inputs</i>
17.039 <i>Consistency trigger parameter for synchronous inputs</i>	3.00.039 <i>Consistency trigger parameter for synchronous inputs</i>
17.040 <i>Consistency trigger for non-synchronous outputs</i>	3.00.040 <i>Consistency trigger for non-synchronous outputs</i>
17.041 <i>Consistency trigger parameter for non-synchronous outputs</i>	3.00.041 <i>Consistency trigger parameter for non-synchronous outputs</i>
17.042 <i>Consistency trigger for non-synchronous inputs</i>	3.00.042 <i>Consistency trigger for non-synchronous inputs</i>
17.043 <i>Consistency trigger parameter for non-synchronous inputs</i>	3.00.043 <i>Consistency trigger parameter for non-synchronous inputs</i>
17.045 <i>Homing Position Save</i>	3.00.045 <i>Homing Position Save</i>
17.046 <i>Homing Position Parameter</i>	3.00.046 <i>Homing Position Parameter</i>

Menu 18 Single Line Descriptions – Application Menu 1

Mode: Regeneration

Parameter	Range	Default	Type						
			RW	Num	ND	NC	PS		
18.001	Application Menu 1 Power-down Save Integer	-32768 to 32767	0	RW	Num				PS
18.002	Application Menu 1 Read-only Integer 2	-32768 to 32767		RO	Num	ND	NC		
18.003	Application Menu 1 Read-only Integer 3	-32768 to 32767		RO	Num	ND	NC		
18.004	Application Menu 1 Read-only Integer 4	-32768 to 32767		RO	Num	ND	NC		
18.005	Application Menu 1 Read-only Integer 5	-32768 to 32767		RO	Num	ND	NC		
18.006	Application Menu 1 Read-only Integer 6	-32768 to 32767		RO	Num	ND	NC		
18.007	Application Menu 1 Read-only Integer 7	-32768 to 32767		RO	Num	ND	NC		
18.008	Application Menu 1 Read-only Integer 8	-32768 to 32767		RO	Num	ND	NC		
18.009	Application Menu 1 Read-only Integer 9	-32768 to 32767		RO	Num	ND	NC		
18.010	Application Menu 1 Read-only Integer 10	-32768 to 32767		RO	Num	ND	NC		
18.011	Application Menu 1 Read-write Integer 11	-32768 to 32767	0	RW	Num				US
18.012	Application Menu 1 Read-write Integer 12	-32768 to 32767	0	RW	Num				US
18.013	Application Menu 1 Read-write Integer 13	-32768 to 32767	0	RW	Num				US
18.014	Application Menu 1 Read-write Integer 14	-32768 to 32767	0	RW	Num				US
18.015	Application Menu 1 Read-write Integer 15	-32768 to 32767	0	RW	Num				US
18.016	Application Menu 1 Read-write Integer 16	-32768 to 32767	0	RW	Num				US
18.017	Application Menu 1 Read-write Integer 17	-32768 to 32767	0	RW	Num				US
18.018	Application Menu 1 Read-write Integer 18	-32768 to 32767	0	RW	Num				US
18.019	Application Menu 1 Read-write Integer 19	-32768 to 32767	0	RW	Num				US
18.020	Application Menu 1 Read-write Integer 20	-32768 to 32767	0	RW	Num				US
18.021	Application Menu 1 Read-write Integer 21	-32768 to 32767	0	RW	Num				US
18.022	Application Menu 1 Read-write Integer 22	-32768 to 32767	0	RW	Num				US
18.023	Application Menu 1 Read-write Integer 23	-32768 to 32767	0	RW	Num				US
18.024	Application Menu 1 Read-write Integer 24	-32768 to 32767	0	RW	Num				US
18.025	Application Menu 1 Read-write Integer 25	-32768 to 32767	0	RW	Num				US
18.026	Application Menu 1 Read-write Integer 26	-32768 to 32767	0	RW	Num				US
18.027	Application Menu 1 Read-write Integer 27	-32768 to 32767	0	RW	Num				US
18.028	Application Menu 1 Read-write Integer 28	-32768 to 32767	0	RW	Num				US
18.029	Application Menu 1 Read-write Integer 29	-32768 to 32767	0	RW	Num				US
18.030	Application Menu 1 Read-write Integer 30	-32768 to 32767	0	RW	Num				US
18.031	Application Menu 1 Read-write bit 31	Off (0) or On (1)	Off (0)	RW	Bit				US
18.032	Application Menu 1 Read-write bit 32	Off (0) or On (1)	Off (0)	RW	Bit				US
18.033	Application Menu 1 Read-write bit 33	Off (0) or On (1)	Off (0)	RW	Bit				US
18.034	Application Menu 1 Read-write bit 34	Off (0) or On (1)	Off (0)	RW	Bit				US
18.035	Application Menu 1 Read-write bit 35	Off (0) or On (1)	Off (0)	RW	Bit				US
18.036	Application Menu 1 Read-write bit 36	Off (0) or On (1)	Off (0)	RW	Bit				US
18.037	Application Menu 1 Read-write bit 37	Off (0) or On (1)	Off (0)	RW	Bit				US
18.038	Application Menu 1 Read-write bit 38	Off (0) or On (1)	Off (0)	RW	Bit				US
18.039	Application Menu 1 Read-write bit 39	Off (0) or On (1)	Off (0)	RW	Bit				US
18.040	Application Menu 1 Read-write bit 40	Off (0) or On (1)	Off (0)	RW	Bit				US
18.041	Application Menu 1 Read-write bit 41	Off (0) or On (1)	Off (0)	RW	Bit				US
18.042	Application Menu 1 Read-write bit 42	Off (0) or On (1)	Off (0)	RW	Bit				US
18.043	Application Menu 1 Read-write bit 43	Off (0) or On (1)	Off (0)	RW	Bit				US
18.044	Application Menu 1 Read-write bit 44	Off (0) or On (1)	Off (0)	RW	Bit				US
18.045	Application Menu 1 Read-write bit 45	Off (0) or On (1)	Off (0)	RW	Bit				US
18.046	Application Menu 1 Read-write bit 46	Off (0) or On (1)	Off (0)	RW	Bit				US
18.047	Application Menu 1 Read-write bit 47	Off (0) or On (1)	Off (0)	RW	Bit				US
18.048	Application Menu 1 Read-write bit 48	Off (0) or On (1)	Off (0)	RW	Bit				US
18.049	Application Menu 1 Read-write bit 49	Off (0) or On (1)	Off (0)	RW	Bit				US
18.050	Application Menu 1 Read-write bit 50	Off (0) or On (1)	Off (0)	RW	Bit				US
18.051	Application Menu 1 Power-down Save Long Integer 51	-2147483648 to 2147483647	0	RW	Num				PS
18.052	Application Menu 1 Power-down Save Long Integer 52	-2147483648 to 2147483647	0	RW	Num				PS
18.053	Application Menu 1 Power-down Save Long Integer 53	-2147483648 to 2147483647	0	RW	Num				PS
18.054	Application Menu 1 Power-down Save Long Integer 54	-2147483648 to 2147483647	0	RW	Num				PS

RW	Read / Write	RO	Read-only	Bit	Bit parameter	Txt	Text string	Date	Date parameter	Time	Time parameter
Chr	Character parameter	Bin	Binary parameter	IP	IP address	Mac	MAC address	Ver	Version number	SMP	Slot, menu, parameter
Num	Number parameter	DE	Destination	ND	No default value	RA	Rating dependent	NC	Non-copyable	PT	Protected
Fl	Filtered	US	User save	PS	Power-down save						

Menu 18 – Application Menu 1

Mode: Regeneration

Menus 18-20 are general application menus that can be used by one of the option modules fitted to the drive. These menus are customisable and the following RAM is provided to be shared between all 3 menus. This is based on increasing the RAM provided for Unidrive SP by approximately 20%.

	1	8	16	32
Volatile	0	32	64	32
User save	64	32	48	12
Power-down save	0	0	2	8

If no option modules provide customisation tables for these menus then the drive provides the customisation tables to give the following parameters.

Parameter	18.001 Application Menu 1 Power-down Save Integer		
Short description	General power-down save integer application parameter		
Mode	Regeneration		
Minimum	-32768	Maximum	32767
Default	0	Units	
Type	16 Bit Power Down Save	Update Rate	N/A
Display Format	Standard	Decimal Places	0
Coding	RW		

Parameter	18.002 Application Menu 1 Read-only Integer 2		
Short description	General read-only integer application parameter		
Mode	Regeneration		
Minimum	-32768	Maximum	32767
Default		Units	
Type	16 Bit Volatile	Update Rate	N/A
Display Format	Standard	Decimal Places	0
Coding	RO, PR, ND, NC		

Parameter	18.003 Application Menu 1 Read-only Integer 3		
Short description	General read-only integer application parameter		
Mode	Regeneration		
Minimum	-32768	Maximum	32767
Default		Units	
Type	16 Bit Volatile	Update Rate	N/A
Display Format	Standard	Decimal Places	0
Coding	RO, PR, ND, NC		

Parameter	18.004 Application Menu 1 Read-only Integer 4		
Short description	General read-only integer application parameter		
Mode	Regeneration		
Minimum	-32768	Maximum	32767
Default		Units	
Type	16 Bit Volatile	Update Rate	N/A
Display Format	Standard	Decimal Places	0
Coding	RO, PR, ND, NC		

Parameter	18.005 Application Menu 1 Read-only Integer 5		
Short description	General read-only integer application parameter		
Mode	Regeneration		
Minimum	-32768	Maximum	32767
Default		Units	
Type	16 Bit Volatile	Update Rate	N/A
Display Format	Standard	Decimal Places	0
Coding	RO, PR, ND, NC		

Parameter	18.006 Application Menu 1 Read-only Integer 6		
Short description	General read-only integer application parameter		
Mode	Regeneration		
Minimum	-32768	Maximum	32767
Default		Units	
Type	16 Bit Volatile	Update Rate	N/A
Display Format	Standard	Decimal Places	0
Coding	RO, PR, ND, NC		

Parameter	18.007 Application Menu 1 Read-only Integer 7		
Short description	General read-only integer application parameter		
Mode	Regeneration		
Minimum	-32768	Maximum	32767
Default		Units	
Type	16 Bit Volatile	Update Rate	N/A
Display Format	Standard	Decimal Places	0
Coding	RO, PR, ND, NC		

Parameter	18.008 Application Menu 1 Read-only Integer 8		
Short description	General read-only integer application parameter		
Mode	Regeneration		
Minimum	-32768	Maximum	32767
Default		Units	
Type	16 Bit Volatile	Update Rate	N/A
Display Format	Standard	Decimal Places	0
Coding	RO, PR, ND, NC		

Parameter	18.009 Application Menu 1 Read-only Integer 9		
Short description	General read-only integer application parameter		
Mode	Regeneration		
Minimum	-32768	Maximum	32767
Default		Units	
Type	16 Bit Volatile	Update Rate	N/A
Display Format	Standard	Decimal Places	0
Coding	RO, PR, ND, NC		

Parameter	18.010 Application Menu 1 Read-only Integer 10		
Short description	General read-only integer application parameter		
Mode	Regeneration		
Minimum	-32768	Maximum	32767
Default		Units	
Type	16 Bit Volatile	Update Rate	N/A
Display Format	Standard	Decimal Places	0
Coding	RO, PR, ND, NC		

Parameter	18.011 Application Menu 1 Read-write Integer 11		
Short description	General read-write integer application parameter		
Mode	Regeneration		
Minimum	-32768	Maximum	32767
Default	0	Units	
Type	16 Bit User Save	Update Rate	N/A
Display Format	Standard	Decimal Places	0
Coding	RW		

Parameter	18.012 Application Menu 1 Read-write Integer 12		
Short description	General read-write integer application parameter		
Mode	Regeneration		
Minimum	-32768	Maximum	32767
Default	0	Units	
Type	16 Bit User Save	Update Rate	N/A
Display Format	Standard	Decimal Places	0
Coding	RW		

Parameter	18.013 Application Menu 1 Read-write Integer 13		
Short description	General read-write integer application parameter		
Mode	Regeneration		
Minimum	-32768	Maximum	32767
Default	0	Units	
Type	16 Bit User Save	Update Rate	N/A
Display Format	Standard	Decimal Places	0
Coding	RW		

Parameter	18.014 Application Menu 1 Read-write Integer 14		
Short description	General read-write integer application parameter		
Mode	Regeneration		
Minimum	-32768	Maximum	32767
Default	0	Units	
Type	16 Bit User Save	Update Rate	N/A
Display Format	Standard	Decimal Places	0
Coding	RW		

Parameter	18.015 Application Menu 1 Read-write Integer 15		
Short description	General read-write integer application parameter		
Mode	Regeneration		
Minimum	-32768	Maximum	32767
Default	0	Units	
Type	16 Bit User Save	Update Rate	N/A
Display Format	Standard	Decimal Places	0
Coding	RW		

Parameter	18.016 Application Menu 1 Read-write Integer 16		
Short description	General read-write integer application parameter		
Mode	Regeneration		
Minimum	-32768	Maximum	32767
Default	0	Units	
Type	16 Bit User Save	Update Rate	N/A
Display Format	Standard	Decimal Places	0
Coding	RW		

Parameter	18.017 Application Menu 1 Read-write Integer 17		
Short description	General read-write integer application parameter		
Mode	Regeneration		
Minimum	-32768	Maximum	32767
Default	0	Units	
Type	16 Bit User Save	Update Rate	N/A
Display Format	Standard	Decimal Places	0
Coding	RW		

Parameter	18.018 Application Menu 1 Read-write Integer 18		
Short description	General read-write integer application parameter		
Mode	Regeneration		
Minimum	-32768	Maximum	32767
Default	0	Units	
Type	16 Bit User Save	Update Rate	N/A
Display Format	Standard	Decimal Places	0
Coding	RW		

Parameter	18.019 Application Menu 1 Read-write Integer 19		
Short description	General read-write integer application parameter		
Mode	Regeneration		
Minimum	-32768	Maximum	32767
Default	0	Units	
Type	16 Bit User Save	Update Rate	N/A
Display Format	Standard	Decimal Places	0
Coding	RW		

Parameter	18.020 Application Menu 1 Read-write Integer 20		
Short description	General read-write integer application parameter		
Mode	Regeneration		
Minimum	-32768	Maximum	32767
Default	0	Units	
Type	16 Bit User Save	Update Rate	N/A
Display Format	Standard	Decimal Places	0
Coding	RW		

Parameter	18.021 Application Menu 1 Read-write Integer 21		
Short description	General read-write integer application parameter		
Mode	Regeneration		
Minimum	-32768	Maximum	32767
Default	0	Units	
Type	16 Bit User Save	Update Rate	N/A
Display Format	Standard	Decimal Places	0
Coding	RW		

Parameter	18.022 Application Menu 1 Read-write Integer 22		
Short description	General read-write integer application parameter		
Mode	Regeneration		
Minimum	-32768	Maximum	32767
Default	0	Units	
Type	16 Bit User Save	Update Rate	N/A
Display Format	Standard	Decimal Places	0
Coding	RW		

Parameter	18.023 Application Menu 1 Read-write Integer 23		
Short description	General read-write integer application parameter		
Mode	Regeneration		
Minimum	-32768	Maximum	32767
Default	0	Units	
Type	16 Bit User Save	Update Rate	N/A
Display Format	Standard	Decimal Places	0
Coding	RW		

Parameter	18.024 Application Menu 1 Read-write Integer 24		
Short description	General read-write integer application parameter		
Mode	Regeneration		
Minimum	-32768	Maximum	32767
Default	0	Units	
Type	16 Bit User Save	Update Rate	N/A
Display Format	Standard	Decimal Places	0
Coding	RW		

Parameter	18.025 Application Menu 1 Read-write Integer 25		
Short description	General read-write integer application parameter		
Mode	Regeneration		
Minimum	-32768	Maximum	32767
Default	0	Units	
Type	16 Bit User Save	Update Rate	N/A
Display Format	Standard	Decimal Places	0
Coding	RW		

Parameter	18.026 Application Menu 1 Read-write Integer 26		
Short description	General read-write integer application parameter		
Mode	Regeneration		
Minimum	-32768	Maximum	32767
Default	0	Units	
Type	16 Bit User Save	Update Rate	N/A
Display Format	Standard	Decimal Places	0
Coding	RW		

Parameter	18.027 Application Menu 1 Read-write Integer 27		
Short description	General read-write integer application parameter		
Mode	Regeneration		
Minimum	-32768	Maximum	32767
Default	0	Units	
Type	16 Bit User Save	Update Rate	N/A
Display Format	Standard	Decimal Places	0
Coding	RW		

Parameter	18.028 Application Menu 1 Read-write Integer 28		
Short description	General read-write integer application parameter		
Mode	Regeneration		
Minimum	-32768	Maximum	32767
Default	0	Units	
Type	16 Bit User Save	Update Rate	N/A
Display Format	Standard	Decimal Places	0
Coding	RW		

Parameter	18.029 Application Menu 1 Read-write Integer 29		
Short description	General read-write integer application parameter		
Mode	Regeneration		
Minimum	-32768	Maximum	32767
Default	0	Units	
Type	16 Bit User Save	Update Rate	N/A
Display Format	Standard	Decimal Places	0
Coding	RW		

Parameter	18.030 Application Menu 1 Read-write Integer 30		
Short description	General read-write integer application parameter		
Mode	Regeneration		
Minimum	-32768	Maximum	32767
Default	0	Units	
Type	16 Bit User Save	Update Rate	N/A
Display Format	Standard	Decimal Places	0
Coding	RW		

Parameter	18.031 Application Menu 1 Read-write bit 31		
Short description	General read-write bit application parameter		
Mode	Regeneration		
Minimum	0	Maximum	1
Default	0	Units	
Type	1 Bit User Save	Update Rate	N/A
Display Format	Standard	Decimal Places	0
Coding	RW		

Parameter	18.032 Application Menu 1 Read-write bit 32		
Short description	General read-write bit application parameter		
Mode	Regeneration		
Minimum	0	Maximum	1
Default	0	Units	
Type	1 Bit User Save	Update Rate	N/A
Display Format	Standard	Decimal Places	0
Coding	RW		

Parameter	18.033 Application Menu 1 Read-write bit 33		
Short description	General read-write bit application parameter		
Mode	Regeneration		
Minimum	0	Maximum	1
Default	0	Units	
Type	1 Bit User Save	Update Rate	N/A
Display Format	Standard	Decimal Places	0
Coding	RW		

Parameter	18.034 Application Menu 1 Read-write bit 34		
Short description	General read-write bit application parameter		
Mode	Regeneration		
Minimum	0	Maximum	1
Default	0	Units	
Type	1 Bit User Save	Update Rate	N/A
Display Format	Standard	Decimal Places	0
Coding	RW		

Parameter	18.035 Application Menu 1 Read-write bit 35		
Short description	General read-write bit application parameter		
Mode	Regeneration		
Minimum	0	Maximum	1
Default	0	Units	
Type	1 Bit User Save	Update Rate	N/A
Display Format	Standard	Decimal Places	0
Coding	RW		

Parameter	18.036 Application Menu 1 Read-write bit 36		
Short description	General read-write bit application parameter		
Mode	Regeneration		
Minimum	0	Maximum	1
Default	0	Units	
Type	1 Bit User Save	Update Rate	N/A
Display Format	Standard	Decimal Places	0
Coding	RW		

Parameter	18.037 Application Menu 1 Read-write bit 37		
Short description	General read-write bit application parameter		
Mode	Regeneration		
Minimum	0	Maximum	1
Default	0	Units	
Type	1 Bit User Save	Update Rate	N/A
Display Format	Standard	Decimal Places	0
Coding	RW		

Parameter	18.038 Application Menu 1 Read-write bit 38		
Short description	General read-write bit application parameter		
Mode	Regeneration		
Minimum	0	Maximum	1
Default	0	Units	
Type	1 Bit User Save	Update Rate	N/A
Display Format	Standard	Decimal Places	0
Coding	RW		

Parameter	18.039 Application Menu 1 Read-write bit 39		
Short description	General read-write bit application parameter		
Mode	Regeneration		
Minimum	0	Maximum	1
Default	0	Units	
Type	1 Bit User Save	Update Rate	N/A
Display Format	Standard	Decimal Places	0
Coding	RW		

Parameter	18.040 Application Menu 1 Read-write bit 40		
Short description	General read-write bit application parameter		
Mode	Regeneration		
Minimum	0	Maximum	1
Default	0	Units	
Type	1 Bit User Save	Update Rate	N/A
Display Format	Standard	Decimal Places	0
Coding	RW		

Parameter	18.041 Application Menu 1 Read-write bit 41		
Short description	General read-write bit application parameter		
Mode	Regeneration		
Minimum	0	Maximum	1
Default	0	Units	
Type	1 Bit User Save	Update Rate	N/A
Display Format	Standard	Decimal Places	0
Coding	RW		

Parameter	18.042 Application Menu 1 Read-write bit 42		
Short description	General read-write bit application parameter		
Mode	Regeneration		
Minimum	0	Maximum	1
Default	0	Units	
Type	1 Bit User Save	Update Rate	N/A
Display Format	Standard	Decimal Places	0
Coding	RW		

Parameter	18.043 Application Menu 1 Read-write bit 43		
Short description	General read-write bit application parameter		
Mode	Regeneration		
Minimum	0	Maximum	1
Default	0	Units	
Type	1 Bit User Save	Update Rate	N/A
Display Format	Standard	Decimal Places	0
Coding	RW		

Parameter	18.044 Application Menu 1 Read-write bit 44		
Short description	General read-write bit application parameter		
Mode	Regeneration		
Minimum	0	Maximum	1
Default	0	Units	
Type	1 Bit User Save	Update Rate	N/A
Display Format	Standard	Decimal Places	0
Coding	RW		

Parameter	18.045 Application Menu 1 Read-write bit 45		
Short description	General read-write bit application parameter		
Mode	Regeneration		
Minimum	0	Maximum	1
Default	0	Units	
Type	1 Bit User Save	Update Rate	N/A
Display Format	Standard	Decimal Places	0
Coding	RW		

Parameter	18.046 Application Menu 1 Read-write bit 46		
Short description	General read-write bit application parameter		
Mode	Regeneration		
Minimum	0	Maximum	1
Default	0	Units	
Type	1 Bit User Save	Update Rate	N/A
Display Format	Standard	Decimal Places	0
Coding	RW		

Parameter	18.047 Application Menu 1 Read-write bit 47		
Short description	General read-write bit application parameter		
Mode	Regeneration		
Minimum	0	Maximum	1
Default	0	Units	
Type	1 Bit User Save	Update Rate	N/A
Display Format	Standard	Decimal Places	0
Coding	RW		

Parameter	18.048 Application Menu 1 Read-write bit 48		
Short description	General read-write bit application parameter		
Mode	Regeneration		
Minimum	0	Maximum	1
Default	0	Units	
Type	1 Bit User Save	Update Rate	N/A
Display Format	Standard	Decimal Places	0
Coding	RW		

Parameter	18.049 Application Menu 1 Read-write bit 49		
Short description	General read-write bit application parameter		
Mode	Regeneration		
Minimum	0	Maximum	1
Default	0	Units	
Type	1 Bit User Save	Update Rate	N/A
Display Format	Standard	Decimal Places	0
Coding	RW		

Parameter	18.050 Application Menu 1 Read-write bit 50		
Short description	General read-write bit application parameter		
Mode	Regeneration		
Minimum	0	Maximum	1
Default	0	Units	
Type	1 Bit User Save	Update Rate	N/A
Display Format	Standard	Decimal Places	0
Coding	RW		

Parameter	18.051 Application Menu 1 Power-down Save Long Integer 51		
Short description	General power-down save long integer application parameter		
Mode	Regeneration		
Minimum	-2147483648	Maximum	2147483647
Default	0	Units	
Type	32 Bit Power Down Save	Update Rate	N/A
Display Format	Standard	Decimal Places	0
Coding	RW		

Parameter	18.052 Application Menu 1 Power-down Save Long Integer 52		
Short description	General power-down save long integer application parameter		
Mode	Regeneration		
Minimum	-2147483648	Maximum	2147483647
Default	0	Units	
Type	32 Bit Power Down Save	Update Rate	N/A
Display Format	Standard	Decimal Places	0
Coding	RW		

Parameter	18.053 Application Menu 1 Power-down Save Long Integer 53		
Short description	General power-down save long integer application parameter		
Mode	Regeneration		
Minimum	-2147483648	Maximum	2147483647
Default	0	Units	
Type	32 Bit Power Down Save	Update Rate	N/A
Display Format	Standard	Decimal Places	0
Coding	RW		

Parameter	18.054 Application Menu 1 Power-down Save Long Integer 54		
Short description	General power-down save long integer application parameter		
Mode	Regeneration		
Minimum	-2147483648	Maximum	2147483647
Default	0	Units	
Type	32 Bit Power Down Save	Update Rate	N/A
Display Format	Standard	Decimal Places	0
Coding	RW		

Menu 19 Single Line Descriptions – Application Menu 2

Mode: Regeneration

ID	Parameter	Range	Default	Type				
				RW	Num	ND	NC	PS
19.001	Application Menu 2 Power-down Save Integer	-32768 to 32767	0	RW	Num			PS
19.002	Application Menu 2 Read-only Integer 2	-32768 to 32767		RO	Num	ND	NC	
19.003	Application Menu 2 Read-only Integer 3	-32768 to 32767		RO	Num	ND	NC	
19.004	Application Menu 2 Read-only Integer 4	-32768 to 32767		RO	Num	ND	NC	
19.005	Application Menu 2 Read-only Integer 5	-32768 to 32767		RO	Num	ND	NC	
19.006	Application Menu 2 Read-only Integer 6	-32768 to 32767		RO	Num	ND	NC	
19.007	Application Menu 2 Read-only Integer 7	-32768 to 32767		RO	Num	ND	NC	
19.008	Application Menu 2 Read-only Integer 8	-32768 to 32767		RO	Num	ND	NC	
19.009	Application Menu 2 Read-only Integer 9	-32768 to 32767		RO	Num	ND	NC	
19.010	Application Menu 2 Read-only Integer 10	-32768 to 32767		RO	Num	ND	NC	
19.011	Application Menu 2 Read-write Integer 11	-32768 to 32767	0	RW	Num			US
19.012	Application Menu 2 Read-write Integer 12	-32768 to 32767	0	RW	Num			US
19.013	Application Menu 2 Read-write Integer 13	-32768 to 32767	0	RW	Num			US
19.014	Application Menu 2 Read-write Integer 14	-32768 to 32767	0	RW	Num			US
19.015	Application Menu 2 Read-write Integer 15	-32768 to 32767	0	RW	Num			US
19.016	Application Menu 2 Read-write Integer 16	-32768 to 32767	0	RW	Num			US
19.017	Application Menu 2 Read-write Integer 17	-32768 to 32767	0	RW	Num			US
19.018	Application Menu 2 Read-write Integer 18	-32768 to 32767	0	RW	Num			US
19.019	Application Menu 2 Read-write Integer 19	-32768 to 32767	0	RW	Num			US
19.020	Application Menu 2 Read-write Integer 20	-32768 to 32767	0	RW	Num			US
19.021	Application Menu 2 Read-write Integer 21	-32768 to 32767	0	RW	Num			US
19.022	Application Menu 2 Read-write Integer 22	-32768 to 32767	0	RW	Num			US
19.023	Application Menu 2 Read-write Integer 23	-32768 to 32767	0	RW	Num			US
19.024	Application Menu 2 Read-write Integer 24	-32768 to 32767	0	RW	Num			US
19.025	Application Menu 2 Read-write Integer 25	-32768 to 32767	0	RW	Num			US
19.026	Application Menu 2 Read-write Integer 26	-32768 to 32767	0	RW	Num			US
19.027	Application Menu 2 Read-write Integer 27	-32768 to 32767	0	RW	Num			US
19.028	Application Menu 2 Read-write Integer 28	-32768 to 32767	0	RW	Num			US
19.029	Application Menu 2 Read-write Integer 29	-32768 to 32767	0	RW	Num			US
19.030	Application Menu 2 Read-write Integer 30	-32768 to 32767	0	RW	Num			US
19.031	Application Menu 2 Read-write bit 31	Off (0) or On (1)	Off (0)	RW	Bit			US
19.032	Application Menu 2 Read-write bit 32	Off (0) or On (1)	Off (0)	RW	Bit			US
19.033	Application Menu 2 Read-write bit 33	Off (0) or On (1)	Off (0)	RW	Bit			US
19.034	Application Menu 2 Read-write bit 34	Off (0) or On (1)	Off (0)	RW	Bit			US
19.035	Application Menu 2 Read-write bit 35	Off (0) or On (1)	Off (0)	RW	Bit			US
19.036	Application Menu 2 Read-write bit 36	Off (0) or On (1)	Off (0)	RW	Bit			US
19.037	Application Menu 2 Read-write bit 37	Off (0) or On (1)	Off (0)	RW	Bit			US
19.038	Application Menu 2 Read-write bit 38	Off (0) or On (1)	Off (0)	RW	Bit			US
19.039	Application Menu 2 Read-write bit 39	Off (0) or On (1)	Off (0)	RW	Bit			US
19.040	Application Menu 2 Read-write bit 40	Off (0) or On (1)	Off (0)	RW	Bit			US
19.041	Application Menu 2 Read-write bit 41	Off (0) or On (1)	Off (0)	RW	Bit			US
19.042	Application Menu 2 Read-write bit 42	Off (0) or On (1)	Off (0)	RW	Bit			US
19.043	Application Menu 2 Read-write bit 43	Off (0) or On (1)	Off (0)	RW	Bit			US
19.044	Application Menu 2 Read-write bit 44	Off (0) or On (1)	Off (0)	RW	Bit			US
19.045	Application Menu 2 Read-write bit 45	Off (0) or On (1)	Off (0)	RW	Bit			US
19.046	Application Menu 2 Read-write bit 46	Off (0) or On (1)	Off (0)	RW	Bit			US
19.047	Application Menu 2 Read-write bit 47	Off (0) or On (1)	Off (0)	RW	Bit			US
19.048	Application Menu 2 Read-write bit 48	Off (0) or On (1)	Off (0)	RW	Bit			US
19.049	Application Menu 2 Read-write bit 49	Off (0) or On (1)	Off (0)	RW	Bit			US
19.050	Application Menu 2 Read-write bit 50	Off (0) or On (1)	Off (0)	RW	Bit			US
19.051	Application Menu 2 Power-down Save Long Integer 51	-2147483648 to 2147483647	0	RW	Num			PS
19.052	Application Menu 2 Power-down Save Long Integer 52	-2147483648 to 2147483647	0	RW	Num			PS
19.053	Application Menu 2 Power-down Save Long Integer 53	-2147483648 to 2147483647	0	RW	Num			PS
19.054	Application Menu 2 Power-down Save Long Integer 54	-2147483648 to 2147483647	0	RW	Num			PS

RW	Read / Write	RO	Read-only	Bit	Bit parameter	Txt	Text string	Date	Date parameter	Time	Time parameter
Chr	Character parameter	Bin	Binary parameter	IP	IP address	Mac	MAC address	Ver	Version number	SMP	Slot, menu, parameter
Num	Number parameter	DE	Destination	ND	No default value	RA	Rating dependent	NC	Non-copyable	PT	Protected
FI	Filtered	US	User save	PS	Power-down save						

Menu 19 – Application Menu 2

Mode: Regeneration

See the introduction to menu 18.

Parameter	19.001 Application Menu 2 Power-down Save Integer		
Short description	General power-down save integer application parameter		
Mode	Regeneration		
Minimum	-32768	Maximum	32767
Default	0	Units	
Type	16 Bit Power Down Save	Update Rate	N/A
Display Format	Standard	Decimal Places	0
Coding	RW		

Parameter	19.002 Application Menu 2 Read-only Integer 2		
Short description	General read-only integer application parameter		
Mode	Regeneration		
Minimum	-32768	Maximum	32767
Default		Units	
Type	16 Bit Volatile	Update Rate	N/A
Display Format	Standard	Decimal Places	0
Coding	RO, PR, ND, NC		

Parameter	19.003 Application Menu 2 Read-only Integer 3		
Short description	General read-only integer application parameter		
Mode	Regeneration		
Minimum	-32768	Maximum	32767
Default		Units	
Type	16 Bit Volatile	Update Rate	N/A
Display Format	Standard	Decimal Places	0
Coding	RO, PR, ND, NC		

Parameter	19.004 Application Menu 2 Read-only Integer 4		
Short description	General read-only integer application parameter		
Mode	Regeneration		
Minimum	-32768	Maximum	32767
Default		Units	
Type	16 Bit Volatile	Update Rate	N/A
Display Format	Standard	Decimal Places	0
Coding	RO, PR, ND, NC		

Parameter	19.005 Application Menu 2 Read-only Integer 5		
Short description	General read-only integer application parameter		
Mode	Regeneration		
Minimum	-32768	Maximum	32767
Default		Units	
Type	16 Bit Volatile	Update Rate	N/A
Display Format	Standard	Decimal Places	0
Coding	RO, PR, ND, NC		

Parameter	19.006 Application Menu 2 Read-only Integer 6		
Short description	General read-only integer application parameter		
Mode	Regeneration		
Minimum	-32768	Maximum	32767
Default		Units	
Type	16 Bit Volatile	Update Rate	N/A
Display Format	Standard	Decimal Places	0
Coding	RO, PR, ND, NC		

Parameter	19.007 Application Menu 2 Read-only Integer 7		
Short description	General read-only integer application parameter		
Mode	Regeneration		
Minimum	-32768	Maximum	32767
Default		Units	
Type	16 Bit Volatile	Update Rate	N/A
Display Format	Standard	Decimal Places	0
Coding	RO, PR, ND, NC		

Parameter	19.008 Application Menu 2 Read-only Integer 8		
Short description	General read-only integer application parameter		
Mode	Regeneration		
Minimum	-32768	Maximum	32767
Default		Units	
Type	16 Bit Volatile	Update Rate	N/A
Display Format	Standard	Decimal Places	0
Coding	RO, PR, ND, NC		

Parameter	19.009 Application Menu 2 Read-only Integer 9		
Short description	General read-only integer application parameter		
Mode	Regeneration		
Minimum	-32768	Maximum	32767
Default		Units	
Type	16 Bit Volatile	Update Rate	N/A
Display Format	Standard	Decimal Places	0
Coding	RO, PR, ND, NC		

Parameter	19.010 Application Menu 2 Read-only Integer 10		
Short description	General read-only integer application parameter		
Mode	Regeneration		
Minimum	-32768	Maximum	32767
Default		Units	
Type	16 Bit Volatile	Update Rate	N/A
Display Format	Standard	Decimal Places	0
Coding	RO, PR, ND, NC		

Parameter	19.011 Application Menu 2 Read-write Integer 11		
Short description	General read-write integer application parameter		
Mode	Regeneration		
Minimum	-32768	Maximum	32767
Default	0	Units	
Type	16 Bit User Save	Update Rate	N/A
Display Format	Standard	Decimal Places	0
Coding	RW		

Parameter	19.012 Application Menu 2 Read-write Integer 12		
Short description	General read-write integer application parameter		
Mode	Regeneration		
Minimum	-32768	Maximum	32767
Default	0	Units	
Type	16 Bit User Save	Update Rate	N/A
Display Format	Standard	Decimal Places	0
Coding	RW		

Parameter	19.013 Application Menu 2 Read-write Integer 13		
Short description	General read-write integer application parameter		
Mode	Regeneration		
Minimum	-32768	Maximum	32767
Default	0	Units	
Type	16 Bit User Save	Update Rate	N/A
Display Format	Standard	Decimal Places	0
Coding	RW		

Parameter	19.014 Application Menu 2 Read-write Integer 14		
Short description	General read-write integer application parameter		
Mode	Regeneration		
Minimum	-32768	Maximum	32767
Default	0	Units	
Type	16 Bit User Save	Update Rate	N/A
Display Format	Standard	Decimal Places	0
Coding	RW		

Parameter	19.015 Application Menu 2 Read-write Integer 15		
Short description	General read-write integer application parameter		
Mode	Regeneration		
Minimum	-32768	Maximum	32767
Default	0	Units	
Type	16 Bit User Save	Update Rate	N/A
Display Format	Standard	Decimal Places	0
Coding	RW		

Parameter	19.016 Application Menu 2 Read-write Integer 16		
Short description	General read-write integer application parameter		
Mode	Regeneration		
Minimum	-32768	Maximum	32767
Default	0	Units	
Type	16 Bit User Save	Update Rate	N/A
Display Format	Standard	Decimal Places	0
Coding	RW		

Parameter	19.017 Application Menu 2 Read-write Integer 17		
Short description	General read-write integer application parameter		
Mode	Regeneration		
Minimum	-32768	Maximum	32767
Default	0	Units	
Type	16 Bit User Save	Update Rate	N/A
Display Format	Standard	Decimal Places	0
Coding	RW		

Parameter	19.018 Application Menu 2 Read-write Integer 18		
Short description	General read-write integer application parameter		
Mode	Regeneration		
Minimum	-32768	Maximum	32767
Default	0	Units	
Type	16 Bit User Save	Update Rate	N/A
Display Format	Standard	Decimal Places	0
Coding	RW		

Parameter	19.019 Application Menu 2 Read-write Integer 19		
Short description	General read-write integer application parameter		
Mode	Regeneration		
Minimum	-32768	Maximum	32767
Default	0	Units	
Type	16 Bit User Save	Update Rate	N/A
Display Format	Standard	Decimal Places	0
Coding	RW		

Parameter	19.020 Application Menu 2 Read-write Integer 20		
Short description	General read-write integer application parameter		
Mode	Regeneration		
Minimum	-32768	Maximum	32767
Default	0	Units	
Type	16 Bit User Save	Update Rate	N/A
Display Format	Standard	Decimal Places	0
Coding	RW		

Parameter	19.021 Application Menu 2 Read-write Integer 21		
Short description	General read-write integer application parameter		
Mode	Regeneration		
Minimum	-32768	Maximum	32767
Default	0	Units	
Type	16 Bit User Save	Update Rate	N/A
Display Format	Standard	Decimal Places	0
Coding	RW		

Parameter	19.022 Application Menu 2 Read-write Integer 22		
Short description	General read-write integer application parameter		
Mode	Regeneration		
Minimum	-32768	Maximum	32767
Default	0	Units	
Type	16 Bit User Save	Update Rate	N/A
Display Format	Standard	Decimal Places	0
Coding	RW		

Parameter	19.023 Application Menu 2 Read-write Integer 23		
Short description	General read-write integer application parameter		
Mode	Regeneration		
Minimum	-32768	Maximum	32767
Default	0	Units	
Type	16 Bit User Save	Update Rate	N/A
Display Format	Standard	Decimal Places	0
Coding	RW		

Parameter	19.024 Application Menu 2 Read-write Integer 24		
Short description	General read-write integer application parameter		
Mode	Regeneration		
Minimum	-32768	Maximum	32767
Default	0	Units	
Type	16 Bit User Save	Update Rate	N/A
Display Format	Standard	Decimal Places	0
Coding	RW		

Parameter	19.025 Application Menu 2 Read-write Integer 25		
Short description	General read-write integer application parameter		
Mode	Regeneration		
Minimum	-32768	Maximum	32767
Default	0	Units	
Type	16 Bit User Save	Update Rate	N/A
Display Format	Standard	Decimal Places	0
Coding	RW		

Parameter	19.026 Application Menu 2 Read-write Integer 26		
Short description	General read-write integer application parameter		
Mode	Regeneration		
Minimum	-32768	Maximum	32767
Default	0	Units	
Type	16 Bit User Save	Update Rate	N/A
Display Format	Standard	Decimal Places	0
Coding	RW		

Parameter	19.027 Application Menu 2 Read-write Integer 27		
Short description	General read-write integer application parameter		
Mode	Regeneration		
Minimum	-32768	Maximum	32767
Default	0	Units	
Type	16 Bit User Save	Update Rate	N/A
Display Format	Standard	Decimal Places	0
Coding	RW		

Parameter	19.028 Application Menu 2 Read-write Integer 28		
Short description	General read-write integer application parameter		
Mode	Regeneration		
Minimum	-32768	Maximum	32767
Default	0	Units	
Type	16 Bit User Save	Update Rate	N/A
Display Format	Standard	Decimal Places	0
Coding	RW		

Parameter	19.029 Application Menu 2 Read-write Integer 29		
Short description	General read-write integer application parameter		
Mode	Regeneration		
Minimum	-32768	Maximum	32767
Default	0	Units	
Type	16 Bit User Save	Update Rate	N/A
Display Format	Standard	Decimal Places	0
Coding	RW		

Parameter	19.030 Application Menu 2 Read-write Integer 30		
Short description	General read-write integer application parameter		
Mode	Regeneration		
Minimum	-32768	Maximum	32767
Default	0	Units	
Type	16 Bit User Save	Update Rate	N/A
Display Format	Standard	Decimal Places	0
Coding	RW		

Parameter	19.031 Application Menu 2 Read-write bit 31		
Short description	General read-write bit application parameter		
Mode	Regeneration		
Minimum	0	Maximum	1
Default	0	Units	
Type	1 Bit User Save	Update Rate	N/A
Display Format	Standard	Decimal Places	0
Coding	RW		

Parameter	19.032 Application Menu 2 Read-write bit 32		
Short description	General read-write bit application parameter		
Mode	Regeneration		
Minimum	0	Maximum	1
Default	0	Units	
Type	1 Bit User Save	Update Rate	N/A
Display Format	Standard	Decimal Places	0
Coding	RW		

Parameter	19.033 Application Menu 2 Read-write bit 33		
Short description	General read-write bit application parameter		
Mode	Regeneration		
Minimum	0	Maximum	1
Default	0	Units	
Type	1 Bit User Save	Update Rate	N/A
Display Format	Standard	Decimal Places	0
Coding	RW		

Parameter	19.034 Application Menu 2 Read-write bit 34		
Short description	General read-write bit application parameter		
Mode	Regeneration		
Minimum	0	Maximum	1
Default	0	Units	
Type	1 Bit User Save	Update Rate	N/A
Display Format	Standard	Decimal Places	0
Coding	RW		

Parameter	19.035 Application Menu 2 Read-write bit 35		
Short description	General read-write bit application parameter		
Mode	Regeneration		
Minimum	0	Maximum	1
Default	0	Units	
Type	1 Bit User Save	Update Rate	N/A
Display Format	Standard	Decimal Places	0
Coding	RW		

Parameter	19.036 Application Menu 2 Read-write bit 36		
Short description	General read-write bit application parameter		
Mode	Regeneration		
Minimum	0	Maximum	1
Default	0	Units	
Type	1 Bit User Save	Update Rate	N/A
Display Format	Standard	Decimal Places	0
Coding	RW		

Parameter	19.037 Application Menu 2 Read-write bit 37		
Short description	General read-write bit application parameter		
Mode	Regeneration		
Minimum	0	Maximum	1
Default	0	Units	
Type	1 Bit User Save	Update Rate	N/A
Display Format	Standard	Decimal Places	0
Coding	RW		

Parameter	19.038 Application Menu 2 Read-write bit 38		
Short description	General read-write bit application parameter		
Mode	Regeneration		
Minimum	0	Maximum	1
Default	0	Units	
Type	1 Bit User Save	Update Rate	N/A
Display Format	Standard	Decimal Places	0
Coding	RW		

Parameter	19.039 Application Menu 2 Read-write bit 39		
Short description	General read-write bit application parameter		
Mode	Regeneration		
Minimum	0	Maximum	1
Default	0	Units	
Type	1 Bit User Save	Update Rate	N/A
Display Format	Standard	Decimal Places	0
Coding	RW		

Parameter	19.040 Application Menu 2 Read-write bit 40		
Short description	General read-write bit application parameter		
Mode	Regeneration		
Minimum	0	Maximum	1
Default	0	Units	
Type	1 Bit User Save	Update Rate	N/A
Display Format	Standard	Decimal Places	0
Coding	RW		

Parameter	19.041 Application Menu 2 Read-write bit 41		
Short description	General read-write bit application parameter		
Mode	Regeneration		
Minimum	0	Maximum	1
Default	0	Units	
Type	1 Bit User Save	Update Rate	N/A
Display Format	Standard	Decimal Places	0
Coding	RW		

Parameter	19.042 Application Menu 2 Read-write bit 42		
Short description	General read-write bit application parameter		
Mode	Regeneration		
Minimum	0	Maximum	1
Default	0	Units	
Type	1 Bit User Save	Update Rate	N/A
Display Format	Standard	Decimal Places	0
Coding	RW		

Parameter	19.043 Application Menu 2 Read-write bit 43		
Short description	General read-write bit application parameter		
Mode	Regeneration		
Minimum	0	Maximum	1
Default	0	Units	
Type	1 Bit User Save	Update Rate	N/A
Display Format	Standard	Decimal Places	0
Coding	RW		

Parameter	19.044 Application Menu 2 Read-write bit 44		
Short description	General read-write bit application parameter		
Mode	Regeneration		
Minimum	0	Maximum	1
Default	0	Units	
Type	1 Bit User Save	Update Rate	N/A
Display Format	Standard	Decimal Places	0
Coding	RW		

Parameter	19.045 Application Menu 2 Read-write bit 45		
Short description	General read-write bit application parameter		
Mode	Regeneration		
Minimum	0	Maximum	1
Default	0	Units	
Type	1 Bit User Save	Update Rate	N/A
Display Format	Standard	Decimal Places	0
Coding	RW		

Parameter	19.046 Application Menu 2 Read-write bit 46		
Short description	General read-write bit application parameter		
Mode	Regeneration		
Minimum	0	Maximum	1
Default	0	Units	
Type	1 Bit User Save	Update Rate	N/A
Display Format	Standard	Decimal Places	0
Coding	RW		

Parameter	19.047 Application Menu 2 Read-write bit 47		
Short description	General read-write bit application parameter		
Mode	Regeneration		
Minimum	0	Maximum	1
Default	0	Units	
Type	1 Bit User Save	Update Rate	N/A
Display Format	Standard	Decimal Places	0
Coding	RW		

Parameter	19.048 Application Menu 2 Read-write bit 48		
Short description	General read-write bit application parameter		
Mode	Regeneration		
Minimum	0	Maximum	1
Default	0	Units	
Type	1 Bit User Save	Update Rate	N/A
Display Format	Standard	Decimal Places	0
Coding	RW		

Parameter	19.049 Application Menu 2 Read-write bit 49		
Short description	General read-write bit application parameter		
Mode	Regeneration		
Minimum	0	Maximum	1
Default	0	Units	
Type	1 Bit User Save	Update Rate	N/A
Display Format	Standard	Decimal Places	0
Coding	RW		

Parameter	19.050 Application Menu 2 Read-write bit 50		
Short description	General read-write bit application parameter		
Mode	Regeneration		
Minimum	0	Maximum	1
Default	0	Units	
Type	1 Bit User Save	Update Rate	N/A
Display Format	Standard	Decimal Places	0
Coding	RW		

Parameter	19.051 Application Menu 2 Power-down Save Long Integer 51		
Short description	General power-down save long integer application parameter		
Mode	Regeneration		
Minimum	-2147483648	Maximum	2147483647
Default	0	Units	
Type	32 Bit Power Down Save	Update Rate	N/A
Display Format	Standard	Decimal Places	0
Coding	RW		

Parameter	19.052 Application Menu 2 Power-down Save Long Integer 52		
Short description	General power-down save long integer application parameter		
Mode	Regeneration		
Minimum	-2147483648	Maximum	2147483647
Default	0	Units	
Type	32 Bit Power Down Save	Update Rate	N/A
Display Format	Standard	Decimal Places	0
Coding	RW		

Parameter	19.053 Application Menu 2 Power-down Save Long Integer 53		
Short description	General power-down save long integer application parameter		
Mode	Regeneration		
Minimum	-2147483648	Maximum	2147483647
Default	0	Units	
Type	32 Bit Power Down Save	Update Rate	N/A
Display Format	Standard	Decimal Places	0
Coding	RW		

Parameter	19.054 Application Menu 2 Power-down Save Long Integer 54		
Short description	General power-down save long integer application parameter		
Mode	Regeneration		
Minimum	-2147483648	Maximum	2147483647
Default	0	Units	
Type	32 Bit Power Down Save	Update Rate	N/A
Display Format	Standard	Decimal Places	0
Coding	RW		

Menu 20 Single Line Descriptions – Application Menu 3

Mode: Regeneration

Parameter		Range	Default	Type			
20.001	Application Menu 3 Read-write Integer 1	-32768 to 32767	0	RW	Num		
20.002	Application Menu 3 Read-write Integer 2	-32768 to 32767	0	RW	Num		
20.003	Application Menu 3 Read-write Integer 3	-32768 to 32767	0	RW	Num		
20.004	Application Menu 3 Read-write Integer 4	-32768 to 32767	0	RW	Num		
20.005	Application Menu 3 Read-write Integer 5	-32768 to 32767	0	RW	Num		
20.006	Application Menu 3 Read-write Integer 6	-32768 to 32767	0	RW	Num		
20.007	Application Menu 3 Read-write Integer 7	-32768 to 32767	0	RW	Num		
20.008	Application Menu 3 Read-write Integer 8	-32768 to 32767	0	RW	Num		
20.009	Application Menu 3 Read-write Integer 9	-32768 to 32767	0	RW	Num		
20.010	Application Menu 3 Read-write Integer 10	-32768 to 32767	0	RW	Num		
20.011	Application Menu 3 Read-write Integer 11	-32768 to 32767	0	RW	Num		
20.012	Application Menu 3 Read-write Integer 12	-32768 to 32767	0	RW	Num		
20.013	Application Menu 3 Read-write Integer 13	-32768 to 32767	0	RW	Num		
20.014	Application Menu 3 Read-write Integer 14	-32768 to 32767	0	RW	Num		
20.015	Application Menu 3 Read-write Integer 15	-32768 to 32767	0	RW	Num		
20.016	Application Menu 3 Read-write Integer 16	-32768 to 32767	0	RW	Num		
20.017	Application Menu 3 Read-write Integer 17	-32768 to 32767	0	RW	Num		
20.018	Application Menu 3 Read-write Integer 18	-32768 to 32767	0	RW	Num		
20.019	Application Menu 3 Read-write Integer 19	-32768 to 32767	0	RW	Num		
20.020	Application Menu 3 Read-write Integer 20	-32768 to 32767	0	RW	Num		
20.021	Application Menu 3 Read-write Long Integer 21	-2147483648 to 2147483647	0	RW	Num		
20.022	Application Menu 3 Read-write Long Integer 22	-2147483648 to 2147483647	0	RW	Num		
20.023	Application Menu 3 Read-write Long Integer 23	-2147483648 to 2147483647	0	RW	Num		
20.024	Application Menu 3 Read-write Long Integer 24	-2147483648 to 2147483647	0	RW	Num		
20.025	Application Menu 3 Read-write Long Integer 25	-2147483648 to 2147483647	0	RW	Num		
20.026	Application Menu 3 Read-write Long Integer 26	-2147483648 to 2147483647	0	RW	Num		
20.027	Application Menu 3 Read-write Long Integer 27	-2147483648 to 2147483647	0	RW	Num		
20.028	Application Menu 3 Read-write Long Integer 28	-2147483648 to 2147483647	0	RW	Num		
20.029	Application Menu 3 Read-write Long Integer 29	-2147483648 to 2147483647	0	RW	Num		
20.030	Application Menu 3 Read-write Long Integer 30	-2147483648 to 2147483647	0	RW	Num		
20.031	Application Menu 3 Read-write Long Integer 31	-2147483648 to 2147483647	0	RW	Num		
20.032	Application Menu 3 Read-write Long Integer 32	-2147483648 to 2147483647	0	RW	Num		
20.033	Application Menu 3 Read-write Long Integer 33	-2147483648 to 2147483647	0	RW	Num		
20.034	Application Menu 3 Read-write Long Integer 34	-2147483648 to 2147483647	0	RW	Num		
20.035	Application Menu 3 Read-write Long Integer 35	-2147483648 to 2147483647	0	RW	Num		
20.036	Application Menu 3 Read-write Long Integer 36	-2147483648 to 2147483647	0	RW	Num		
20.037	Application Menu 3 Read-write Long Integer 37	-2147483648 to 2147483647	0	RW	Num		
20.038	Application Menu 3 Read-write Long Integer 38	-2147483648 to 2147483647	0	RW	Num		
20.039	Application Menu 3 Read-write Long Integer 39	-2147483648 to 2147483647	0	RW	Num		
20.040	Application Menu 3 Read-write Long Integer 40	-2147483648 to 2147483647	0	RW	Num		

RW	Read / Write	RO	Read-only	Bit	Bit parameter	Txt	Text string	Date	Date parameter	Time	Time parameter
Chr	Character parameter	Bin	Binary parameter	IP	IP address	Mac	MAC address	Ver	Version number	SMP	Slot, menu, parameter
Num	Number parameter	DE	Destination	ND	No default value	RA	Rating dependent	NC	Non-copyable	PT	Protected
Fl	Filtered	US	User save	PS	Power-down save						

Menu 20 – Application Menu 3

Mode: Regeneration

See the introduction to menu 18.

Parameter	20.001 Application Menu 3 Read-write Integer 1		
Short description	General read-write integer application parameter		
Mode	Regeneration		
Minimum	-32768	Maximum	32767
Default	0	Units	
Type	16 Bit Volatile	Update Rate	N/A
Display Format	Standard	Decimal Places	0
Coding	RW		

Parameter	20.002 Application Menu 3 Read-write Integer 2		
Short description	General read-write integer application parameter		
Mode	Regeneration		
Minimum	-32768	Maximum	32767
Default	0	Units	
Type	16 Bit Volatile	Update Rate	N/A
Display Format	Standard	Decimal Places	0
Coding	RW		

Parameter	20.003 Application Menu 3 Read-write Integer 3		
Short description	General read-write integer application parameter		
Mode	Regeneration		
Minimum	-32768	Maximum	32767
Default	0	Units	
Type	16 Bit Volatile	Update Rate	N/A
Display Format	Standard	Decimal Places	0
Coding	RW		

Parameter	20.004 Application Menu 3 Read-write Integer 4		
Short description	General read-write integer application parameter		
Mode	Regeneration		
Minimum	-32768	Maximum	32767
Default	0	Units	
Type	16 Bit Volatile	Update Rate	N/A
Display Format	Standard	Decimal Places	0
Coding	RW		

Parameter	20.005 Application Menu 3 Read-write Integer 5		
Short description	General read-write integer application parameter		
Mode	Regeneration		
Minimum	-32768	Maximum	32767
Default	0	Units	
Type	16 Bit Volatile	Update Rate	N/A
Display Format	Standard	Decimal Places	0
Coding	RW		

Parameter	20.006 Application Menu 3 Read-write Integer 6		
Short description	General read-write integer application parameter		
Mode	Regeneration		
Minimum	-32768	Maximum	32767
Default	0	Units	
Type	16 Bit Volatile	Update Rate	N/A
Display Format	Standard	Decimal Places	0
Coding	RW		

Parameter	20.007 Application Menu 3 Read-write Integer 7		
Short description	General read-write integer application parameter		
Mode	Regeneration		
Minimum	-32768	Maximum	32767
Default	0	Units	
Type	16 Bit Volatile	Update Rate	N/A
Display Format	Standard	Decimal Places	0
Coding	RW		

Parameter	20.008 Application Menu 3 Read-write Integer 8		
Short description	General read-write integer application parameter		
Mode	Regeneration		
Minimum	-32768	Maximum	32767
Default	0	Units	
Type	16 Bit Volatile	Update Rate	N/A
Display Format	Standard	Decimal Places	0
Coding	RW		

Parameter	20.009 Application Menu 3 Read-write Integer 9		
Short description	General read-write integer application parameter		
Mode	Regeneration		
Minimum	-32768	Maximum	32767
Default	0	Units	
Type	16 Bit Volatile	Update Rate	N/A
Display Format	Standard	Decimal Places	0
Coding	RW		

Parameter	20.010 Application Menu 3 Read-write Integer 10		
Short description	General read-write integer application parameter		
Mode	Regeneration		
Minimum	-32768	Maximum	32767
Default	0	Units	
Type	16 Bit Volatile	Update Rate	N/A
Display Format	Standard	Decimal Places	0
Coding	RW		

Parameter	20.011 Application Menu 3 Read-write Integer 11		
Short description	General read-write integer application parameter		
Mode	Regeneration		
Minimum	-32768	Maximum	32767
Default	0	Units	
Type	16 Bit Volatile	Update Rate	N/A
Display Format	Standard	Decimal Places	0
Coding	RW		

Parameter	20.012 Application Menu 3 Read-write Integer 12		
Short description	General read-write integer application parameter		
Mode	Regeneration		
Minimum	-32768	Maximum	32767
Default	0	Units	
Type	16 Bit Volatile	Update Rate	N/A
Display Format	Standard	Decimal Places	0
Coding	RW		

Parameter	20.013 Application Menu 3 Read-write Integer 13		
Short description	General read-write integer application parameter		
Mode	Regeneration		
Minimum	-32768	Maximum	32767
Default	0	Units	
Type	16 Bit Volatile	Update Rate	N/A
Display Format	Standard	Decimal Places	0
Coding	RW		

Parameter	20.014 Application Menu 3 Read-write Integer 14		
Short description	General read-write integer application parameter		
Mode	Regeneration		
Minimum	-32768	Maximum	32767
Default	0	Units	
Type	16 Bit Volatile	Update Rate	N/A
Display Format	Standard	Decimal Places	0
Coding	RW		

Parameter	20.015 Application Menu 3 Read-write Integer 15		
Short description	General read-write integer application parameter		
Mode	Regeneration		
Minimum	-32768	Maximum	32767
Default	0	Units	
Type	16 Bit Volatile	Update Rate	N/A
Display Format	Standard	Decimal Places	0
Coding	RW		

Parameter	20.016 Application Menu 3 Read-write Integer 16		
Short description	General read-write integer application parameter		
Mode	Regeneration		
Minimum	-32768	Maximum	32767
Default	0	Units	
Type	16 Bit Volatile	Update Rate	N/A
Display Format	Standard	Decimal Places	0
Coding	RW		

Parameter	20.017 Application Menu 3 Read-write Integer 17		
Short description	General read-write integer application parameter		
Mode	Regeneration		
Minimum	-32768	Maximum	32767
Default	0	Units	
Type	16 Bit Volatile	Update Rate	N/A
Display Format	Standard	Decimal Places	0
Coding	RW		

Parameter	20.018 Application Menu 3 Read-write Integer 18		
Short description	General read-write integer application parameter		
Mode	Regeneration		
Minimum	-32768	Maximum	32767
Default	0	Units	
Type	16 Bit Volatile	Update Rate	N/A
Display Format	Standard	Decimal Places	0
Coding	RW		

Parameter	20.019 Application Menu 3 Read-write Integer 19		
Short description	General read-write integer application parameter		
Mode	Regeneration		
Minimum	-32768	Maximum	32767
Default	0	Units	
Type	16 Bit Volatile	Update Rate	N/A
Display Format	Standard	Decimal Places	0
Coding	RW		

Parameter	20.020 Application Menu 3 Read-write Integer 20		
Short description	General read-write integer application parameter		
Mode	Regeneration		
Minimum	-32768	Maximum	32767
Default	0	Units	
Type	16 Bit Volatile	Update Rate	N/A
Display Format	Standard	Decimal Places	0
Coding	RW		

Parameter	20.021 Application Menu 3 Read-write Long Integer 21		
Short description	General read-write long integer application parameter		
Mode	Regeneration		
Minimum	-2147483648	Maximum	2147483647
Default	0	Units	
Type	32 Bit Volatile	Update Rate	N/A
Display Format	Standard	Decimal Places	0
Coding	RW		

Parameter	20.022 Application Menu 3 Read-write Long Integer 22		
Short description	General read-write long integer application parameter		
Mode	Regeneration		
Minimum	-2147483648	Maximum	2147483647
Default	0	Units	
Type	32 Bit Volatile	Update Rate	N/A
Display Format	Standard	Decimal Places	0
Coding	RW		

Parameter	20.023 Application Menu 3 Read-write Long Integer 23		
Short description	General read-write long integer application parameter		
Mode	Regeneration		
Minimum	-2147483648	Maximum	2147483647
Default	0	Units	
Type	32 Bit Volatile	Update Rate	N/A
Display Format	Standard	Decimal Places	0
Coding	RW		

Parameter	20.024 Application Menu 3 Read-write Long Integer 24		
Short description	General read-write long integer application parameter		
Mode	Regeneration		
Minimum	-2147483648	Maximum	2147483647
Default	0	Units	
Type	32 Bit Volatile	Update Rate	N/A
Display Format	Standard	Decimal Places	0
Coding	RW		

Parameter	20.025 Application Menu 3 Read-write Long Integer 25		
Short description	General read-write long integer application parameter		
Mode	Regeneration		
Minimum	-2147483648	Maximum	2147483647
Default	0	Units	
Type	32 Bit Volatile	Update Rate	N/A
Display Format	Standard	Decimal Places	0
Coding	RW		

Parameter	20.026 Application Menu 3 Read-write Long Integer 26		
Short description	General read-write long integer application parameter		
Mode	Regeneration		
Minimum	-2147483648	Maximum	2147483647
Default	0	Units	
Type	32 Bit Volatile	Update Rate	N/A
Display Format	Standard	Decimal Places	0
Coding	RW		

Parameter	20.027 Application Menu 3 Read-write Long Integer 27		
Short description	General read-write long integer application parameter		
Mode	Regeneration		
Minimum	-2147483648	Maximum	2147483647
Default	0	Units	
Type	32 Bit Volatile	Update Rate	N/A
Display Format	Standard	Decimal Places	0
Coding	RW		

Parameter	20.028 Application Menu 3 Read-write Long Integer 28		
Short description	General read-write long integer application parameter		
Mode	Regeneration		
Minimum	-2147483648	Maximum	2147483647
Default	0	Units	
Type	32 Bit Volatile	Update Rate	N/A
Display Format	Standard	Decimal Places	0
Coding	RW		

Parameter	20.029 Application Menu 3 Read-write Long Integer 29		
Short description	General read-write long integer application parameter		
Mode	Regeneration		
Minimum	-2147483648	Maximum	2147483647
Default	0	Units	
Type	32 Bit Volatile	Update Rate	N/A
Display Format	Standard	Decimal Places	0
Coding	RW		

Parameter	20.030 Application Menu 3 Read-write Long Integer 30		
Short description	General read-write long integer application parameter		
Mode	Regeneration		
Minimum	-2147483648	Maximum	2147483647
Default	0	Units	
Type	32 Bit Volatile	Update Rate	N/A
Display Format	Standard	Decimal Places	0
Coding	RW		

Parameter	20.031 Application Menu 3 Read-write Long Integer 31		
Short description	General read-write long integer application parameter		
Mode	Regeneration		
Minimum	-2147483648	Maximum	2147483647
Default	0	Units	
Type	32 Bit Volatile	Update Rate	N/A
Display Format	Standard	Decimal Places	0
Coding	RW		

Parameter	20.032 Application Menu 3 Read-write Long Integer 32		
Short description	General read-write long integer application parameter		
Mode	Regeneration		
Minimum	-2147483648	Maximum	2147483647
Default	0	Units	
Type	32 Bit Volatile	Update Rate	N/A
Display Format	Standard	Decimal Places	0
Coding	RW		

Parameter	20.033 Application Menu 3 Read-write Long Integer 33		
Short description	General read-write long integer application parameter		
Mode	Regeneration		
Minimum	-2147483648	Maximum	2147483647
Default	0	Units	
Type	32 Bit Volatile	Update Rate	N/A
Display Format	Standard	Decimal Places	0
Coding	RW		

Parameter	20.034 Application Menu 3 Read-write Long Integer 34		
Short description	General read-write long integer application parameter		
Mode	Regeneration		
Minimum	-2147483648	Maximum	2147483647
Default	0	Units	
Type	32 Bit Volatile	Update Rate	N/A
Display Format	Standard	Decimal Places	0
Coding	RW		

Parameter	20.035 Application Menu 3 Read-write Long Integer 35		
Short description	General read-write long integer application parameter		
Mode	Regeneration		
Minimum	-2147483648	Maximum	2147483647
Default	0	Units	
Type	32 Bit Volatile	Update Rate	N/A
Display Format	Standard	Decimal Places	0
Coding	RW		

Parameter	20.036 Application Menu 3 Read-write Long Integer 36		
Short description	General read-write long integer application parameter		
Mode	Regeneration		
Minimum	-2147483648	Maximum	2147483647
Default	0	Units	
Type	32 Bit Volatile	Update Rate	N/A
Display Format	Standard	Decimal Places	0
Coding	RW		

Parameter	20.037 Application Menu 3 Read-write Long Integer 37		
Short description	General read-write long integer application parameter		
Mode	Regeneration		
Minimum	-2147483648	Maximum	2147483647
Default	0	Units	
Type	32 Bit Volatile	Update Rate	N/A
Display Format	Standard	Decimal Places	0
Coding	RW		

Parameter	20.038 Application Menu 3 Read-write Long Integer 38		
Short description	General read-write long integer application parameter		
Mode	Regeneration		
Minimum	-2147483648	Maximum	2147483647
Default	0	Units	
Type	32 Bit Volatile	Update Rate	N/A
Display Format	Standard	Decimal Places	0
Coding	RW		

Parameter	20.039 Application Menu 3 Read-write Long Integer 39		
Short description	General read-write long integer application parameter		
Mode	Regeneration		
Minimum	-2147483648	Maximum	2147483647
Default	0	Units	
Type	32 Bit Volatile	Update Rate	N/A
Display Format	Standard	Decimal Places	0
Coding	RW		

Parameter	20.040 Application Menu 3 Read-write Long Integer 40		
Short description	General read-write long integer application parameter		
Mode	Regeneration		
Minimum	-2147483648	Maximum	2147483647
Default	0	Units	
Type	32 Bit Volatile	Update Rate	N/A
Display Format	Standard	Decimal Places	0
Coding	RW		

Menu 22 Single Line Descriptions – *Menu 0 Set-up*

Mode: Regeneration

Parameter	Range	Default	Type						
			RW	Num			PT	US	
22.001	Parameter 00.001 Set-up	0.000 to 59.999						PT	US
22.002	Parameter 00.002 Set-up	0.000 to 59.999						PT	US
22.003	Parameter 00.003 Set-up	0.000 to 59.999						PT	US
22.004	Parameter 00.004 Set-up	0.000 to 59.999						PT	US
22.005	Parameter 00.005 Set-up	0.000 to 59.999						PT	US
22.006	Parameter 00.006 Set-up	0.000 to 59.999						PT	US
22.007	Parameter 00.007 Set-up	0.000 to 59.999						PT	US
22.008	Parameter 00.008 Set-up	0.000 to 59.999						PT	US
22.009	Parameter 00.009 Set-up	0.000 to 59.999						PT	US
22.010	Parameter 00.010 Set-up	0.000 to 59.999						PT	US
22.011	Parameter 00.011 Set-up	0.000 to 59.999						PT	US
22.012	Parameter 00.012 Set-up	0.000 to 59.999						PT	US
22.013	Parameter 00.013 Set-up	0.000 to 59.999						PT	US
22.014	Parameter 00.014 Set-up	0.000 to 59.999						PT	US
22.015	Parameter 00.015 Set-up	0.000 to 59.999						PT	US
22.016	Parameter 00.016 Set-up	0.000 to 59.999						PT	US
22.017	Parameter 00.017 Set-up	0.000 to 59.999						PT	US
22.018	Parameter 00.018 Set-up	0.000 to 59.999						PT	US
22.019	Parameter 00.019 Set-up	0.000 to 59.999						PT	US
22.020	Parameter 00.020 Set-up	0.000 to 59.999						PT	US
22.021	Parameter 00.021 Set-up	0.000 to 59.999						PT	US
22.022	Parameter 00.022 Set-up	0.000 to 59.999						PT	US
22.023	Parameter 00.023 Set-up	0.000 to 59.999						PT	US
22.024	Parameter 00.024 Set-up	0.000 to 59.999						PT	US
22.025	Parameter 00.025 Set-up	0.000 to 59.999						PT	US
22.026	Parameter 00.026 Set-up	0.000 to 59.999						PT	US
22.027	Parameter 00.027 Set-up	0.000 to 59.999						PT	US
22.028	Parameter 00.028 Set-up	0.000 to 59.999						PT	US
22.029	Parameter 00.029 Set-up	0.000 to 59.999						PT	US
22.030	Parameter 00.030 Set-up	0.000 to 59.999						PT	US
22.031	Parameter 00.031 Set-up	0.000 to 59.999						PT	US
22.032	Parameter 00.032 Set-up	0.000 to 59.999						PT	US
22.033	Parameter 00.033 Set-up	0.000 to 59.999						PT	US
22.034	Parameter 00.034 Set-up	0.000 to 59.999						PT	US
22.035	Parameter 00.035 Set-up	0.000 to 59.999						PT	US
22.036	Parameter 00.036 Set-up	0.000 to 59.999						PT	US
22.037	Parameter 00.037 Set-up	0.000 to 59.999						PT	US
22.038	Parameter 00.038 Set-up	0.000 to 59.999						PT	US
22.039	Parameter 00.039 Set-up	0.000 to 59.999						PT	US
22.040	Parameter 00.040 Set-up	0.000 to 59.999						PT	US
22.041	Parameter 00.041 Set-up	0.000 to 59.999						PT	US
22.042	Parameter 00.042 Set-up	0.000 to 59.999						PT	US
22.043	Parameter 00.043 Set-up	0.000 to 59.999						PT	US
22.044	Parameter 00.044 Set-up	0.000 to 59.999						PT	US
22.045	Parameter 00.045 Set-up	0.000 to 59.999						PT	US
22.046	Parameter 00.046 Set-up	0.000 to 59.999						PT	US
22.047	Parameter 00.047 Set-up	0.000 to 59.999						PT	US
22.048	Parameter 00.048 Set-up	0.000 to 59.999						PT	US
22.049	Parameter 00.049 Set-up	0.000 to 59.999						PT	US
22.050	Parameter 00.050 Set-up	0.000 to 59.999						PT	US
22.051	Parameter 00.051 Set-up	0.000 to 59.999						PT	US
22.052	Parameter 00.052 Set-up	0.000 to 59.999						PT	US
22.053	Parameter 00.053 Set-up	0.000 to 59.999						PT	US
22.054	Parameter 00.054 Set-up	0.000 to 59.999						PT	US
22.055	Parameter 00.055 Set-up	0.000 to 59.999						PT	US
22.056	Parameter 00.056 Set-up	0.000 to 59.999						PT	US
22.057	Parameter 00.057 Set-up	0.000 to 59.999						PT	US
22.058	Parameter 00.058 Set-up	0.000 to 59.999						PT	US
22.059	Parameter 00.059 Set-up	0.000 to 59.999						PT	US
22.060	Parameter 00.060 Set-up	0.000 to 59.999						PT	US
22.061	Parameter 00.061 Set-up	0.000 to 59.999						PT	US
22.062	Parameter 00.062 Set-up	0.000 to 59.999						PT	US
22.063	Parameter 00.063 Set-up	0.000 to 59.999						PT	US

22.064	Parameter 00.064 Set-up	0.000 to 59.999	0.000	RW	Num			PT	US
22.065	Parameter 00.065 Set-up	0.000 to 59.999	0.000	RW	Num			PT	US
22.066	Parameter 00.066 Set-up	0.000 to 59.999	0.000	RW	Num			PT	US
22.067	Parameter 00.067 Set-up	0.000 to 59.999	0.000	RW	Num			PT	US
22.068	Parameter 00.068 Set-up	0.000 to 59.999	0.000	RW	Num			PT	US
22.069	Parameter 00.069 Set-up	0.000 to 59.999	0.000	RW	Num			PT	US
22.070	Parameter 00.070 Set-up	0.000 to 59.999	0.000	RW	Num			PT	US
22.071	Parameter 00.071 Set-up	0.000 to 59.999	0.000	RW	Num			PT	US
22.072	Parameter 00.072 Set-up	0.000 to 59.999	0.000	RW	Num			PT	US
22.073	Parameter 00.073 Set-up	0.000 to 59.999	0.000	RW	Num			PT	US
22.074	Parameter 00.074 Set-up	0.000 to 59.999	0.000	RW	Num			PT	US
22.075	Parameter 00.075 Set-up	0.000 to 59.999	0.000	RW	Num			PT	US
22.076	Parameter 00.076 Set-up	0.000 to 59.999	0.000	RW	Num			PT	US
22.077	Parameter 00.077 Set-up	0.000 to 59.999	0.000	RW	Num			PT	US
22.078	Parameter 00.078 Set-up	0.000 to 59.999	0.000	RW	Num			PT	US
22.079	Parameter 00.079 Set-up	0.000 to 59.999	0.000	RW	Num			PT	US
22.080	Parameter 00.080 Set-up	0.000 to 59.999	0.000	RW	Num			PT	US

RW	Read / Write	RO	Read-only	Bit	Bit parameter	Txt	Text string	Date	Date parameter	Time	Time parameter
Chr	Character parameter	Bin	Binary parameter	IP	IP address	Mac	MAC address	Ver	Version number	SMP	Slot, menu, parameter
Num	Number parameter	DE	Destination	ND	No default value	RA	Rating dependent	NC	Non-copyable	PT	Protected
FI	Filtered	US	User save	PS	Power-down save						

Menu 22 – Menu 0 Set-up

Mode: Regeneration

The parameters in this menu are used to set up which parameters are shown in Menu 0.

Parameter	22.001 Parameter 00.001 Set-up		
Short description	Defines the parameter to be shown in 00.001		
Mode	Regeneration		
Minimum	0.000	Maximum	59.999
Default	3.005	Units	
Type	16 Bit User Save	Update Rate	Background read
Display Format	Standard	Decimal Places	3
Coding	RW, PT, BU		

Each parameter is used to set up the equivalent parameter in Menu 0, for example *Parameter 00.001 Set-up* (22.001) is used to set up which parameter is shown in *Menu 0 Parameter 1* (00.001), etc. 80 selectable Menu 0 parameters (00.001 to 00.080) and equivalent set-up parameters (22.001 to 22.080) are provided. When a Menu 0 set-up parameter is set to 00.000 or a value that is not a valid parameter outside Menu 0, the equivalent Menu 0 parameter is not visible. If a parameter has an equivalent motor 2 parameter in Menu 21 then when *Motor 2 Active* (21.015) = 0 the original parameter is displayed, but when *Motor 2 Active* (21.015) = 1 the equivalent motor 2 parameter from Menu 21 is displayed.

Parameter	22.002 Parameter 00.002 Set-up		
Short description	Defines the parameter to be shown in 00.002		
Mode	Regeneration		
Minimum	0.000	Maximum	59.999
Default	3.006	Units	
Type	16 Bit User Save	Update Rate	Background read
Display Format	Standard	Decimal Places	3
Coding	RW, PT, BU		

See *Parameter 00.001 Set-up* (22.001).

Parameter	22.003 Parameter 00.003 Set-up		
Short description	Defines the parameter to be shown in 00.003		
Mode	Regeneration		
Minimum	0.000	Maximum	59.999
Default	3.009	Units	
Type	16 Bit User Save	Update Rate	Background read
Display Format	Standard	Decimal Places	3
Coding	RW, PT, BU		

See *Parameter 00.001 Set-up* (22.001).

Parameter	22.004 Parameter 00.004 Set-up		
Short description	Defines the parameter to be shown in 00.004		
Mode	Regeneration		
Minimum	0.000	Maximum	59.999
Default	5.005	Units	
Type	16 Bit User Save	Update Rate	Background read
Display Format	Standard	Decimal Places	3
Coding	RW, PT, BU		

See *Parameter 00.001 Set-up* (22.001).

Parameter	22.005 Parameter 00.005 Set-up		
Short description	Defines the parameter to be shown in 00.005		
Mode	Regeneration		
Minimum	0.000	Maximum	59.999
Default	5.002	Units	
Type	16 Bit User Save	Update Rate	Background read
Display Format	Standard	Decimal Places	3
Coding	RW, PT, BU		

See *Parameter 00.001 Set-up* (22.001).

Parameter	22.006 Parameter 00.006 Set-up		
Short description	Defines the parameter to be shown in 00.006		
Mode	Regeneration		
Minimum	0.000	Maximum	59.999
Default	3.003	Units	
Type	16 Bit User Save	Update Rate	Background read
Display Format	Standard	Decimal Places	3
Coding	RW, PT, BU		

See *Parameter 00.001 Set-up* (22.001).

Parameter	22.007 Parameter 00.007 Set-up		
Short description	Defines the parameter to be shown in 00.007		
Mode	Regeneration		
Minimum	0.000	Maximum	59.999
Default	3.004	Units	
Type	16 Bit User Save	Update Rate	Background read
Display Format	Standard	Decimal Places	3
Coding	RW, PT, BU		

See *Parameter 00.001 Set-up* (22.001).

Parameter	22.008 Parameter 00.008 Set-up		
Short description	Defines the parameter to be shown in 00.008		
Mode	Regeneration		
Minimum	0.000	Maximum	59.999
Default	3.007	Units	
Type	16 Bit User Save	Update Rate	Background read
Display Format	Standard	Decimal Places	3
Coding	RW, PT, BU		

See *Parameter 00.001 Set-up* (22.001).

Parameter	22.009 Parameter 00.009 Set-up		
Short description	Defines the parameter to be shown in 00.009		
Mode	Regeneration		
Minimum	0.000	Maximum	59.999
Default	3.008	Units	
Type	16 Bit User Save	Update Rate	Background read
Display Format	Standard	Decimal Places	3
Coding	RW, PT, BU		

See *Parameter 00.001 Set-up* (22.001).

Parameter	22.010 Parameter 00.010 Set-up		
Short description	Defines the parameter to be shown in 00.010		
Mode	Regeneration		
Minimum	0.000	Maximum	59.999
Default	3.010	Units	
Type	16 Bit User Save	Update Rate	Background read
Display Format	Standard	Decimal Places	3
Coding	RW, PT, BU		

See *Parameter 00.001 Set-up* (22.001).

Parameter	22.011 Parameter 00.011 Set-up		
Short description	Defines the parameter to be shown in 00.011		
Mode	Regeneration		
Minimum	0.000	Maximum	59.999
Default	5.001	Units	
Type	16 Bit User Save	Update Rate	Background read
Display Format	Standard	Decimal Places	3
Coding	RW, PT, BU		

See *Parameter 00.001 Set-up* (22.001).

Parameter	22.012 Parameter 00.012 Set-up		
Short description	Defines the parameter to be shown in 00.012		
Mode	Regeneration		
Minimum	0.000	Maximum	59.999
Default	4.001	Units	
Type	16 Bit User Save	Update Rate	Background read
Display Format	Standard	Decimal Places	3
Coding	RW, PT, BU		

See *Parameter 00.001 Set-up* (22.001).

Parameter	22.013 Parameter 00.013 Set-up		
Short description	Defines the parameter to be shown in 00.013		
Mode	Regeneration		
Minimum	0.000	Maximum	59.999
Default	4.002	Units	
Type	16 Bit User Save	Update Rate	Background read
Display Format	Standard	Decimal Places	3
Coding	RW, PT, BU		

See *Parameter 00.001 Set-up* (22.001).

Parameter	22.014 Parameter 00.014 Set-up		
Short description	Defines the parameter to be shown in 00.014		
Mode	Regeneration		
Minimum	0.000	Maximum	59.999
Default	5.003	Units	
Type	16 Bit User Save	Update Rate	Background read
Display Format	Standard	Decimal Places	3
Coding	RW, PT, BU		

See *Parameter 00.001 Set-up* (22.001).

Parameter	22.015 Parameter 00.015 Set-up		
Short description	Defines the parameter to be shown in 00.015		
Mode	Regeneration		
Minimum	0.000	Maximum	59.999
Default	3.001	Units	
Type	16 Bit User Save	Update Rate	Background read
Display Format	Standard	Decimal Places	3
Coding	RW, PT, BU		

See *Parameter 00.001 Set-up* (22.001).

Parameter	22.016 Parameter 00.016 Set-up		
Short description	Defines the parameter to be shown in 00.016		
Mode	Regeneration		
Minimum	0.000	Maximum	59.999
Default	3.002	Units	
Type	16 Bit User Save	Update Rate	Background read
Display Format	Standard	Decimal Places	3
Coding	RW, PT, BU		

See *Parameter 00.001 Set-up* (22.001).

Parameter	22.017 Parameter 00.017 Set-up		
Short description	Defines the parameter to be shown in 00.017		
Mode	Regeneration		
Minimum	0.000	Maximum	59.999
Default	4.008	Units	
Type	16 Bit User Save	Update Rate	Background read
Display Format	Standard	Decimal Places	3
Coding	RW, PT, BU		

See *Parameter 00.001 Set-up* (22.001).

Parameter	22.018 Parameter 00.018 Set-up		
Short description	Defines the parameter to be shown in 00.018		
Mode	Regeneration		
Minimum	0.000	Maximum	59.999
Default	0.000	Units	
Type	16 Bit User Save	Update Rate	Background read
Display Format	Standard	Decimal Places	3
Coding	RW, PT, BU		

See *Parameter 00.001 Set-up* (22.001).

Parameter	22.019 Parameter 00.019 Set-up		
Short description	Defines the parameter to be shown in 00.019		
Mode	Regeneration		
Minimum	0.000	Maximum	59.999
Default	0.000	Units	
Type	16 Bit User Save	Update Rate	Background read
Display Format	Standard	Decimal Places	3
Coding	RW, PT, BU		

See *Parameter 00.001 Set-up* (22.001).

Parameter	22.020 Parameter 00.020 Set-up		
Short description	Defines the parameter to be shown in 00.020		
Mode	Regeneration		
Minimum	0.000	Maximum	59.999
Default	0.000	Units	
Type	16 Bit User Save	Update Rate	Background read
Display Format	Standard	Decimal Places	3
Coding	RW, PT, BU		

See *Parameter 00.001 Set-up* (22.001).

Parameter	22.021 Parameter 00.021 Set-up		
Short description	Defines the parameter to be shown in 00.021		
Mode	Regeneration		
Minimum	0.000	Maximum	59.999
Default	0.000	Units	
Type	16 Bit User Save	Update Rate	Background read
Display Format	Standard	Decimal Places	3
Coding	RW, PT, BU		

See *Parameter 00.001 Set-up* (22.001).

Parameter	22.022 Parameter 00.022 Set-up		
Short description	Defines the parameter to be shown in 00.022		
Mode	Regeneration		
Minimum	0.000	Maximum	59.999
Default	0.000	Units	
Type	16 Bit User Save	Update Rate	Background read
Display Format	Standard	Decimal Places	3
Coding	RW, PT, BU		

See *Parameter 00.001 Set-up* (22.001).

Parameter	22.023 Parameter 00.023 Set-up		
Short description	Defines the parameter to be shown in 00.023		
Mode	Regeneration		
Minimum	0.000	Maximum	59.999
Default	0.000	Units	
Type	16 Bit User Save	Update Rate	Background read
Display Format	Standard	Decimal Places	3
Coding	RW, PT, BU		

See *Parameter 00.001 Set-up* (22.001).

Parameter	22.024 Parameter 00.024 Set-up		
Short description	Defines the parameter to be shown in 00.024		
Mode	Regeneration		
Minimum	0.000	Maximum	59.999
Default	0.000	Units	
Type	16 Bit User Save	Update Rate	Background read
Display Format	Standard	Decimal Places	3
Coding	RW, PT, BU		

See *Parameter 00.001 Set-up* (22.001).

Parameter	22.025 Parameter 00.025 Set-up		
Short description	Defines the parameter to be shown in 00.025		
Mode	Regeneration		
Minimum	0.000	Maximum	59.999
Default	0.000	Units	
Type	16 Bit User Save	Update Rate	Background read
Display Format	Standard	Decimal Places	3
Coding	RW, PT, BU		

See *Parameter 00.001 Set-up* (22.001).

Parameter	22.026 Parameter 00.026 Set-up		
Short description	Defines the parameter to be shown in 00.026		
Mode	Regeneration		
Minimum	0.000	Maximum	59.999
Default	0.000	Units	
Type	16 Bit User Save	Update Rate	Background read
Display Format	Standard	Decimal Places	3
Coding	RW, PT, BU		

See *Parameter 00.001 Set-up* (22.001).

Parameter	22.027 Parameter 00.027 Set-up		
Short description	Defines the parameter to be shown in 00.027		
Mode	Regeneration		
Minimum	0.000	Maximum	59.999
Default	0.000	Units	
Type	16 Bit User Save	Update Rate	Background read
Display Format	Standard	Decimal Places	3
Coding	RW, PT, BU		

See *Parameter 00.001 Set-up* (22.001).

Parameter	22.028 Parameter 00.028 Set-up		
Short description	Defines the parameter to be shown in 00.028		
Mode	Regeneration		
Minimum	0.000	Maximum	59.999
Default	0.000	Units	
Type	16 Bit User Save	Update Rate	Background read
Display Format	Standard	Decimal Places	3
Coding	RW, PT, BU		

See *Parameter 00.001 Set-up* (22.001).

Parameter	22.029 Parameter 00.029 Set-up		
Short description	Defines the parameter to be shown in 00.029		
Mode	Regeneration		
Minimum	0.000	Maximum	59.999
Default	11.036	Units	
Type	16 Bit User Save	Update Rate	Background read
Display Format	Standard	Decimal Places	3
Coding	RW, PT, BU		

See *Parameter 00.001 Set-up* (22.001).

Parameter	22.030 Parameter 00.030 Set-up		
Short description	Defines the parameter to be shown in 00.030		
Mode	Regeneration		
Minimum	0.000	Maximum	59.999
Default	11.042	Units	
Type	16 Bit User Save	Update Rate	Background read
Display Format	Standard	Decimal Places	3
Coding	RW, PT, BU		

See *Parameter 00.001 Set-up* (22.001).

Parameter	22.031 Parameter 00.031 Set-up		
Short description	Defines the parameter to be shown in 00.031		
Mode	Regeneration		
Minimum	0.000	Maximum	59.999
Default	11.033	Units	
Type	16 Bit User Save	Update Rate	Background read
Display Format	Standard	Decimal Places	3
Coding	RW, PT, BU		

See *Parameter 00.001 Set-up* (22.001).

Parameter	22.032 Parameter 00.032 Set-up		
Short description	Defines the parameter to be shown in 00.032		
Mode	Regeneration		
Minimum	0.000	Maximum	59.999
Default	11.032	Units	
Type	16 Bit User Save	Update Rate	Background read
Display Format	Standard	Decimal Places	3
Coding	RW, PT, BU		

See *Parameter 00.001 Set-up* (22.001).

Parameter	22.033 Parameter 00.033 Set-up		
Short description	Defines the parameter to be shown in 00.033		
Mode	Regeneration		
Minimum	0.000	Maximum	59.999
Default	0.000	Units	
Type	16 Bit User Save	Update Rate	Background read
Display Format	Standard	Decimal Places	3
Coding	RW, PT, BU		

See *Parameter 00.001 Set-up* (22.001).

Parameter	22.034 Parameter 00.034 Set-up		
Short description	Defines the parameter to be shown in 00.034		
Mode	Regeneration		
Minimum	0.000	Maximum	59.999
Default	11.030	Units	
Type	16 Bit User Save	Update Rate	Background read
Display Format	Standard	Decimal Places	3
Coding	RW, PT, BU		

See *Parameter 00.001 Set-up* (22.001).

Parameter	22.035 Parameter 00.035 Set-up		
Short description	Defines the parameter to be shown in 00.035		
Mode	Regeneration		
Minimum	0.000	Maximum	59.999
Default	0.000	Units	
Type	16 Bit User Save	Update Rate	Background read
Display Format	Standard	Decimal Places	3
Coding	RW, PT, BU		

See *Parameter 00.001 Set-up* (22.001).

Parameter	22.036 Parameter 00.036 Set-up		
Short description	Defines the parameter to be shown in 00.036		
Mode	Regeneration		
Minimum	0.000	Maximum	59.999
Default	0.000	Units	
Type	16 Bit User Save	Update Rate	Background read
Display Format	Standard	Decimal Places	3
Coding	RW, PT, BU		

See *Parameter 00.001 Set-up* (22.001).

Parameter	22.037 Parameter 00.037 Set-up		
Short description	Defines the parameter to be shown in 00.037		
Mode	Regeneration		
Minimum	0.000	Maximum	59.999
Default	0.000	Units	
Type	16 Bit User Save	Update Rate	Background read
Display Format	Standard	Decimal Places	3
Coding	RW, PT, BU		

See *Parameter 00.001 Set-up* (22.001).

Parameter	22.038 Parameter 00.038 Set-up		
Short description	Defines the parameter to be shown in 00.038		
Mode	Regeneration		
Minimum	0.000	Maximum	59.999
Default	4.013	Units	
Type	16 Bit User Save	Update Rate	Background read
Display Format	Standard	Decimal Places	3
Coding	RW, PT, BU		

See *Parameter 00.001 Set-up* (22.001).

Parameter	22.039 Parameter 00.039 Set-up		
Short description	Defines the parameter to be shown in 00.039		
Mode	Regeneration		
Minimum	0.000	Maximum	59.999
Default	4.014	Units	
Type	16 Bit User Save	Update Rate	Background read
Display Format	Standard	Decimal Places	3
Coding	RW, PT, BU		

See *Parameter 00.001 Set-up* (22.001).

Parameter	22.040 Parameter 00.040 Set-up		
Short description	Defines the parameter to be shown in 00.040		
Mode	Regeneration		
Minimum	0.000	Maximum	59.999
Default	0.000	Units	
Type	16 Bit User Save	Update Rate	Background read
Display Format	Standard	Decimal Places	3
Coding	RW, PT, BU		

See *Parameter 00.001 Set-up* (22.001).

Parameter	22.041 Parameter 00.041 Set-up		
Short description	Defines the parameter to be shown in 00.041		
Mode	Regeneration		
Minimum	0.000	Maximum	59.999
Default	5.018	Units	
Type	16 Bit User Save	Update Rate	Background read
Display Format	Standard	Decimal Places	3
Coding	RW, PT, BU		

See *Parameter 00.001 Set-up* (22.001).

Parameter	22.042 Parameter 00.042 Set-up		
Short description	Defines the parameter to be shown in 00.042		
Mode	Regeneration		
Minimum	0.000	Maximum	59.999
Default	0.000	Units	
Type	16 Bit User Save	Update Rate	Background read
Display Format	Standard	Decimal Places	3
Coding	RW, PT, BU		

See *Parameter 00.001 Set-up* (22.001).

Parameter	22.043 Parameter 00.043 Set-up		
Short description	Defines the parameter to be shown in 00.043		
Mode	Regeneration		
Minimum	0.000	Maximum	59.999
Default	0.000	Units	
Type	16 Bit User Save	Update Rate	Background read
Display Format	Standard	Decimal Places	3
Coding	RW, PT, BU		

See *Parameter 00.001 Set-up* (22.001).

Parameter	22.044 Parameter 00.044 Set-up		
Short description	Defines the parameter to be shown in 00.044		
Mode	Regeneration		
Minimum	0.000	Maximum	59.999
Default	0.000	Units	
Type	16 Bit User Save	Update Rate	Background read
Display Format	Standard	Decimal Places	3
Coding	RW, PT, BU		

See *Parameter 00.001 Set-up* (22.001).

Parameter	22.045 Parameter 00.045 Set-up		
Short description	Defines the parameter to be shown in 00.045		
Mode	Regeneration		
Minimum	0.000	Maximum	59.999
Default	4.015	Units	
Type	16 Bit User Save	Update Rate	Background read
Display Format	Standard	Decimal Places	3
Coding	RW, PT, BU		

See *Parameter 00.001 Set-up* (22.001).

Parameter	22.046 Parameter 00.046 Set-up		
Short description	Defines the parameter to be shown in 00.046		
Mode	Regeneration		
Minimum	0.000	Maximum	59.999
Default	5.007	Units	
Type	16 Bit User Save	Update Rate	Background read
Display Format	Standard	Decimal Places	3
Coding	RW, PT, BU		

See *Parameter 00.001 Set-up* (22.001).

Parameter	22.047 Parameter 00.047 Set-up		
Short description	Defines the parameter to be shown in 00.047		
Mode	Regeneration		
Minimum	0.000	Maximum	59.999
Default	0.000	Units	
Type	16 Bit User Save	Update Rate	Background read
Display Format	Standard	Decimal Places	3
Coding	RW, PT, BU		

See *Parameter 00.001 Set-up* (22.001).

Parameter	22.048 Parameter 00.048 Set-up		
Short description	Defines the parameter to be shown in 00.048		
Mode	Regeneration		
Minimum	0.000	Maximum	59.999
Default	11.031	Units	
Type	16 Bit User Save	Update Rate	Background read
Display Format	Standard	Decimal Places	3
Coding	RW, PT, BU		

See *Parameter 00.001 Set-up* (22.001).

Parameter	22.049 Parameter 00.049 Set-up		
Short description	Defines the parameter to be shown in 00.049		
Mode	Regeneration		
Minimum	0.000	Maximum	59.999
Default	11.044	Units	
Type	16 Bit User Save	Update Rate	Background read
Display Format	Standard	Decimal Places	3
Coding	RW, PT, BU		

See *Parameter 00.001 Set-up* (22.001).

Parameter	22.050 Parameter 00.050 Set-up		
Short description	Defines the parameter to be shown in 00.050		
Mode	Regeneration		
Minimum	0.000	Maximum	59.999
Default	11.029	Units	
Type	16 Bit User Save	Update Rate	Background read
Display Format	Standard	Decimal Places	3
Coding	RW, PT, BU		

See *Parameter 00.001 Set-up* (22.001).

Parameter	22.051 Parameter 00.051 Set-up		
Short description	Defines the parameter to be shown in 00.051		
Mode	Regeneration		
Minimum	0.000	Maximum	59.999
Default	10.037	Units	
Type	16 Bit User Save	Update Rate	Background read
Display Format	Standard	Decimal Places	3
Coding	RW, PT, BU		

See *Parameter 00.001 Set-up* (22.001).

Parameter	22.052 Parameter 00.052 Set-up		
Short description	Defines the parameter to be shown in 00.052		
Mode	Regeneration		
Minimum	0.000	Maximum	59.999
Default	0.000	Units	
Type	16 Bit User Save	Update Rate	Background read
Display Format	Standard	Decimal Places	3
Coding	RW, PT, BU		

See *Parameter 00.001 Set-up* (22.001).

Parameter	22.053 Parameter 00.053 Set-up		
Short description	Defines the parameter to be shown in 00.053		
Mode	Regeneration		
Minimum	0.000	Maximum	59.999
Default	0.000	Units	
Type	16 Bit User Save	Update Rate	Background read
Display Format	Standard	Decimal Places	3
Coding	RW, PT, BU		

See *Parameter 00.001 Set-up* (22.001).

Parameter	22.054 Parameter 00.054 Set-up		
Short description	Defines the parameter to be shown in 00.054		
Mode	Regeneration		
Minimum	0.000	Maximum	59.999
Default	0.000	Units	
Type	16 Bit User Save	Update Rate	Background read
Display Format	Standard	Decimal Places	3
Coding	RW, PT, BU		

See *Parameter 00.001 Set-up* (22.001).

Parameter	22.055 Parameter 00.055 Set-up		
Short description	Defines the parameter to be shown in 00.055		
Mode	Regeneration		
Minimum	0.000	Maximum	59.999
Default	0.000	Units	
Type	16 Bit User Save	Update Rate	Background read
Display Format	Standard	Decimal Places	3
Coding	RW, PT, BU		

See *Parameter 00.001 Set-up* (22.001).

Parameter	22.056 Parameter 00.056 Set-up		
Short description	Defines the parameter to be shown in 00.056		
Mode	Regeneration		
Minimum	0.000	Maximum	59.999
Default	0.000	Units	
Type	16 Bit User Save	Update Rate	Background read
Display Format	Standard	Decimal Places	3
Coding	RW, PT, BU		

See *Parameter 00.001 Set-up* (22.001).

Parameter	22.057 Parameter 00.057 Set-up		
Short description	Defines the parameter to be shown in 00.057		
Mode	Regeneration		
Minimum	0.000	Maximum	59.999
Default	0.000	Units	
Type	16 Bit User Save	Update Rate	Background read
Display Format	Standard	Decimal Places	3
Coding	RW, PT, BU		

See *Parameter 00.001 Set-up* (22.001).

Parameter	22.058 Parameter 00.058 Set-up		
Short description	Defines the parameter to be shown in 00.058		
Mode	Regeneration		
Minimum	0.000	Maximum	59.999
Default	0.000	Units	
Type	16 Bit User Save	Update Rate	Background read
Display Format	Standard	Decimal Places	3
Coding	RW, PT, BU		

See *Parameter 00.001 Set-up* (22.001).

Parameter	22.059 Parameter 00.059 Set-up		
Short description	Defines the parameter to be shown in 00.059		
Mode	Regeneration		
Minimum	0.000	Maximum	59.999
Default	0.000	Units	
Type	16 Bit User Save	Update Rate	Background read
Display Format	Standard	Decimal Places	3
Coding	RW, PT, BU		

See *Parameter 00.001 Set-up* (22.001).

Parameter	22.060 Parameter 00.060 Set-up		
Short description	Defines the parameter to be shown in 00.060		
Mode	Regeneration		
Minimum	0.000	Maximum	59.999
Default	0.000	Units	
Type	16 Bit User Save	Update Rate	Background read
Display Format	Standard	Decimal Places	3
Coding	RW, PT, BU		

See *Parameter 00.001 Set-up* (22.001).

Parameter	22.061 Parameter 00.061 Set-up		
Short description	Defines the parameter to be shown in 00.061		
Mode	Regeneration		
Minimum	0.000	Maximum	59.999
Default	0.000	Units	
Type	16 Bit User Save	Update Rate	Background read
Display Format	Standard	Decimal Places	3
Coding	RW, PT, BU		

See *Parameter 00.001 Set-up* (22.001).

Parameter	22.062 Parameter 00.062 Set-up		
Short description	Defines the parameter to be shown in 00.062		
Mode	Regeneration		
Minimum	0.000	Maximum	59.999
Default	0.000	Units	
Type	16 Bit User Save	Update Rate	Background read
Display Format	Standard	Decimal Places	3
Coding	RW, PT, BU		

See *Parameter 00.001 Set-up* (22.001).

Parameter	22.063 Parameter 00.063 Set-up		
Short description	Defines the parameter to be shown in 00.063		
Mode	Regeneration		
Minimum	0.000	Maximum	59.999
Default	0.000	Units	
Type	16 Bit User Save	Update Rate	Background read
Display Format	Standard	Decimal Places	3
Coding	RW, PT, BU		

See *Parameter 00.001 Set-up* (22.001).

Parameter	22.064 Parameter 00.064 Set-up		
Short description	Defines the parameter to be shown in 00.064		
Mode	Regeneration		
Minimum	0.000	Maximum	59.999
Default	0.000	Units	
Type	16 Bit User Save	Update Rate	Background read
Display Format	Standard	Decimal Places	3
Coding	RW, PT, BU		

See *Parameter 00.001 Set-up* (22.001).

Parameter	22.065 Parameter 00.065 Set-up		
Short description	Defines the parameter to be shown in 00.065		
Mode	Regeneration		
Minimum	0.000	Maximum	59.999
Default	0.000	Units	
Type	16 Bit User Save	Update Rate	Background read
Display Format	Standard	Decimal Places	3
Coding	RW, PT, BU		

See *Parameter 00.001 Set-up* (22.001).

Parameter	22.066 Parameter 00.066 Set-up		
Short description	Defines the parameter to be shown in 00.066		
Mode	Regeneration		
Minimum	0.000	Maximum	59.999
Default	0.000	Units	
Type	16 Bit User Save	Update Rate	Background read
Display Format	Standard	Decimal Places	3
Coding	RW, PT, BU		

See *Parameter 00.001 Set-up* (22.001).

Parameter	22.067 Parameter 00.067 Set-up		
Short description	Defines the parameter to be shown in 00.067		
Mode	Regeneration		
Minimum	0.000	Maximum	59.999
Default	0.000	Units	
Type	16 Bit User Save	Update Rate	Background read
Display Format	Standard	Decimal Places	3
Coding	RW, PT, BU		

See *Parameter 00.001 Set-up* (22.001).

Parameter	22.068 Parameter 00.068 Set-up		
Short description	Defines the parameter to be shown in 00.068		
Mode	Regeneration		
Minimum	0.000	Maximum	59.999
Default	0.000	Units	
Type	16 Bit User Save	Update Rate	Background read
Display Format	Standard	Decimal Places	3
Coding	RW, PT, BU		

See *Parameter 00.001 Set-up* (22.001).

Parameter	22.069 Parameter 00.069 Set-up		
Short description	Defines the parameter to be shown in 00.069		
Mode	Regeneration		
Minimum	0.000	Maximum	59.999
Default	0.000	Units	
Type	16 Bit User Save	Update Rate	Background read
Display Format	Standard	Decimal Places	3
Coding	RW, PT, BU		

See *Parameter 00.001 Set-up* (22.001).

Parameter	22.070 Parameter 00.070 Set-up		
Short description	Defines the parameter to be shown in 00.070		
Mode	Regeneration		
Minimum	0.000	Maximum	59.999
Default	0.000	Units	
Type	16 Bit User Save	Update Rate	Background read
Display Format	Standard	Decimal Places	3
Coding	RW, PT, BU		

See *Parameter 00.001 Set-up* (22.001).

Parameter	22.071 Parameter 00.071 Set-up		
Short description	Defines the parameter to be shown in 00.071		
Mode	Regeneration		
Minimum	0.000	Maximum	59.999
Default	0.000	Units	
Type	16 Bit User Save	Update Rate	Background read
Display Format	Standard	Decimal Places	3
Coding	RW, PT, BU		

See *Parameter 00.001 Set-up* (22.001).

Parameter	22.072 Parameter 00.072 Set-up		
Short description	Defines the parameter to be shown in 00.072		
Mode	Regeneration		
Minimum	0.000	Maximum	59.999
Default	0.000	Units	
Type	16 Bit User Save	Update Rate	Background read
Display Format	Standard	Decimal Places	3
Coding	RW, PT, BU		

See *Parameter 00.001 Set-up* (22.001).

Parameter	22.073 Parameter 00.073 Set-up		
Short description	Defines the parameter to be shown in 00.073		
Mode	Regeneration		
Minimum	0.000	Maximum	59.999
Default	0.000	Units	
Type	16 Bit User Save	Update Rate	Background read
Display Format	Standard	Decimal Places	3
Coding	RW, PT, BU		

See *Parameter 00.001 Set-up* (22.001).

Parameter	22.074 Parameter 00.074 Set-up		
Short description	Defines the parameter to be shown in 00.074		
Mode	Regeneration		
Minimum	0.000	Maximum	59.999
Default	0.000	Units	
Type	16 Bit User Save	Update Rate	Background read
Display Format	Standard	Decimal Places	3
Coding	RW, PT, BU		

See *Parameter 00.001 Set-up* (22.001).

Parameter	22.075 Parameter 00.075 Set-up		
Short description	Defines the parameter to be shown in 00.075		
Mode	Regeneration		
Minimum	0.000	Maximum	59.999
Default	0.000	Units	
Type	16 Bit User Save	Update Rate	Background read
Display Format	Standard	Decimal Places	3
Coding	RW, PT, BU		

See *Parameter 00.001 Set-up* (22.001).

Parameter	22.076 Parameter 00.076 Set-up		
Short description	Defines the parameter to be shown in 00.076		
Mode	Regeneration		
Minimum	0.000	Maximum	59.999
Default	0.000	Units	
Type	16 Bit User Save	Update Rate	Background read
Display Format	Standard	Decimal Places	3
Coding	RW, PT, BU		

See *Parameter 00.001 Set-up* (22.001).

Parameter	22.077 Parameter 00.077 Set-up		
Short description	Defines the parameter to be shown in 00.077		
Mode	Regeneration		
Minimum	0.000	Maximum	59.999
Default	0.000	Units	
Type	16 Bit User Save	Update Rate	Background read
Display Format	Standard	Decimal Places	3
Coding	RW, PT, BU		

See *Parameter 00.001 Set-up* (22.001).

Parameter	22.078 Parameter 00.078 Set-up		
Short description	Defines the parameter to be shown in 00.078		
Mode	Regeneration		
Minimum	0.000	Maximum	59.999
Default	0.000	Units	
Type	16 Bit User Save	Update Rate	Background read
Display Format	Standard	Decimal Places	3
Coding	RW, PT, BU		

See *Parameter 00.001 Set-up* (22.001).

Parameter	22.079 Parameter 00.079 Set-up		
Short description	Defines the parameter to be shown in 00.079		
Mode	Regeneration		
Minimum	0.000	Maximum	59.999
Default	0.000	Units	
Type	16 Bit User Save	Update Rate	Background read
Display Format	Standard	Decimal Places	3
Coding	RW, PT, BU		

See *Parameter 00.001 Set-up* (22.001).

Parameter	22.080 Parameter 00.080 Set-up		
Short description	Defines the parameter to be shown in 00.080		
Mode	Regeneration		
Minimum	0.000	Maximum	59.999
Default	0.000	Units	
Type	16 Bit User Save	Update Rate	Background read
Display Format	Standard	Decimal Places	3
Coding	RW, PT, BU		

See *Parameter 00.001 Set-up* (22.001).

Slot 3 Menu 0 Single Line Descriptions – EtherCAT Setup

Mode: Regeneration

Parameter		Range	Default	Type					
3.00.001	Module ID	0 to 65535		RO	Num	ND	NC	PT	
3.00.002	Software Version	0 to 99999999		RO	Num	ND	NC	PT	
3.00.003	Hardware version	0.00 to 655.35		RO	Num	ND	NC	PT	
3.00.004	Serial Number LS	00000000 to 99999999		RO	Num	ND	NC	PT	
3.00.005	Serial Number MS	0 to 99999999		RO	Num	ND	NC	PT	
3.00.006	Status	Bootldr - Update (-2), Bootldr - Idle (-1), Initialising (0), OK (1), Config (2), Error (3)		RO	Txt	ND	NC	PT	
3.00.007	Reset	Off (0) or On (1)	Off (0)	RW	Bit		NC		
3.00.008	Default	Off (0) or On (1)	Off (0)	RW	Bit		NC		
3.00.031	Slot indicator	1 to 8		RO	Num	ND	NC	PT	
3.00.032	Slot menu number	0 to 255		RO	Num	ND	NC	PT	
3.00.033	Disable drive control	Off (0) or On (1)	Off (0)	RW	Bit				US
3.00.034	Allow EEPROM Upgrade	Off (0) or On (1)	Off (0)	RW	Bit				
3.00.035	Configured station alias	0 to 65535	0	RW	Num		NC	PT	US
3.00.036	Consistency trigger for synchronous outputs	Off (0) or On (1)	Off (0)	RW	Bit				US
3.00.037	Consistency trigger parameter for synchronous outputs	0 to 999999	0	RW	Num	DE			US
3.00.038	Consistency trigger for synchronous inputs	Off (0) or On (1)	Off (0)	RW	Bit				US
3.00.039	Consistency trigger parameter for synchronous inputs	0 to 999999	0	RW	Num	DE			US
3.00.040	Consistency trigger for non-synchronous outputs	Off (0) or On (1)	Off (0)	RW	Bit				US
3.00.041	Consistency trigger parameter for non-synchronous outputs	0 to 999999	0	RW	Num	DE			US
3.00.042	Consistency trigger for non-synchronous inputs	Off (0) or On (1)	Off (0)	RW	Bit				US
3.00.043	Consistency trigger parameter for non-synchronous inputs	0 to 999999	0	RW	Num	DE			US
3.00.045	Homing Position Save	Off (0) or On (1)	Off (0)	RW	Bit				PT US
3.00.046	Homing Position Parameter	51 to 54	51	RW	Num				PT US

RW	Read / Write	RO	Read-only	Bit	Bit parameter	Txt	Text string	Date	Date parameter	Time	Time parameter
Chr	Character parameter	Bin	Binary parameter	IP	IP address	Mac	MAC address	Ver	Version number	SMP	Slot, menu, parameter
Num	Number parameter	DE	Destination	ND	No default value	RA	Rating dependent	NC	Non-copyable	PT	Protected
FI	Filtered	US	User save	PS	Power-down save						

Slot 3 Menu 0 – EtherCAT Setup

Mode: Regeneration

This menu provides some common fieldbus option parameters used for basic housekeeping and information.

Parameter	3.00.001 Module ID		
Short description	Module ID		
Minimum	0	Maximum	65535
Default		Units	
Type	16 Bit Volatile	Update Rate	
Display Format	Standard	Decimal Places	0
Coding	RO, ND, NC, PT, BU		

The Module ID. EtherCAT = 435

Parameter	3.00.002 Software Version		
Short description	Software Version		
Minimum	0	Maximum	99999999
Default		Units	
Type	32 Bit Volatile	Update Rate	Power up write
Display Format	Version	Decimal Places	0
Coding	RO, ND, NC, PT		

Module firmware version in ww.xx.yy.zz format

Parameter	3.00.003 Hardware version		
Short description	Hardware version		
Minimum	0.00	Maximum	655.35
Default		Units	
Type	16 Bit Volatile	Update Rate	Power up write
Display Format	Standard	Decimal Places	2
Coding	RO, ND, NC, PT, BU		

Contains the module's hardware version information in the format xx.yy.

Parameter	3.00.004 Serial Number LS		
Short description	Serial Number LS		
Minimum	0 (Display: 00000000)	Maximum	99999999 (Display: 99999999)
Default		Units	
Type	32 Bit Volatile	Update Rate	Power-up write
Display Format	Lead Zero Pad	Decimal Places	0
Coding	RO, ND, NC, PT		

The module serial number is available as a pair of 32 bit values where *Serial Number LS* (MM.004) provides the least significant 8 decimal digits and *Serial Number MS* (MM.005) provides the most significant 8 decimal digits. The reconstructed serial number is ((MM.005* 10000000) + MM.004). For example serial number "0001234567898765" would be stored as MM.005 = 12345, MM.004 = 67898765.

Parameter	3.00.005 Serial Number MS		
Short description	Serial Number MS		
Minimum	0	Maximum	99999999
Default		Units	
Type	32 Bit Volatile	Update Rate	Power-up write
Display Format	Standard	Decimal Places	0
Coding	RO, ND, NC, PT		

See *Serial Number LS* (MM.004).

Parameter	3.00.006 Status		
Short description	Status		
Minimum	-2	Maximum	3
Default		Units	
Type	8 Bit Volatile	Update Rate	Background
Display Format	Standard	Decimal Places	0
Coding	RO, TE, ND, NC, PT		

Value	Text	Description
-2	Bootldr - Update	The bootloader is performing a flash update
-1	Bootldr - Idle	The bootloader is idle
0	Initialising	
1	OK	Module is initialised with no errors present
2	Config	A configuration error has been detected
3	Error	An error has occurred preventing the module from running correctly

Parameter	3.00.007 Reset		
Short description	Reset		
Minimum	0	Maximum	1
Default	0	Units	
Type	1 Bit Volatile	Update Rate	Read every 200ms, Written to 0 on module initialisation
Display Format	Standard	Decimal Places	0
Coding	RW, NC		

When set the module performs a warm reset. When the reset has been performed and the module is performing its initialization routines the parameter will be cleared to zero. Note: The drive, and any other modules fitted to the drive will not be affected by the reset. If motion is currently be performed, and it is possible, the motor will be ramped to a stop before the reset occurs.

Parameter	3.00.008 Default		
Short description	Default		
Minimum	0	Maximum	1
Default	0	Units	
Type	1 Bit Volatile	Update Rate	Read every 200ms, Written to 0 on module initialisation
Display Format	Standard	Decimal Places	0
Coding	RW, NC		

If set to "ON" when the module is reset, this parameter will cause the option module to return to its "Out of Box configuration" any settings stored on the module will be returned to their default values. This will include the CoE object dictionary, if it is saved. Following the default the module will set the parameter to "OFF" and the module will reset.

Take care using this parameter as any configuration information will be irretrievably lost

Parameter	3.00.031 Slot indicator		
Short description	Slot the option is installed in		
Minimum	1	Maximum	8
Default		Units	
Type	8 Bit Volatile	Update Rate	Power-up write
Display Format	Standard	Decimal Places	0
Coding	RO, ND, NC, PT, BU		

The parameter displays the number of the virtual option slot on the drive that the module is connected to. The values for the slots are 1 to 8, where the onboard slot is 4.

Parameter	3.00.032 Slot menu number		
Short description	The menu for the slot		
Minimum	0	Maximum	255
Default		Units	
Type	8 Bit Volatile	Update Rate	Power-up write
Display Format	Standard	Decimal Places	0
Coding	RO, ND, NC, PT, BU		

The parameter displays the menu number of the option slot on the drive.

Depending on the number of slots available, the following mapping applies:

Slot 1 – Menu 15

Slot 2 – Menu 16

Slot 3 – Menu 17

Slot 4 – Menu 24

Parameter	3.00.033 Disable drive control		
Short description	Prevent option from controlling drive.		
Minimum	0	Maximum	1
Default	0	Units	
Type	1 Bit User Save	Update Rate	Background read
Display Format	Standard	Decimal Places	0
Coding	RW		

In normal operation, at various points in EtherCAT and CiA402 operation, a number of drive parameter values will be modified by the option module (other parameters implicitly written by the CiA402 profile, etc).

Setting this parameter to 1 will request that control will be stopped. This will prevent an EtherCAT master from controlling the drive once the control word enable parameter is disabled. If the module is currently in OPERATION_ENABLED it will cause a Fault reaction to take place before the control word enable is disabled.

This parameter must be set back to 0 for normal operation.

Parameter	3.00.034 Allow EEPROM Upgrade		
Short description	Prevent the EtherCAT ASIC from controlling the EEPROM (disabling comms)		
Minimum	0	Maximum	1
Default	0	Units	
Type	1 Bit Volatile	Update Rate	Background read
Display Format	Standard	Decimal Places	0
Coding	RW		

This allows the data in the EtherCAT configuration EEPROM to be upgraded, and it does this by preventing the EtherCAT ASIC from accessing the EEPROM, so that the processor can access it; this means that EtherCAT communications are disabled. This is used by setting this parameter and performing a option reset; the parameter cannot be saved.

Parameter	3.00.035 Configured station alias		
Short description	Configured station alias		
Minimum	0	Maximum	65535
Default	0	Units	
Type	16 Bit User Save	Update Rate	Read on power up or reset
Display Format	Standard	Decimal Places	0
Coding	RW, NC, PT, BU		

It is unnecessary for a user to set a station address manually in order to initiate EtherCAT communications; however, this parameter can be used to configure an EtherCAT Station Alias, which can be used to uniquely identify a particular slave. If this value is changed, it is necessary to reset the option for the new value to take effect (e.g. by saving parameters and performing a power cycle). If this value is left at the default value of zero, any value stored in the EtherCAT EEPROM will be used, and if a non-zero value is stored here, it will be used in place of the EEPROM value.

Parameter	3.00.036 Consistency trigger for synchronous outputs		
Short description	Consistency trigger for synchronous outputs		
Minimum	0	Maximum	1
Default	0	Units	
Type	1 Bit User Save	Update Rate	EtherCAT state transition
Display Format	Standard	Decimal Places	0
Coding	RW		

Parameter	3.00.037 Consistency trigger parameter for synchronous outputs		
Short description	Consistency trigger parameter for synchronous outputs		
Minimum	0	Maximum	999999
Default	0	Units	
Type	32 Bit User Save	Update Rate	EtherCAT state transition
Display Format	Slot Menu Parameter	Decimal Places	0
Coding	RW, DE		

When the output consistency is enabled (in s.00.036 or s.00.040), the configured parameter (in s.00.037 or s.00.041 respectively) is used to control the data exchange, ensuring skew does not occur; a user program, etc, must check the configured parameter is 1 before reading the data received over the EtherCAT network, and it should clear the parameter to 0 after all the data has been read.

The SI-EtherCAT option will check that the parameter is 0 before writing RxPDO destinations and will set the parameter to 1 after the RxPDO destinations have been written.

Parameter	3.00.038 Consistency trigger for synchronous inputs		
Short description	Consistency trigger for synchronous inputs		
Minimum	0	Maximum	1
Default	0	Units	
Type	1 Bit User Save	Update Rate	EtherCAT state transition
Display Format	Standard	Decimal Places	0
Coding	RW		

Parameter	3.00.039 Consistency trigger parameter for synchronous inputs		
Short description	Consistency trigger parameter for synchronous inputs		
Minimum	0	Maximum	999999
Default	0	Units	
Type	32 Bit User Save	Update Rate	EtherCAT state transition
Display Format	Slot Menu Parameter	Decimal Places	0
Coding	RW, DE		

When the input consistency is enabled (in s.00.038 or s.00.042), the configured parameter (in s.00.039 or s.00.043 respectively) is used to control the data exchange, ensuring skew does not occur; a user program, etc, must check the configured parameter is 0 before writing the data to be transmitted over the EtherCAT network, and it should set the parameter to 1 after all the data has been written.

The SI-EtherCAT option will check that the parameter is 1 before reading TxPDO sources and will set the parameter to 0 after the TxPDO sources have been read.

Parameter	3.00.040 Consistency trigger for non-synchronous outputs		
Short description	Consistency trigger for non-synchronous outputs		
Minimum	0	Maximum	1
Default	0	Units	
Type	1 Bit User Save	Update Rate	EtherCAT state transition
Display Format	Standard	Decimal Places	0
Coding	RW		

Parameter	3.00.041 Consistency trigger parameter for non-synchronous outputs		
Short description	Consistency trigger parameter for non-synchronous outputs		
Minimum	0	Maximum	999999
Default	0	Units	
Type	32 Bit User Save	Update Rate	EtherCAT state transition
Display Format	Slot Menu Parameter	Decimal Places	0
Coding	RW, DE		

See the description of parameter s.00.037.

Parameter	3.00.042 Consistency trigger for non-synchronous inputs		
Short description	Consistency trigger for non-synchronous inputs		
Minimum	0	Maximum	1
Default	0	Units	
Type	1 Bit User Save	Update Rate	EtherCAT state transition
Display Format	Standard	Decimal Places	0
Coding	RW		

Parameter	3.00.043 Consistency trigger parameter for non-synchronous inputs		
Short description	Consistency trigger parameter for non-synchronous inputs		
Minimum	0	Maximum	999999
Default	0	Units	
Type	32 Bit User Save	Update Rate	EtherCAT state transition
Display Format	Slot Menu Parameter	Decimal Places	0
Coding	RW, DE		

See the description of parameter s.00.039.

Parameter	3.00.045 Homing Position Save		
Short description	Enable homing position user save		
Minimum	0	Maximum	1
Default	0	Units	
Type	1 Bit User Save	Update Rate	Background
Display Format	Standard	Decimal Places	0
Coding	RW, PT		

Used to control if Homing Position is saved and used at start-up

Parameter	3.00.046 Homing Position Parameter		
Short description	Menu 18 user save parameter selection		
Minimum	51	Maximum	54
Default	51	Units	
Type	8 Bit User Save	Update Rate	Background
Display Format	Standard	Decimal Places	0
Coding	RW, PT		

This parameter is used to define the parameter in menu 18. This is limited to the 32bit User save parameters. The defined parameter will be updated at the end of homing and then read on initiation as the Homing Position if HOMING_POSITION_SAVE is set to true.

Slot 3 Menu 1 Single Line Descriptions – Status and Configuration

Mode: Regeneration

Parameter		Range	Default	Type					
3.01.001	EtherCAT run indicator	Unknown State (0), Init (1), PreOp (2), Unknown State (3), SafeOp (4), Unknown State (5), SafeOp to Op (6), Unknown State (7), Op (8)		RO	Txt	ND	NC	PT	
3.01.002	PDO Accesses per second	0 to 65535		RO	Num	ND	NC	PT	
3.01.004	Mapped parameter xx.000	0 to 65535		RW	Num	ND	NC	PT	

RW	Read / Write	RO	Read-only	Bit	Bit parameter	Txt	Text string	Date	Date parameter	Time	Time parameter
Chr	Character parameter	Bin	Binary parameter	IP	IP address	Mac	MAC address	Ver	Version number	SMP	Slot, menu, parameter
Num	Number parameter	DE	Destination	ND	No default value	RA	Rating dependent	NC	Non-copyable	PT	Protected
FI	Filtered	US	User save	PS	Power-down save						

Slot 3 Menu 1 – Status and Configuration

Mode: Regeneration

Parameter	3.01.001 EtherCAT run indicator		
Short description	EtherCAT run indicator		
Minimum	0	Maximum	8
Default		Units	
Type	8 Bit Volatile	Update Rate	Background
Display Format	Standard	Decimal Places	0
Coding	RO, TE, ND, NC, PT, BU		

Value	Text	Description
0	Unknown State	Unknown State Value
1	Init	Initial
2	PreOp	Pre Operational
3	Unknown State	Unknown State Value
4	SafeOp	Safe Operational
5	Unknown State	Unknown State Value
6	SafeOp to Op	SafeOp to Op
7	Unknown State	Unknown State Value
8	Op	Operational

This parameter displays the EtherCAT Run state, as required by the EtherCAT Indicator and Marking Specification.

Parameter	3.01.002 PDO Accesses per second		
Short description	PDO Accesses per second		
Minimum	0	Maximum	65535
Default		Units	
Type	16 Bit Volatile	Update Rate	Background
Display Format	Standard	Decimal Places	0
Coding	RO, ND, NC, PT, BU		

This will count the number of PDO accesses per second. For example, if there are two PDOs configured in Sync Manager 2, and two PDOs configured in Sync Manager 3, and both Sync Manager memory areas are written every 250µs, this parameter will contain a value of approximately 16000 (the value may fluctuate slightly because it is not updated synchronously with the accesses).

Parameter	3.01.004 Mapped parameter xx.000		
Short description	Mapped parameter xx.000		
Minimum	0	Maximum	65535
Default		Units	
Type	16 Bit Volatile	Update Rate	By EtherCAT PDO or SDO
Display Format	Standard	Decimal Places	0
Coding	RW, ND, NC, PT, BU		

This parameter is purely a mapping to parameter xx.000, to allow this parameter to be accessed using a CoE object (mapped CoE object indices correspond to menu numbers, and sub-object indices correspond to parameter numbers; since sub-object index zero is already used for another CoE purpose, it cannot be used to access parameter zero of a menu).

Slot 3 Menu 2 Single Line Descriptions – EoE Status

Mode: Regeneration

Parameter		Range	Default	Type					
3.02.003	EoE Status	Initialising (0), Link Down (1), Not Applicable (2), Not Applicable (3), Ready (4), Active (5), Active With Errs (6)		RO	Txt	ND	NC	PT	
3.02.004	EoE Network Message Count	0.0 to 6553.5 Messages/s		RO	Num	ND	NC	PT	
3.02.006	EoE IP Address	0.0.0.0 to 255.255.255.255		RO	IP	ND	NC	PT	
3.02.007	EoE Subnet Mask	0.0.0.0 to 255.255.255.255		RO	IP	ND	NC	PT	
3.02.008	EoE Default Gateway	0.0.0.0 to 255.255.255.255		RO	IP	ND	NC	PT	
3.02.011	EoE Virtual MAC Address	00:00:00:00:00:00 to FF:FF:FF:FF:FF:FF		RO	Mac	ND	NC	PT	

RW	Read / Write	RO	Read-only	Bit	Bit parameter	Txt	Text string	Date	Date parameter	Time	Time parameter
Chr	Character parameter	Bin	Binary parameter	IP	IP address	Mac	MAC address	Ver	Version number	SMP	Slot, menu, parameter
Num	Number parameter	DE	Destination	ND	No default value	RA	Rating dependent	NC	Non-copyable	PT	Protected
Fl	Filtered	US	User save	PS	Power-down save						

Slot 3 Menu 2 – EoE Status

Mode: Regeneration

Ethernet over EtherCAT (EoE) Status.

Parameter	3.02.003 EoE Status		
Short description	Status of EoE		
Minimum	0	Maximum	6
Default		Units	
Type	8 Bit Volatile	Update Rate	Background Write
Display Format	Standard	Decimal Places	0
Coding	RO, TE, ND, NC, PT, BU		

Value	Text	Description
0	Initialising	The EoE interface is being initialised
1	Link Down	No EoE connection has been detected
2	Not Applicable	
3	Not Applicable	
4	Ready	The EoE interface has been successfully configured but no data is being received or transmitted
5	Active	The EoE interface is receiving or transmitting data
6	Active With Errs	The EoE interface is receiving or transmitting data but Receive errors have been detected

This is the status of the EoE interface

Parameter	3.02.004 EoE Network Message Count		
Short description	EoE Network Message Count		
Minimum	0.0	Maximum	6553.5
Default		Units	Messages/s
Type	16 Bit Volatile	Update Rate	Background Write
Display Format	Standard	Decimal Places	1
Coding	RO, ND, NC, PT, BU		

This is the Average number of Ethernet frames received and transmitted via EoE

Parameter	3.02.006 EoE IP Address		
Short description	Shows the IP address of the module set by EoE		
Minimum	0 (Display: 0.0.0.0)	Maximum	4294967295 (Display: 255.255.255.255)
Default		Units	
Type	32 Bit Volatile	Update Rate	On EtherCAT initialisation
Display Format	IP Address	Decimal Places	0
Coding	RO, ND, NC, PT, BU		

Displays the IP address of the module, as set by Ethernet over EtherCAT (EoE).

Parameter	3.02.007 EoE Subnet Mask		
Short description	Shows the subnet mask of the module		
Minimum	0 (Display: 0.0.0.0)	Maximum	4294967295 (Display: 255.255.255.255)
Default		Units	
Type	32 Bit Volatile	Update Rate	On EtherCAT initialisation.
Display Format	IP Address	Decimal Places	0
Coding	RO, ND, NC, PT, BU		

Displays the subnet mask of the module, as set by EoE.

Parameter	3.02.008 EoE Default Gateway		
Short description	Shows the default gateway of the module		
Minimum	0 (Display: 0.0.0.0)	Maximum	4294967295 (Display: 255.255.255.255)
Default		Units	
Type	32 Bit Volatile	Update Rate	
Display Format	IP Address	Decimal Places	0
Coding	RO, ND, NC, PT, BU		

Displays the default gateway of the module, as set by EoE.

Parameter	3.02.011 EoE Virtual MAC Address		
Short description	Shows the virtual MAC address of the module (as set by EoE)		
Minimum	0 (Display: 00:00:00:00:00:00)	Maximum	281474976710655 (Display: FF:FF:FF:FF:FF:FF)
Default		Units	
Type	64 Bit Volatile	Update Rate	On EtherCAT initialisation
Display Format	MAC Address	Decimal Places	0
Coding	RO, ND, NC, PT, BU		

Displays the MAC address for the EoE virtual Ethernet interface as a 48 bit hexadecimal value. For example "0A1C0034AB0C".

Slot 3 Menu 9 Single Line Descriptions – Resources

Mode: Regeneration

Parameter		Range	Default	Type					
3.09.010	PreCritical Task % Free	0 to 100 %		RO	Num	ND	NC	PT	
3.09.011	Critical Task % Free	0 to 100 %		RO	Num	ND	NC	PT	
3.09.012	PostCritical Task % Free	0 to 100 %		RO	Num	ND	NC	PT	
3.09.020	PreCritical Task Worst % Free	0 to 100 %		RO	Num	ND	NC	PT	
3.09.021	Critical Task Worst % Free	0 to 100 %		RO	Num	ND	NC	PT	
3.09.022	PostCritical Task Worst % Free	0 to 100 %		RO	Num	ND	NC	PT	
3.09.023	OutData Position %	0 to 100 %		RO	Num	ND	NC	PT	
3.09.030	PCB Temperature	-128 to 127 °C		RO	Num	ND	NC		

RW	Read / Write	RO	Read-only	Bit	Bit parameter	Txt	Text string	Date	Date parameter	Time	Time parameter
Chr	Character parameter	Bin	Binary parameter	IP	IP address	Mac	MAC address	Ver	Version number	SMP	Slot, menu, parameter
Num	Number parameter	DE	Destination	ND	No default value	RA	Rating dependent	NC	Non-copyable	PT	Protected
Fl	Filtered	US	User save	PS	Power-down save						

Slot 3 Menu 9 – Resources

Mode: Regeneration

Parameter	3.09.010 PreCritical Task % Free		
Short description			
Minimum	0	Maximum	100
Default		Units	%
Type	8 Bit Volatile	Update Rate	Background write
Display Format	Standard	Decimal Places	0
Coding	RO, ND, NC, PT, BU		

Current resource available for the PreCritical task. In the SI-EtherCAT option, this is the PreCritical Task executed 75µs before OptSync, the 250µs task executed synchronously with the drive control loops.

Parameter	3.09.011 Critical Task % Free		
Short description			
Minimum	0	Maximum	100
Default		Units	%
Type	8 Bit Volatile	Update Rate	Background write
Display Format	Standard	Decimal Places	0
Coding	RO, ND, NC, PT, BU		

Current resource available for the Critical task. In the SI-EtherCAT option, this is the Critical Task executed on OptSync, every 250µs, executed synchronously with the drive control loops.

Parameter	3.09.012 PostCritical Task % Free		
Short description			
Minimum	0	Maximum	100
Default		Units	%
Type	8 Bit Volatile	Update Rate	Background write
Display Format	Standard	Decimal Places	0
Coding	RO, ND, NC, PT, BU		

Current resource available for the PostCritical task. In the SI-EtherCAT option, this is the PostCritical Task executed 75µs after OptSync, the 250µs task executed synchronously with the drive control loops.

Parameter	3.09.020 PreCritical Task Worst % Free		
Short description			
Minimum	0	Maximum	100
Default		Units	%
Type	8 Bit Volatile	Update Rate	Background write
Display Format	Standard	Decimal Places	0
Coding	RO, ND, NC, PT, BU		

Worst case free resource of the PreCritical task.

Parameter	3.09.021 Critical Task Worst % Free		
Short description			
Minimum	0	Maximum	100
Default		Units	%
Type	8 Bit Volatile	Update Rate	Background write
Display Format	Standard	Decimal Places	0
Coding	RO, ND, NC, PT, BU		

Worst case free resource of the Critical task.

Parameter	3.09.022 PostCritical Task Worst % Free		
Short description			
Minimum	0	Maximum	100
Default		Units	%
Type	8 Bit Volatile	Update Rate	Background write
Display Format	Standard	Decimal Places	0
Coding	RO, ND, NC, PT, BU		

Worst case free resource of the PostCritical task.

Parameter	3.09.023 <i>OutData Position %</i>		
Short description			
Minimum	0	Maximum	100
Default		Units	%
Type	8 Bit Volatile	Update Rate	Background write
Display Format	Standard	Decimal Places	0
Coding	RO, ND, NC, PT, BU		

The position where OutData was read with respect to Sync0, shows as percentage.

Parameter	3.09.030 <i>PCB Temperature</i>		
Short description			
Minimum	-128	Maximum	127
Default		Units	°C
Type	8 Bit Volatile	Update Rate	Background write
Display Format	Standard	Decimal Places	0
Coding	RO, ND, NC		

Module temperature in degrees Celsius

Trips

Mode: Regeneration

Trip 0 (10.020) to *Trip 9* (10.029) store the most recent 10 trips that have occurred where *Trip 0* (10.020) is the most recent and *Trip 9* (10.029) is the oldest. When a new trip occurs it is written to *Trip 0* (10.020) and all the other trips move down the log, with oldest being lost. The date and time when each trip occurs are also stored in the date and time log, i.e. *Trip 0 Date* (10.041) to *Trip 9 Time* (10.060). The date and time are taken from *Date* (06.016) and *Time* (06.017). Some trips have sub-trip numbers which give more detail about the reason for the trip. If a trip has a sub-trip number its value is stored in the sub-trip log, i.e. *Trip 0 Sub-trip Number* (10.070) to *Trip 9 Sub-trip Number* (10.079). If the trip does not have a sub-trip number then zero is stored in the sub-trip log.

Trip categories and priorities

Trips are grouped into the categories given in the table below. A trip can only occur when the drive is not tripped, or if it is already tripped and the new trip has a higher priority than the active trip (i.e. lower priority number). Unless otherwise stated a trip cannot be reset until 1.0s after it has been initiated.

Priority	Category	Trips	Comments
1	Internal faults	<i>HF01</i> – <i>HF20</i>	These are fatal problems that cannot be reset. All drive features are inactive after any of these trips occur. If a basic keypad is fitted it will show the trip, but the keypad will not function. These trips are not stored in the trip log.
1	Stored HF trip	<i>Stored HF</i>	This trip cannot be cleared unless 1299 is entered into <i>Parameter mm.000</i> (mm.000) and a reset is initiated.
2	Non-resettable trips	Trip numbers 218 to 247, <i>Slot1 HF</i> , <i>Slot2 HF</i> , <i>Slot3 HF</i> or <i>Slot4 HF</i>	These trips cannot be reset.
3	Volatile memory failure	<i>EEPROM Fail</i>	This can only be reset if <i>Parameter mm.000</i> (mm.000) is set to 1233 or 1244, or if <i>Load Defaults</i> (11.043) is set to a non-zero value.
4	Internal 24V power supply	<i>PSU 24V</i>	
5	Non-volatile media trips	Trip numbers 174, 175 and 177 to 188	These trips are priority 6 during power-up.
5	Position feedback interface power supply	<i>Encoder 1</i>	This trip can override <i>Encoder 2</i> to <i>Encoder 6</i> trips.
6	Trips with extended reset times	<i>OI ac</i> , <i>OI Brake</i> , and <i>OI dc</i>	These trips cannot be reset until 10s after the trip was initiated.
6	Phase loss and d.c. link power circuit protection	<i>Phase Loss</i> and <i>OHT dc bus</i>	The drive will attempt to stop the motor before tripping if a <i>Phase Loss.000</i> trip occurs unless this feature has been disabled (see <i>Action On Trip Detection</i> (10.037)). The drive will always attempt to stop the motor before tripping if an <i>OHT dc bus</i> occurs.
6	Standard trips	All other trips	

Internal faults

Trips {*HF01*} to {*HF20*} are internal faults that do not have trip numbers. If one of these trips occurs, the main drive processor has detected an irrecoverable error. All drive functions are stopped and the trip message will be displayed on the drive keypad. The error can only be reset by powering the drive down and up again. The table below gives the reasons for internal faults and their corresponding trip.

Trip	Reason
{HF01}	CPU has detected an address error
{HF02}	CPU DMAC has detected an address error
{HF03}	CPU has detected an Illegal opcode
{HF04}	CPU has detected an Illegal slot instruction
{HF05}	An interrupt has occurred that does not have a defined function (Undefined exception)
{HF06}	An interrupt has occurred which is reserved (Reserved exception)
{HF07}	Watchdog failure
{HF08}	CPU Interrupt crash
{HF09}	Free store overflow
{HF10}	Parameter routing system error
{HF11}	Non-volatile memory comms error
{HF12}	Stack overflow. Sub-trip is shown to indicate which stack: 1 – background tasks 2 – timed tasks 3 – main system interrupts
{HF13}	The control hardware is not compatible with the firmware. The sub-trip number gives the actual ID code of the control board hardware.
{HF14}	CPU register bank error
{HF15}	CPU divide error
{HF16}	RTOS error (the background task has returned)
{HF17}	The clock supplied to the control board logic is out of specification
{HF18}	The internal flash memory has failed when writing option module parameter data. Sub-trip is shown to indicate which failure: 1 - Programming error while writing menu in flash 2 - Erase flash block containing setup menus failed 3 - Erase flash block containing application menus failed
{HF19}	Invalid main application firmware CRC. Reprogramming required.
{HF20}	The ASIC is not compatible with the firmware. The sub-trip number displayed is the ASIC version.
{HF23}	If this trip occurs please consult the drive supplier.
{HF24}	If this trip occurs please consult the drive supplier.
{HF25}	If this trip occurs please consult the drive supplier.

When the drive is subsequently powered up a *Stored HF* trip is initiated where the sub-trip number is the number of the HF trip that last occurred. This trip will occur at every power-up until it is reset. The trip can only be reset by first entering 1299 into *Parameter mm.000* (mm.000). If the drive is powered up and a *Stored HF* trip occurs, *Onboard User Program: Enable* (11.047) is reset to zero to prevent the on-board user program from running. This ensures that the user program can be changed or erased in case it causes an HF trip at every power-up. Once the *Stored HF* is cleared, it is necessary to power cycle the drive or to re-download the user program to allow the program to restart.

Similar trips that can be initiated by the control system or the power system

Trips shown in the table below can be generated either from the drive control system or from the power system. The sub-trip number which is in the form *xyzz* is used to identify the source of the trip. The digits *xx* are 00 for a trip generated by the control system or the number of a power module if generated by the power system. If the drive is not a multi-power module drive then *xx* will always have a value of 1 the trip is related to the power system. The *y* digit is used to identify the location of a trip which is generated by a rectifier module connected to a power module. Where the *y* digit is relevant it will have a value of 1 or more, otherwise it will be 0. The *zz* digits give the reason for the trip and are defined in each trip description.

Over Volts	Oht dc bus
OI ac	Phase Loss
OI Brake	Power Comms
PSU	OI Snubber
Oht Inverter	Cloning
Oht Power	Temp Feedback
Oht Control	Power Data

Braking IGBT

The list below gives conditions that will disable the braking IGBT:

1. *Braking IGBT Upper Threshold* (06.074) = 0, or *Low Voltage Braking IGBT Threshold Select* (06.076) = 1 and *Low Voltage Braking IGBT Threshold* (06.075) = 0.
2. The drive is in the under-voltage state.
3. A priority 1, 2 or 3 trip is active (see *Trip 0* (10.020)).
4. One of the following trips is active or would be active if another trip is not already active: *OI Brake*, *PSU*, *Th Brake Res* or *Oht Inverter*.
5. *Percentage Of Drive Thermal Trip Level* (07.036) = 100%. This is an indication that some part of the drive is too hot and is used to indicate if an internally fitted braking resistor is too hot.
6. *Brake R Too Hot* is active or the system has been set up to disable the braking IGBT based on the braking resistor temperature and the resistor is too hot (i.e. bit 2 of *Action On Trip Detection* (10.037) is set).

Note that the braking IGBT over-current trip cannot be reset until 10s after it is initiated. This period consists of a 9s period after the trip where the braking IGBT cannot be switched on again and the *OI Brake* trip is held active and cannot be reset. This 9s period is followed by the normal 1s delay, that is present for other trips, before the trip can be reset. During this 1s period it is possible for the braking IGBT to switch on again. If the conditions

are still present that caused the trip then the trip will be initiated again with a further 9s hold-off period etc.

Trips Summary (numerical order)

Value	Trip
0	None
1	Reserved 001
2	Over Volts
3	OI ac
4	OI Brake
5	PSU
6	External Trip
7	Over Speed
8	Inductance
9	PSU 24V
10	Th Brake Res
11	Autotune 1
12	Autotune 2
13	Autotune 3
14	Autotune 4
15	Autotune 5
16	Autotune 6
17	Autotune 7
18	Autotune Stopped
19	Brake R Too Hot
20	Motor Too Hot
21	OHT Inverter
22	OHT Power
23	OHT Control
24	Thermistor
25	Th Short Circuit
26	I/O Overload
27	OHT dc bus
28	An Input 1 Loss
29	An Input 2 Loss
30	Watchdog
31	EEPROM Fail
32	Phase Loss
33	Resistance
34	Keypad Mode
35	Control Word
36	User Save
37	Power Down Save
38	Low Load
39	Line Sync
40	User Trip 40
41	User Trip 41
42	User Trip 42
43	User Trip 43
44	User Trip 44
45	User Trip 45
46	User Trip 46
47	User Trip 47
48	User Trip 48
49	User Trip 49
50	User Trip 50
51	User Trip 51
52	User Trip 52
53	User Trip 53
54	User Trip 54
55	User Trip 55
56	User Trip 56
57	User Trip 57
58	User Trip 58
59	User Trip 59
60	User Trip 60
61	User Trip 61
62	User Trip 62

63	User Trip 63
64	User Trip 64
65	User Trip 65
66	User Trip 66
67	User Trip 67
68	User Trip 68
69	User Trip 69
70	User Trip 70
71	User Trip 71
72	User Trip 72
73	User Trip 73
74	User Trip 74
75	User Trip 75
76	User Trip 76
77	User Trip 77
78	User Trip 78
79	User Trip 79
80	User Trip 80
81	User Trip 81
82	User Trip 82
83	User Trip 83
84	User Trip 84
85	User Trip 85
86	User Trip 86
87	User Trip 87
88	User Trip 88
89	User Trip 89
90	Power Comms
91	User 24V
92	OI Snubber
93	Inductor Too Hot
94	Rectifier Set-up
95	Reserved 095
96	User Prog Trip
97	Data Changing
98	Out Phase Loss
99	CAM
100	Reset
101	OHT Brake
102	Cloning
103	Inter-connect
104	Reserved 104
105	Reserved 105
106	Reserved 106
107	Reserved 107
108	Reserved 108
109	OI dc
110	Undefined
111	Configuration
112	User Trip 112
113	User Trip 113
114	User Trip 114
115	User Trip 115
116	User Trip 116
117	User Trip 117
118	User Trip 118
119	User Trip 119
120	User Trip 120
121	User Trip 121
122	User Trip 122
123	User Trip 123
124	User Trip 124
125	User Trip 125
126	User Trip 126
127	User Trip 127

128	User Trip 128
129	User Trip 129
130	User Trip 130
131	User Trip 131
132	User Trip 132
133	User Trip 133
134	User Trip 134
135	User Trip 135
136	User Trip 136
137	User Trip 137
138	User Trip 138
139	User Trip 139
140	User Trip 140
141	User Trip 141
142	User Trip 142
143	User Trip 143
144	User Trip 144
145	User Trip 145
146	User Trip 146
147	User Trip 147
148	User Trip 148
149	User Trip 149
150	User Trip 150
151	User Trip 151
152	User Trip 152
153	User Trip 153
154	User Trip 154
155	User Trip 155
156	User Trip 156
157	User Trip 157
158	User Trip 158
159	User Trip 159
160	Island
161	Reserved 161
162	Encoder 12
163	Encoder 13
164	Encoder 14
165	Reserved 165
166	Reserved 166
167	Reserved 167
168	Reserved 168
169	Voltage Range
171	Reserved 171
172	Reserved 172
173	Reserved 173
174	Card Slot
175	Card Product
176	Name Plate
177	Card Boot
178	Card Busy
179	Card Data Exists
180	Card Option
181	Card Read Only
182	Card Error
183	Card No Data
184	Card Full
185	Card Access
186	Card Rating
187	Card Drive Mode
188	Card Compare
189	Encoder 1
190	Encoder 2
191	Encoder 3
192	Encoder 4
193	Encoder 5

194	Encoder 6
195	Encoder 7
196	Encoder 8
197	Encoder 9
199	Destination
200	Slot1 HF
201	Slot1 Watchdog
202	Slot1 Error
203	Slot1 Not Fitted
204	Slot1 Different
205	Slot2 HF
206	Slot2 Watchdog
207	Slot2 Error
208	Slot2 Not Fitted
209	Slot2 Different
210	Slot3 HF
211	Slot3 Watchdog
212	Slot3 Error
213	Slot3 Not Fitted
214	Slot3 Different
215	Option Disable
216	Slot App Menu
217	App Menu Changed
218	Temp Feedback
219	An Output Calib
220	Power Data
221	Stored HF
222	Reserved 222
223	Rating Mismatch
224	Drive Size
225	Current Offset
226	Soft Start
227	Sub-array RAM
228	Reserved 228
229	Reserved 229
230	Reserved 230
231	Reserved 231
232	Reserved 232
233	Reserved 233
234	Reserved 234
235	Reserved 235
236	Reserved 236
237	Reserved 237
238	Reserved 238
239	Reserved 239
240	Reserved 240
241	Reserved 241
242	Reserved 242
243	Reserved 243
244	Reserved 244
245	Reserved 245
246	Reserved 246
247	Derivative ID
248	Derivative Image
249	User Program
250	Slot4 HF
251	Slot4 Watchdog
252	Slot4 Error
253	Slot4 Not Fitted
254	Slot4 Different
255	Reset Logs

Trips (alphabetical order)

Trip	An Input 1 Loss
Value	28
Short description	

Indicates that a current loss was detected in current mode on Analog Input 1 (Terminal 5, 6). In 4-20mA and 20-4mA modes. loss of input is detected if the current falls below 3mA. See *Analog Input 1 Mode* (07.007) for further details.

Recommended actions:

- Check control wiring is correct.
- Check control wiring is undamaged.
- Check *Analog Input 1 Mode* (07.007).
- Check that the current signal is present and greater than 3mA.

Trip	An Input 2 Loss
Value	29
Short description	

Indicates that a current loss was detected in current mode on Analog Input 2 (Terminal 7). In 4-20mA and 20-4mA modes. loss of input is detected if the current falls below 3mA. See *Analog Input 2 Mode* (07.011) for further details.

Recommended actions:

- Check control wiring is correct.
- Check control wiring is undamaged.
- Check *Analog Input 2 Mode* (07.011).
- Check that the current signal is present and greater than 3mA.

Trip	An Output Calib
Value	219
Short description	

The zero offset calibration of one or both of the analogue outputs has failed. This indicates that the drive hardware has failed, or a voltage has been applied to the output via a low impedance possibly due to a wiring error.

Sub-trip	Reason
1	Output 1 failed
2	Output 2 failed

Recommended actions:

- Check the wiring associated with analog outputs.
- Remove all the wiring that is connected to analog outputs and perform a recalibration by power cycling the drive.
- If trip persists, replace the drive.

Trip	App Menu Changed
Value	217
Short description	

The customisation table for an application menu has been changed. The sub-trip indicates which menu has changed:

Sub-trip	Reason
1	Menu 18
2	Menu 19
3	Menu 20

If more than one menu has changed the lowest menu has priority. Drive user parameters must be saved to prevent this trip on the next power-up.

Recommended actions:

- Reset the trip and perform a parameter save to accept the new settings.

Trip	Autotune 1
Value	11
Short description	

The drive has tripped during an auto-tune. The cause of the trip can be identified from the sub-trip number.

Sub-trip	Reason	Recommended actions
1	The position feedback did not change when position feedback is being used during rotating auto-tune.	Ensure that the motor is free to turn (i.e. mechanical brake is released). Check that the position feedback is selected correctly and operates correctly.
2	The motor did not reach the required speed during mechanical load measurement.	Ensure that the motor is free to turn and that the static load plus inertia is not too large for the drive to accelerate within the test time.
3	The required commutation signal edge could not be found during a rotating auto-tune with a Commutation Only position feedback device.	Check that the position feedback signals are connected correctly.
4	The required movement angle cannot be produced during a minimal movement test.	Reduce the angular movement required.
5	The second part of the minimal movement test during auto-tuning cannot locate the motor flux position accurately.	Reduce the angular movement required.
6	The phasing offset angle is measured twice during a stationary auto-tune and the results are not within 30° of each other.	If a minimal movement test is being used and excessive motor movement is occurring during the test reduce the required angle movement. Otherwise try and increase the required angle movement.
7	The motor is moving when a phasing test on enable is selected and the drive is enabled, but the motor is still moving at a speed above the zero speed threshold.	Ensure that the motor is stationary before the drive is enabled.

Trip	Autotune 2
Value	12
Short description	

The drive has tripped during a rotating auto-tune. The cause of the trip can be identified from the associated sub-trip number.

Sub-trip	Reason
1	The position feedback direction is incorrect when position feedback is being used during a rotating auto-tune.
2	A SINCOS encoder with comms is being used for position feedback and the comms position is rotating in the opposite direction to the sine wave based position.

Recommended actions:

- Check motor cable wiring is correct.
- Check feedback device wiring is correct.
- Swap any two motor phases.

Trip	Autotune 3
Value	13
Short description	

The drive has tripped during a rotating auto-tune or mechanical load measurement. The cause of the trip can be identified from the associated sub-trip number.

Sub-trip	Reason
1	Measured inertia has exceeded the parameter range during a mechanical load measurement.
2	The commutation signals changed in the wrong direction during a rotating auto-tune.
3	The mechanical load test has been unable to identify the motor inertia.

Recommended actions for sub-trip 2:

- Check motor cable wiring is correct.
- Check feedback device U, V and W commutation signal wiring is correct.

Recommended actions for sub-trip 3:

- Increase the test level.
- If the test was carried out at standstill repeat the test with the motor rotating within the recommended speed range.

Trip	Autotune 4
Value	14
Short description	

A position feedback device with commutation signals is being used (i.e AB Servo, FD Servo, FR Servo, SC Servo or Commutation Only encoder) and the U commutation signal did not change during a rotating auto-tune.

Recommended actions:

- Check feedback device U commutation signal wiring is correct (Encoder terminals 7 and 8).

Trip	Autotune 5
Value	15
Short description	

A position feedback device with commutation signals is being used (i.e AB Servo, FD Servo, FR Servo, SC Servo or Commutation Only encoder) and the V commutation signal did not change during a rotating auto-tune.

Recommended actions:

- Check feedback device V commutation signal wiring is correct (Encoder terminals 9 and 10).

Trip	Autotune 6
Value	16
Short description	

A position feedback device with commutation signals is being used (i.e AB Servo, FD Servo, FR Servo, SC Servo or Commutation Only encoder) and the W commutation signal did not change during a rotating auto-tune.

Recommended actions:

- Check feedback device W commutation signal wiring is correct (Encoder terminals 11 and 12).

Trip	Autotune 7
Value	17
Short description	

An *Autotune 7* trip is initiated during a rotating auto-tune, if the number of motor poles or the position feedback resolution have been set up incorrectly where position feedback is being used.

Recommended actions:

- Check the lines per revolution for the feedback device.
- Check the number of poles in *Number Of Motor Poles* (05.011).

Trip	Autotune Stopped
Value	18
Short description	

The drive was prevented from completing an auto-tune, because either the Final drive enable or the Final drive run were removed.

Recommended actions:

- Check the drive enable signal (Terminal 31) was active during the auto-tune.
- Check the run command was active in *Digital Input 05 State* (08.005) during the auto-tune.

Trip	Brake R Too Hot
Value	19
Short description	

This trip indicates that braking resistor overload has timed out. The value in *Braking Resistor Thermal Accumulator* (10.039) is calculated using *Braking Resistor Rated Power* (10.030), *Braking Resistor Thermal Time Constant* (10.031) and *Braking Resistor Resistance* (10.061). This trip is initiated when *Braking Resistor Thermal Accumulator* (10.039) reaches 100%.

Recommended actions:

- Ensure the values entered in *Braking Resistor Rated Power* (10.030), *Braking Resistor Thermal Time Constant* (10.031) and *Braking Resistor Resistance* (10.061) are correct.
- If an external thermal protection device is being used and the braking resistor software overload protection is not required, set *Braking Resistor Rated Power* (10.030), *Braking Resistor Thermal Time Constant* (10.031) and *Braking Resistor Resistance* (10.061) to 0 to disable the trip.

Trip	CAM
Value	99
Short description	

Advanced motion controller cam failure.

Sub-trip	Reason
1	<i>AMC Cam Start Index</i> (35.001) > <i>AMC Cam Size</i> (35.003) or <i>AMC Cam Start Position In Segment</i> (35.002) > Cam Table In for the start index
2	<i>AMC Cam Index</i> (35.007) has change by more than 2 in one sample
3	The rate of change at a segment boundary has exceeded the maximum value
4	The sum of the <i>AMC Cam Position In Segment</i> (35.008) and the change of master position has exceeded the maximum value

Trip	Card Access
Value	185
Short description	

A communications failure has occurred with a NV media card. If this occurs during a data transfer to the card then the file being written may be corrupted. If this occurs when data is being transferred from the card then the data transfer may be incomplete. If a parameter file is transferred to the drive and this trip occurs during the transfer the parameters are not saved to non-volatile memory, and so the original parameters can be restored by powering the drive down and up again.

Recommended actions:

- Check the NV media card is installed / located correctly.
- Replace the NV media card.

Trip	Card Boot
Value	177
Short description	

A write to a Menu 0 parameter has been initiated via the keypad by exiting edit mode and *Parameter Cloning* (11.042) is set up for auto or boot mode, but the necessary boot file has not been created on the NV media card fitted to the drive to take the new parameter value. This occurs when *Parameter Cloning* (11.042) is changed to auto or boot mode, but the drive is not subsequently reset. The action of resetting the trip will create the necessary file and prevent further trips.

If this trip occurs after the drive has attempted to transfer parameters from the NV media card to the drive at boot, then the following sub-trips will give the reason for the trip.

Sub-trip	Reason
1	Failed to open / read / close card file 001 when retrieving drive parameter data
2	Failed to open / write / close drive parameter file
11	Failed to open / read / close card file 001 when retrieving option module slot 1 parameter data
12	Failed to open / write / close option module slot 1 parameter file
21	Failed to open / read / close card file 001 when retrieving option module slot 2 parameter data
22	Failed to open / write / close option module slot 2 parameter file
31	Failed to open / read / close card file 001 when retrieving option module slot 3 parameter data
32	Failed to open / write / close option module slot 3 parameter file
41	Failed to open / read / close card file 001 when retrieving option module slot 4 parameter data
42	Failed to open / write / close option module slot 4 parameter file
3	Failed to open / read / close card file 002 when retrieving onboard user program
4	Failed to open / write / close onboard user program in the drive
5	Drive failed to restart following onboard user program update

Recommended actions:

- Ensure that *Parameter Cloning* (11.042) is correctly set, and then reset the drive to create the necessary file on the NV media card.
- Re-attempt the parameter write to the Menu 0 parameter.
- Ensure any option modules are correctly fitted
- Erase the file on the NV media card and recreate the bootable parameter file

Trip	Card Busy
Value	178
Short description	

An attempt has been made to access a file on a NV media card, but the file is already being accessed by an Option Module, such as one of the Applications modules. No data is transferred.

Recommended actions:

- Wait for the Option Module to finish accessing the NV media card and re-attempt the required function.

Trip	Card Compare
Value	188
Short description	

A compare has been carried out between a file on a NV media card and the drive and these are different and no other NV media card related trips have occurred.

Recommended actions:

- Set Pr *mm.000* to 0 to reset the trip.
- Check to ensure the correct data block on the NV media card has been used for the compare.

Trip	Card Data Exists
Value	179
Short description	

An attempt has been made to store data on a NV media card, but the file already exists. No data is transferred. The file should be erased first to prevent this trip.

Recommended actions:

- Erase the data in data location.
- Write data to an alternative data location.

Trip	Card Drive Mode
Value	187
Short description	

This trip is produced during a compare if the drive mode in the file on the NV media card is different from the current drive mode and the file is a parameter file. This trip is also produced if an attempt is made to transfer a parameter file where the source and target drive modes are different and the drive mode is outside the range allowed for the target drive.

Recommended actions:

- Ensure the destination drive supports the drive operating mode in the parameter file.
- Clear the value in *Pr mm.000* and reset the drive.
- Ensure destination derive operating mode is the same as the source parameter file.

Trip	Card Error
Value	182
Short description	

An attempt has been made to access a NV media card, but an error has been detected in the data structure on the card. Resetting this trip will cause the drive to erase the <MCDF> folder from the NV media card (if it exists) and create the correct folder structure. On an SD card, whilst this trip is still present, missing directories will be created, and if the header file is missing it will be created. The following sub-trip numbers are used with this trip.

Sub-trip	Reason
1	The required folder and file structure is not present.
2	The <000> file is corrupted.
3	Two or more files in the <MCDF> folder have the same file identification number.

Recommended actions:

- Erase all the data blocks and re-attempt the process.
- Ensure the card is located correctly.
- Replace the NV media card.

Trip	Card Full
Value	184
Short description	

An attempt has been made to write to a NV media card, but there is insufficient space available. No data is transferred.

Recommended actions:

- Delete a data block or the entire NV media card to create space.
- Replace the NV media card.

Trip	Card No Data
Value	183
Short description	

An attempt has been made to access a non-existent file on a NV media card. No data is transferred.

Recommended actions:

- Ensure data block number is correct.

Trip	Card Option
Value	180
Short description	

A parameter file has been transferred from a NV media card to the drive, but at least one of the option modules are difference between source and target drives. This trip does not stop the data transfer, but is a warning that the data for the option modules that are different will be set to the default values and not the values from the card. This trip also applies if a compare is performed between a parameter file on a card and the drive and the option

modules fitted are different between the source and target.

If this trip occurs after the drive has attempted to transfer parameters from the NV media card to the drive at boot, then the following sub-trips will give the reason for the trip.

Sub-trip	Reason
0	One or more option module in the drive differs to the booted image.
1	Option module missing from slot 1
2	Option module missing from slot 2
3	Option module missing from slot 3
4	Option module missing from slot 4

Recommended actions:

- Ensure the correct option modules are installed.
- Ensure the option modules are in the same option module slot as the parameter set stored.
- Press the red reset button to acknowledge that the parameters for one or more of the option modules installed will be at their default values.
- This trip can be suppressed by setting Pr *mm.000* to 9666 and resetting the drive.

Trip	Card Product
Value	175
Short description	

If *Drive Derivative* (11.028) or *Product Type* (11.063) are different between the source and target drives then this trip is initiated either at power-up or when the card is accessed. It will have one of the following sub-trip numbers:

Sub-trip	Reason
1	If <i>Drive Derivative</i> (11.028) is different between the source and target drives, this trip is initiated either at power-up or when the SD Card is accessed. Data is still transferred, since this is a warning trip; the trip can be suppressed by entering code 9666 in parameter xx.000, and resetting the drive (this applies the warning suppression flag to the card).
2	If <i>Product Type</i> (11.063) is different between the source and target drives or if corruption is detected in the parameter file, this trip is initiated either at power-up or when the SD Card is accessed. This trip can be reset but no data are transferred in either direction between the drive and the card.
3	A Unidrive SP parameter value was found that has no equivalent parameter on the destination drive. Data is still transferred, since this is a warning trip; the trip can be suppressed by entering code 9666 in parameter xx.000, and resetting the drive (this applies the warning suppression flag to the card).

Recommended actions:

- Use a different NV media card.
- This trip can be suppressed by setting Pr *mm.000* to 9666 and resetting the drive.

Trip	Card Rating
Value	186
Short description	

A parameter file has been transferred from a NV media card to the drive, but the current and/or voltage rating are different between source and target drive. This trip does not stop the data transfer, but is a warning that the data for rating dependent parameters may not be the same on the target as the source drive. This trip also applies if a compare (using Pr *mm.000* set to 8yyy) is performed between a parameter file on the card on the drive.

Recommended actions:

- Reset the drive to clear the trip.
- This trip can be suppressed by setting Pr *mm.000* to 9666 and resetting the drive.

Trip	Card Read Only
Value	181
Short description	

An attempt has been made to modify data on a read-only NV media card or to modify a read-only file (i.e. erase the card, erase a file or create a file). No data is transferred.

Recommended actions:

- Clear the read only flag by setting Pr *mm.000* to 9777 and reset the drive. This will clear the read only flag for all data blocks in the NV media card.

Trip	Card Slot
Value	174
Short description	

The transfer of an option module application program to or from an application module can fail because the option module does not respond correctly. If this happens this trip is produced with the sub-trip indicating the option module slot number.

Sub-trip number	Reason
1	Error in option slot 1
2	Error in option slot 2
3	Error in option slot 3
4	Error in option slot 4

Recommended actions:

- Ensure the source / destination option module is installed on the correct slot.

Trip	Cloning
Value	102
Short description	

If an attempt is made to use the cloning system to back-up the drive and option modules (parameter mm.000 values from 40001 to 40999) or restore the drive and option modules (parameter mm.000 values from 60001 to 60999) and the action fails then a "Cloning" trip is initiated. The sub-trip value indicates the reason for the trip.

Sub-trip	Reason
1	The option module in Slot 1 has indicated that it will either back-up or restore its data to/from an SD card, but has failed to respond correctly and the system has timed out.
2	As 1, but for Option Slot 2.
3	As 1, but for Option Slot 3.
4	As 1, but for Option Slot 4.
5	Back-up folders exist or cannot be created when a back-up is initiated.
6	The required back-up folders do not exist when a restore is initiated.

Trip	Configuration
Value	111
Short description	

The *Number Of Power Modules Detected* (11.071) is different from the number expected. The sub-trip value indicates the number of power modules expected.

Recommended actions:

- Ensure that all the power modules are correctly connected and powered up.
- Ensure that the value in *Number Of Power Modules Detected* (11.071) is set to the number of power modules connected.
- Set *Number Of Power Modules Test* (11.035) to 0 to disable the trip if not required.

This trip is also initiated if the number of external rectifiers connected to each power module is less than the number defined by *Number Of Rectifiers Expected* (11.096). If this is the reason for the trip the sub-trip is 10x where x is the number of external rectifiers that should be connected.

Recommended actions:

- Ensure that all the external rectifiers are connected correctly.
- Ensure that the value in *Number Of Rectifiers Expected* (11.096) is correct.

Trip	Control Word
Value	35
Short description	

This trip is initiated by setting bit 12 on the control word in *Control Word* (06.042) when the control word is enabled (*Control Word Enable* (06.043) = On).

Recommended actions:

- Check the value of *Control Word* (06.042).
- Disable the control word in *Control Word Enable* (06.043).

Trip	Current Offset
Value	225
Short description	

The current feedback offset is too large to be trimmed correctly. The sub-trip relates to the output phase for which the offset error has been detected.

Sub-trip	Phase
1	U
2	V
3	W

Recommended actions:

- Ensure that there is no possibility of current flowing in the output phase of the drive when the drive is not enabled.
- Hardware fault - contact the supplier of the drive.

Trip	Data Changing
Value	97
Short description	

A user action or a file system write is active that is changing the drive parameters and the drive has become active, i.e. *Drive Active* (10.002) = 1. The user actions that change drive parameters are loading defaults, changing drive mode, or transferring data from an NV memory card or a position feedback device to the drive. The file system actions that will cause this trip to be initiated if the drive is enabled during the transfer are writing a parameter or macro file to the drive, or transferring a derivative or user program to the drive. It should be noted that none of these actions can be started if the drive is active, and so the trip only occurs if the action is started and then the drive is enabled.

Recommended actions:

- Ensure the drive is not enabled when one of the following is being carried out:
 - Loading defaults
 - Changing drive mode
 - Transferring data from a NV media card or position feedback device
 - Transferring user programs

Trip	Derivative ID
Value	247
Short description	

There is a problem with the identifier associated with derivative image which customises the drive. The reason for the trip is given by the sub-trip as follows.

Sub-trip	Reason for trip
1	There should be a derivative image in the product but this has been erased.
2	The identifier is out of range.
3	The derivative image has been changed.

Trip	Derivative Image
Value	248
Short description	

An error has been detected in the derivative product image. The sub-trip indicated the reason for the trip.

Sub-trip	Reason	Comments
1	Divide by zero	
2	Undefined trip	
3	Attempted fast parameter access set-up with non-existent parameter	
4	Attempted access to non-existent parameter	
5	Attempted write to read-only parameter	
6	Attempted and over-range write	
7	Attempted read from write-only parameter	
30	The image has failed because either its CRC is incorrect, or there are less than 6 bytes in the image or the image header version is less than 5.	Occurs when the drive powers-up or the image is programmed. The image tasks will not run.
31	The image requires more RAM for heap and stack than can be provided by the drive.	As 30.
32	The image requires an OS function call that is higher than the maximum allowed.	As 30.
40	The timed task has not completed in time and has been suspended.	
41	Undefined function called, i.e. a function in the host system vector table that has not been assigned.	As 40.
51	Core menu customisation table CRC check failed	As 30.
52	Customisable menu table CRC check failed	As 30.
53	Customisable menu table changed	Occurs when the drive powers-up or the image is programmed and the table has changed. Defaults are loaded for the derivative menu and the trip will keep occurring until drive parameters are saved.
61	The option module fitted in slot 1 is not allowed with the derivative image.	As 30.
62	The option module fitted in slot 2 is not allowed with the derivative image.	As 30.
63	The option module fitted in slot 3 is not allowed with the derivative image.	As 30.
64	The option module fitted in slot 4 is not allowed with the derivative image.	As 30.
70	An option module that is required by the derivative image is not fitted in any slot.	As 30.
71	An option module specifically required to be fitted in slot 1 not present.	As 30.
72	An option module specifically required to be fitted in slot 2 not present.	As 30.
73	An option module specifically required to be fitted in slot 3 not present.	As 30.
74	An option module specifically required to be fitted in slot 4 not present.	As 30.
80	*Image is not compatible with the control board	Initiated from within the image code.
81	*Image is not compatible with the control board serial number	As 80.

Recommended actions:

- Contact the supplier of the drive.

Trip	Destination
Value	199
Short description	

This trip indicated that destination output parameters of two or more logic functions (Menus 05, 07, 08, 09, 12 or 14) within the drive are writing to the same parameter.

Recommended actions:

- Set Pr *mm.000* to "Destinations" or 12001 and check all visible parameters in all menus for parameter write conflicts.

Trip	Drive Size
Value	224
Short description	

This trip indicates that the control PCB has not recognized the drive size of the power circuit to which it is connected.

Recommended actions:

- Ensure the drive is programmed to the latest software version.
- Hardware fault - return drive to supplier.

Trip	EEPROM Fail
Value	31
Short description	

EEPROM Fail trip indicates that default parameters have been loaded because of the reasons given below.

Sub-trip	Reason
1	The most significant digit of the internal parameter database version number has changed.
2	The CRC's applied to the parameter data stored in internal non-volatile memory indicate that a valid set of parameters cannot be loaded.
3	The drive mode restored from internal non-volatile memory is outside the allowed range for the product or the derivative image does not allow the previous drive mode.
4	The drive derivative image has been changed and it has changed the customisation of the drive core menus.
5	The power stage hardware has been change and changed the customisation of the drive core menus.
6	The internal I/O hardware has been change and changed the customisation of the drive core menus.
7	The position feedback interface hardware has been change and changed the customisation of the drive core menus.
8	The control board hardware has been change and changed the customisation of the drive core menus.
9	The checksum on the non-parameter area of the EEPROM has failed.

The drive holds two banks of user save parameters and two banks of power down save parameters in non-volatile memory. If the last bank of either set of parameters that was saved is corrupted a *User Save* or *Power Down Save* trip is produced. If one of these trips occurs the parameters values that were last saved successfully are used. It can take some time to save parameters when requested by the user and if the power is removed from the drive during this process it is possible to corrupt the data in the non-volatile memory.

If both banks of user save parameters or both banks of power down save parameters are corrupted or one of the other conditions given in the table above occurs *EEPROM Fail.xxx* trip is produced. If this trip occurs it is not possible to use the data that has been saved previously, and so the drive will be in lowest allowed drive mode with default parameters. The trip can only be reset if *Parameter mm.000* (mm.000) is set to 10, 11, 1233 or 1244 or if *Load Defaults* (11.043) is set to a non-zero value.

Recommended actions:

- Default the drive and perform a drive reset.
- Allow sufficient time to perform a save before the supply to the drive is removed.
- If the trip persists, return drive to the supplier.

Trip	Encoder 1
Value	189
Short description	

Drive position feedback interface power supply overloaded. Terminals 13 & 14 of the 15 way D-type connector can supply a maximum current of 200mA at 15V or 300mA at 5V.

Recommended actions:

- Check encoder power supply wiring.
- Disable the termination resistors (*P1 Termination Select* (03.039) set to 0) to reduce current consumption.
- For 5V encoders with long cables, select 8V (*P1 Supply Voltage* (03.036)) and fit a 5V voltage regulator close to the encoder.
- Check the encoder specification to confirm it is compatible with the encoder port power supply current capability.
- Replace the encoder.
- Use an external power supply with higher current capability.

Trip	Encoder 2
Value	190
Short description	

There is a wire break between the drive and the position feedback device. These trips are provided for the P1 position feedback interface only and the exact cause of the trip can be identified from the sub-trip number as given below.

Sub-trip	Signals
1	Resolver or SINCOS sine wave signals
11	Digital incremental A signal
12	Digital incremental B signal
13	Digital incremental Z signal
14	SC SC device single turn sine wave commutation signals.
15	SC SC device marker

This trip can occur if the position feedback device type selected in *P1 Device Type* (03.038) is not correct for the position feedback device connected to the drive.

Recommended actions:

- Ensure that the position feedback device type selected in *P1 Device Type* (03.038) is correct for the position feedback device connected to the P1 interface on the drive.
- If wire break detection on the drive encoder input is not required, set bit 0 of *P1 Error Detection Level* (03.040) to 0 to disable the Encoder 2 trip.
- If the trip is due to the digital incremental Z (marker signal) this is often not connected. Check that this trip is disabled by setting *P1 Termination Select* (03.039) to a value that disables the termination on this input, which will disable hardware wire break detection.
- Check cable continuity.
- Check wiring of feedback signals is correct.
- Check encoder power supply is set correctly (*P1 Supply Voltage* (03.036)).
- Replace the encoder.

Trip	Encoder 3
Value	191
Short description	

The drive has detected an incorrect UVW phase angle while running (RFC-S mode only) or SINCOS phase error. The feedback device which has caused the trip can be identified by the sub-trip number.

Sub-trip	Reason
1	Drive position feedback interface 1
2	Drive position feedback interface 2

Recommended actions:

- Check encoder shield connections.
- Ensure the encoder cable is one uninterrupted cable.
- Check the encoder signal for noise with an oscilloscope.
- Check the integrity of the encoder mechanical mounting.
- For a UVW servo encoder, ensure that the phase rotation of the UVW commutation signals is the same as the phase rotation of the motor.
- For a SINCOS encoder, ensure that motor and incremental SINCOS connections are correct and that for forward rotation of the motor, the encoder rotates clockwise (when looking at the shaft of the encoder).
- Repeat the offset measurement test.

Trip	Encoder 4
Value	192
Short description	

This trip indicates that the encoder communications has timed out or the communications position message transfer time is too long. This trip can also be caused due to a wire break in the communication channel between the drive and the encoder. The feedback device which has caused the trip can be identified by the sub-trip number.

Sub-trip	Reason
1	Drive position feedback interface 1
2	Drive position feedback interface 2

Recommended actions:

- Ensure the encoder power supply setting (*P1 Supply Voltage* (03.036)) is correct.
- Complete encoder auto-configuration (*P1 Auto-configuration Select* (03.041) = Enabled).
- Check the encoder wiring.
- Replace the feedback device.

Trip	Encoder 5
Value	193
Short description	

This trip indicates that there is a checksum or CRC error, or the SSI encoder is not ready. The Encoder 5 trip can also indicate a wire break to a communications based encoder.

Sub-trip	Reason
1	Drive position feedback interface 1
2	Drive position feedback interface 2

Recommended actions:

- Check the encoder cable shield connections.
- Ensure the cable is one uninterrupted cable - remove any connector blocks or if unavoidable minimise the length of any shield pigtails to the connector block.
- Check the encoder signal for noise with an oscilloscope.
- Check *P1 Comms Bits* (03.035).
- If using a HiPerface, EnDat or BiSS encoder, carry out an encoder auto-configuration (*P1 Auto-configuration Select* (03.041) = Enabled).
- Replace the encoder.

Trip	Encoder 6
Value	194
Short description	

This trip indicates that the encoder has indicated an error or that the power supply has failed to an SSI encoder. This trip can also indicate a wire break to an SSI encoder.

Sub-trip	Reason
1	Drive position feedback interface 1
2	Drive position feedback interface 2

Recommended actions:

- For SSI encoders, check the wiring and encoder power supply setting (*P1 Supply Voltage* (03.036)).
- For BiSS encoders this trip will often occur if *P1 Comms Bits* (03.035) is not set correctly because a position or CRC bit may be read instead of the /Error bit.
- For SC HiPerface encoders this trip indicates that the encoder is detecting an error.
- Replace the encoder / contact the supplier of the encoder.

Trip	Encoder 7
Value	195
Short description	

A set-up parameter for the position feedback device has been changed. See *P1 Error Detection Level* (03.040).

Sub-trip	Reason
1	Drive position feedback interface 1
2	Drive position feedback interface 2

Trip	Encoder 8
Value	196
Short description	

This trip indicates that the position feedback interface communications time exceeds 250µs. The feedback device which has caused the trip can be identified by the sub-trip number.

Sub-trip	Reason
1	Drive position feedback interface 1
2	Drive position feedback interface 2

Recommended actions:

- Ensure the encoder is connected correctly.
- Ensure that the encoder is compatible.
- Increase baud rate.

Trip	Encoder 9
Value	197
Short description	

- This indicates that the position feedback selected from an option slot that does not contain a position feedback category option module.

Recommended action:

- Check the setting of *Motor Control Feedback Select* (03.026) (or *M2 Motor Control Feedback Select* (21.021) if the second motor parameters have been enabled).
- Ensure that the option slot selected in *Motor Control Feedback Select* (03.026) has a feedback option module installed.

Trip	Encoder 12
Value	162
Short description	

This trip indicates that the drive is communicating with the encoder but the encoder type is not recognised.

Sub-trip	Reason
1	Drive position feedback interface 1
2	Drive position feedback interface 2

Recommended actions:

- Enter the encoder setup parameters manually.
- Check to see if the encoder supports auto-configuration.

Trip	Encoder 13
Value	163
Short description	

This trip indicates that the data read from the encoder was out of range during auto-configuration. No parameters will be modified with data read from the encoder as a result of auto-configuration. The tens in the sub-trip number indicate the interface number (i.e. 1 for P1 interface and 2 for P2 interface).

Sub-trip	Reason
x1	Rotary lines per revolution error
x2	Linear comms pitch error
x3	Linear line pitch error
x4	Rotary turns bits error
x5	Communications bits error
x6	Calculation time is too long
x7	Line delay measured is longer than 5µs

Recommended actions:

- Enter the encoder setup parameters manually.
- Check to see if the encoder supports auto-configuration.

Trip	Encoder 14
Value	164
Short description	

The data given in the additional configuration parameter for a position feedback interface is out of range. If the sub-trip number is one then the data is out of range in *P1 Additional Configuration* (03.074), or if the sub-trip number is 2 the data is out of range in *P2 Additional Configuration* (03.174). Not all position feedback devices use the additional configuration, but those that do are listed below.

BISS

Range checking is applied to the turns padding (decimal digits 5-3) and position padding (decimal digits 2-0). If these give a padding value outside +/-16 then the trip is initiated. Note that in each case the most significant digit indicates left (0) or right (1) padding, and the least significant 2 digits indicate the number of bits.

Trip	External Trip
Value	6
Short description	

External trip is initiated as shown in the table below.

Sub-trip	Reason
1	<i>External Trip Mode</i> (08.010) = 1 or 3 and SAFE TORQUE OFF Input 1 is low
2	<i>External Trip Mode</i> (08.010) = 2 or 3 and SAFE TORQUE OFF Input 2 is low
3	<i>External Trip</i> (10.032) = 1

Recommended actions:

- Check the SAFE TORQUE OFF signal voltage on terminal 31 is 24V.
- Check the value of *STO Input 01 State* (08.009) which indicates the digital state of terminal 31.
- If external trip detection of the SAFE TORQUE OFF input is not required, set *External Trip Mode* (08.010) to Off (0).
- Check the value of *External Trip* (10.032).
- Select "Destinations" (or enter 12001) in Pr *mm.000* and check for a parameter controlling *External Trip* (10.032).
- Ensure *External Trip* (10.032) or *User Trip* (10.038) (=6) is not being used by serial comms.

Trip	I/O Overload
Value	26
Short description	

This trip indicates that the total current drawn from the 24V user supply or from the digital output has exceeded the limit. A trip is initiated if one or more of the following conditions:

- Maximum output current from one digital output is 100mA.
- The combined maximum output current from outputs 1 and 2 is 100mA.

- The combined maximum output current from output 3 and +24V output is 100mA.

Recommended actions:

- Check total loads on digital outputs.
- Check control wiring is correct.
- Check output wiring is undamaged.

Trip	Inductance
Value	8
Short description	

This trip occurs in RFC-S mode when the drive has detected that the motor inductances are not suitable for the operation being attempted. The trip is either caused because the ratio or difference between Ld and Lq is too small or because the saturation characteristic of the motor cannot be measured.

If the inductance ratio or difference is too small this is because one of the following conditions is true:

$$(No\text{-}load\ Lq\ (05.072) - Ld\ (05.024)) / Ld\ (05.024) < 0.1$$

$$(No\text{-}load\ Lq\ (05.072) - Ld\ (05.024)) < (K / Full\ Scale\ Current\ Kc\ (11.061))H$$

where:

Drive Rated Voltage (11.033)	K
200V	0.0073
400V	0.0146
575V	0.0174
690V	0.0209

If the saturation characteristic of the motor cannot be measured this is because when the flux in the motor is changed the measured value of Ld does not change sufficiently due to saturation to be measured. When half of *Rated Current* (05.007) is applied in the d axis of the motor in each direction the inductance must change by at least $(K / (2 \times Full\ Scale\ Current\ Kc\ (11.061))) H$.

The specific reasons for each of the sub-trips are given in the table below.

Sub-trip	Reason
1	The inductance ratio or difference is too small when the drive has been started in sensorless mode.
2	The saturation characteristic of the motor cannot be measured when the drive has been started in sensorless mode.
3	The inductance ratio or difference is too small when an attempt is made to determine the location of the motor flux during a stationary auto-tune in RFC-S mode. This trip is also produced when the inductance ratio or inductance difference is too small when carrying out a phasing test on starting in RFC-S mode. If position feedback is being used the measured value for <i>Position Feedback Phase Angle</i> (03.025) may not be reliable. Also the measured values of <i>Ld</i> (05.024) and <i>No-load Lq</i> (05.072) may not correspond to the d and q axis respectively.
4	The direction of the flux in the motor is detected by the change of inductance with different currents. This trip is initiated if the change cannot be detected when an attempt is made to perform a stationary auto-tune when position feedback is being used, or to perform a phasing test on starting in RFC-S mode.

Trip	Inductor Too Hot
Value	93
Short description	

Regen inductor overload. See *Inductor Thermal Time Constant* (04.015).

Trip	Inter-connect
Value	103
Short description	

Multi-power module drive interconnection cable error. The sub-trip "xx.0.00" indicates which power module has detected the fault where xx is the power module number. This trip is also initiated if the number of modules present changes from the number of modules detected at power-up. In this case the sub-trip is the number of modules that are still communicating correctly.

Trip	Island
Value	160
Short description	

This trip indicates that a regen system is connected to an islanded supply. The sub-trips indicate the reason for the trip.

Sub-trip	Reason
1	Island detection system has been enabled and detected an island condition
2	The minimum synchronisation voltage is non-zero and the supply voltage has been below this threshold and been simulating its own supply synchronisation for more than 2.0s.

Recommended actions:

- Check the supply / supply connections to the regen drive.

Trip	Keypad Mode
Value	34
Short description	

If keypad reference mode is enabled (*Reference Selected Indicator* (01.049) = 4 or 6) (i.e. *Reference Selector* (01.014) is set to 4 or 6 if motor map 1 is selected, or *M2 Reference Selector* (21.003) is set to 4 or 6 if motor map 2 is selected) and the keypad removed, then this trip is initiated.

Recommended actions:

- Re-install keypad and reset.
- Change *Reference Selector* (01.014) to select the reference from another source.

Trip	Line Sync
Value	39
Short description	

This trip indicates that the inverter has lost the synchronization with the ac supply in Regen mode.

Recommended actions:

- Check the supply / supply connections to the regen drive.

Trip	Low Load
Value	38
Short description	

This trip is initiated if the low load detector is set up to produce a trip on low load detection and this condition occurs. See *Enable Trip On Low Load* (04.029).

Trip	Motor Too Hot
Value	20
Short description	

This trip indicates a motor thermal overload based on the *Rated Current* (05.007) and *Motor Thermal Time Constant 1* (04.015). *Motor Protection Accumulator* (04.019) displays the motor temperature as a percentage of the maximum value. The drive will trip on *Motor Too Hot* when *Motor Protection Accumulator* (04.019) gets to 100%.

Recommended actions:

- Ensure the load is not jammed / sticking.
- Check the load on the motor has not changed.
- If seen during an auto-tune test in RFC-S mode, ensure the *Rated Current* (05.007) is = Heavy duty current rating of the drive.
- Tune the *Rated Speed* (05.008) (RFC-A mode only).
- Check feedback signal for noise.
- Ensure the motor rated current is not zero.

Trip	Name Plate
Value	176
Short description	

This trip is initiated if there is a problem detected when an electronic name plate transfer from the motor to the drive is initiated. The reasons for the trip are given below:

Sub-trip	Reason	Details
1	A communication error with the encoder has been detected.	It is unlikely that this sub-trip will occur as most encoder errors will cause an encoder trip. It is possible that incorrect data in the nameplate could cause this trip, and so the nameplate data should be verified.
2	A data error has been detected in the nameplate. This is either because the number of entries is out of range, i.e. less than 1 or greater than 168, or the calculated CRC does not match the CRC from the nameplate.	Either there is no valid nameplate in the position feedback device or there is a data error in the nameplate area.
3	The exchange with the encoder has timed out.	If the encoder is connected to a drive interface, then this occurs because the encoder is not connected to the drive or is not initialised. If the encoder is connected to an option module interface, then this occurs because the position feedback interface (i.e. P1 or P2) is not present on the option module, or a suitable position feedback device is not selected, or because no device is connected, or it is not initialised.

Trip	None
Value	0
Short description	

No trip has been stored in this position in the trip log.

Trip	OHT Brake
Value	101
Short description	

This trip indicates that braking IGBT over-temperature has been detected based on firmware thermal model.

Recommended actions:

- Check braking resistor value is greater than or equal to the minimum resistance value.

Trip	OHT Control
Value	23
Short description	

This trip indicates that a control stage over-temperature has been detected. From the sub-trip "xxyzz", the cause of the trip can be identified as follows:

Source	xx	y	zz
Control system	00	0	01: Control board thermistor 1
Control system	00	0	02: Control board thermistor 2
Control system	00	0	03: I/O board thermistor (or brake resistor thermistor)

Recommended actions:

- Check enclosure / drive fans are still functioning correctly.
- Check enclosure ventilation paths.
- Check enclosure door filters.
- Increase ventilation.
- Reduce the drive switching frequency.
- Check ambient temperature.

Trip	OHT dc bus
Value	27
Short description	

This trip indicates a DC bus component over temperature based on a firmware thermal model. The drive includes a thermal protection system to protect the DC bus components within the drive. This includes the effects of the output current and DC bus ripple. The estimated temperature is displayed as a percentage of the trip level in *Percentage Of d.c. Link Thermal Trip Level* (07.035). If this parameter reaches 100% then an *OHT dc bus* trip with sub-trip 200 is initiated. The drive will attempt to stop the motor before tripping. If the motor does not stop in 10 seconds then the drive trips immediately.

Source	xx	y	zz
Control system	00	2	00: D.c. link thermal model gives {OHT dc bus} trip with sub-trip 0.

It is also possible in a multi-power module system for d.c. link over-temperature to be detected from within the power stage. From this source the estimated temperature as a percentage of trip is not available and the trip is indicated as follows:

Source	xx	y	zz
Control system	01	0	00: Power stage gives {OHT dc bus} trip with sub-trip 0.

Recommended actions:

- Check the AC supply voltage balance and levels.
- Check the DC bus ripple level.
- Reduce duty cycle.
- Reduce motor load.
- Check output current stability. If unstable;
 - Check the motor map settings with motor nameplate (*Rated Frequency* (05.006), *Rated Current* (05.007), *Rated Speed* (05.008), *Rated Voltage* (05.009), *Rated Power Factor* (05.010) and *Number Of Motor Poles* (05.011)) - (All modes).
 - Disable slip compensation (*Enable Slip Compensation* (05.027) = Off (0)) - (Open-loop).
 - Disable dynamic V to F operation (*Dynamic V To F Select* (05.013) = Off (0)) - (Open-loop).
 - Select fixed boost (*Open-loop Control Mode* (05.014) = Fixed (2)) - (Open-loop).
 - Select high stability space vector modulation (*High Stability Space Vector Modulation* (05.019) = On (1)) - (Open-loop).
 - Disconnect the load and complete a rotating auto-tune (*Auto-tune* (05.012) = 2) - (RFC-A and RFC-S).
 - Auto-tune the rated speed value (*Rated Speed Optimisation Select* (05.016) = 1) - (RFC-A and RFC-S).
 - Reduce speed loop gains (*Speed Controller Proportional Gain Kp1* (03.010), *Speed Controller Integral Gain Ki1* (03.011) and *Speed Controller Differential Feedback Gain Kd1* (03.012)) - (RFC-A and RFC-S).
 - Add a speed feedback filter value (*P1 Feedback Filter* (03.042)) - (RFC-A and RFC-S).

- Add a current demand filter (*Current Reference Filter 1 Time Constant* (04.012)) - (RFC-A and RFC-S).
- Check encoder signals for noise with an oscilloscope - (RFC-A and RFC-S).
- Check encoder mechanical coupling - (RFC-A and RFC-S).

Trip	<i>Oht Inverter</i>
Value	21
Short description	

This trip indicates that an IGBT junction over-temperature has been detected based on a firmware thermal model. The sub-trip indicates which model has initiated the trip in the form xyyzz as given below.

Source	xx	y	zz
Control system	00	1	00: Inverter thermal model
Control system	00	3	00: Braking IGBT thermal model
Control system	00	4	00: Rectifier thermal model

Recommended actions with sub-trip 100:

- Reduce the selected drive switching frequency.
- Ensure *Auto-switching Frequency Change* (05.035) is set to Enabled (0).
- Reduce duty cycle.
- Decrease acceleration / deceleration rates.
- Reduce motor load.
- Check the DC bus ripple.
- Ensure all three input phases are present and balanced.

Recommended actions with sub-trip 300:

- Reduce the braking load.

Recommended actions with sub-trip 400:

- Check the AC supply voltage balance and levels.
- Check the DC bus ripple level.
- Reduce duty cycle.
- Reduce motor load.

Trip	<i>Oht Power</i>
Value	22
Short description	

This trip indicates that a power stage over-temperature has been detected. The sub-trip "xyzz" indicates which thermistor is indicating the over-temperature. The thermistor numbering is different for a single module type drive (i.e. no parallel board fitted) and a multi-module type drive (i.e. parallel board fitted with one or more power modules) as shown below:

Single module type drive:

Source	xx	y	zz
Power system	01	0	zz: Thermistor location defined by zz in the power board
Power system	01	Rectifier number	zz: Thermistor location defined by zz in the rectifier

Multi-module type system:

Source	xx	y	zz
Power system	Power module number	0	01: U phase power device
Power System	Power module number	0	02: V phase power device
Power system	Power module number	0	03: W phase power device
Power system	Power module number	0	04: Rectifier
Power system	Power module number	0	05: General power system
Power system	Power module number	0	00: Braking IGBT

Note that the power module that has caused the trip cannot be identified except for the braking IGBT temperature measurement

Recommended actions:

- Check enclosure / drive fans are still functioning correctly.
- Force the heatsink fans to run at maximum speed.
- Check enclosure ventilation paths.
- Check enclosure door filters.
- Increase ventilation.
- Reduce duty cycle.
- Decrease acceleration / deceleration rates.
- Reduce motor loads.
- Check the derating tables and confirm the drive is correctly sized for the application.
- Use a drive with larger current / power rating.

Trip	OI ac
Value	3
Short description	

This trip indicates that the instantaneous drive output current has exceeded the drive over current threshold.

Source	xx	y	zz
Control system	00	0	00: Instantaneous over-current trip when the measured a.c. current exceeds over current threshold
Power system	Power module number	0	00: Instantaneous over-current trip when the measured a.c. current exceeds over current threshold.

The over current threshold is the maximum current the drive can measure and is defined by VM_DRIVE_CURRENT[MAX].

Recommended actions:

- Acceleration / deceleration rate is too short.
- If seen during auto-tune reduce the voltage boost.
- Check for short circuit on the output cabling.
- Check integrity of the motor insulation using a Megger.
- Check feedback device wiring.
- Check feedback drive mechanical coupling.
- Check feedback signals are free from noise.
- Check motor cable is within limits for the frame size.
- Reduce the speed loop gains (*Speed Controller Proportional Gain Kp1* (03.010), *Speed Controller Integral Gain Ki1* (03.011), *Speed Controller Differential Feedback Gain Kd1* (03.012)).
- Check that the phase angle auto-tune has been completed (RFC-S mode only).
- Reduce the current loop gains (RFC-A and RFC-S modes only).

Trip	OI Brake
Value	4
Short description	

This trip indicates that an over-current has been detected in braking IGBT or braking IGBT protection has been activated. The braking IGBT over-current trip is detected within the power system. If the drive is a single module drive then there is no sub-trip. If the drive is a multi-power module drive the following sub-trip is used to indicate the source of the trip.

Source	xx	y	zz
Power system	Power module number	0	00: Braking IGBT instantaneous over-current trip

Recommended actions:

- Check brake resistor wiring.
- Check braking resistor value is greater than or equal to the minimum resistance value.
- Check braking resistor insulation.

Trip	OI dc
Value	109
Short description	

This trip indicates that the short circuit protection for the drive output stage has been activated. The table below shows where the trip has been detected.

Source	xx	y	zz
Control system	00	0	00
Power system	Power module number	0	00

Recommended actions:

- Disconnect the motor cable at the drive end and check the motor and cable insulation with a Megger.
- Replace the drive.

Trip	<i>Ol Snubber</i>
Value	92
Short description	

This trip indicates that an over-current condition has been detected in the rectifier snubbing circuit, The exact cause of the trip can be identified by the sub-trip number.

Source	xx	y	zz
Power system	01	Rectifier number*	00: Rectifier snubber over-current trip detected.

*For a parallel power-module system the rectifier number will be one as it is not possible to determine which rectifier has detected the fault.

Recommended actions:

- Ensure the internal EMC filter is installed.
- Ensure the motor cable length does not exceed the maximum for selected switching frequency.
- Check for supply voltage imbalance.
- Check for supply disturbance such as notching from a DC drive.
- Check the motor and motor cable insulation with a Megger.
- Fit an output line reactor or sinusoidal filter.

Trip	<i>Option Disable</i>
Value	215
Short description	

During drive mode changeover option modules must acknowledge that they have stopped accessing the communications system between the option slots and the drive. If an option module does not do this in the allowed time then this trip is produced.

Recommended actions:

- Reset the trip.
- If the trip persists, replace the option module.

Trip	<i>Out Phase Loss</i>
Value	98
Short description	

This trip indicates that phase loss has been detected at the drive output.

Sub-trip	Reason
1	U phase output not connected when drive is enabled*
2	V phase output not connected when drive is enabled*
3	W phase output not connected when drive is enabled*
4	Output phase loss detected when the drive is running
5	U phase lower IGBT failure detection on drive enable
6	V phase lower IGBT failure detection on drive enable
7	W phase lower IGBT failure detection on drive enable

*These sub-trips could also indicate that the upper IGBT has failed in the indicated phase.

Note that if *Reverse Output Phase Sequence* (05.042) = 1 the physical output phases are reversed, and so sub-trip 3 refers to physical output phase V and sub-trip 2 refers to physical output phase W.

Recommended actions:

- Check motor and drive connections.
- To disable the trip set *Output Phase Loss Detection Enable* (06.059) to zero.

Trip	<i>Over Speed</i>
Value	7
Short description	

In open-loop mode, if the *Output Frequency* (05.001) exceeds the threshold set in *Over Speed Threshold* (03.008) in either direction, an *Over Speed* trip is produced. In RFC-A and RFC-S modes, if the *Speed Feedback* (03.002) exceeds the threshold set in *Over Speed Threshold* (03.008) in either direction, an *Over Speed* trip is produced. If *Over Speed Threshold* (03.008) is set to 0.0 the threshold is then equal to 1.2 x the value set in *Maximum Reference Clamp* (01.006).

In RFC-A and RFC-S modes if an SSI encoder is being used and *P1 SSI Incremental Mode* (03.047) is set to Off, an *Over Speed* trip will be reproduced when the encoder passes through the boundary between its maximum position and zero.

Recommended actions:

- Reduce the *Speed Controller Proportional Gain Kp1* (03.010) to reduce the speed overshoot (RFC-A and RFC-S modes only).
- If an SSI encoder is being used, set *P1 SSI Incremental Mode* (03.047) to On.

The above description relates to a standard over speed trip, however in RFC-S mode it is possible to produce an Overspeed trip with sub-trip 1. This is

caused if the speed is allowed to exceed the safe level in RFC-S mode with flux weakening. See *Enable High Speed Mode (05.022)* for details.

Trip	Over Volts
Value	2
Short description	

This trip indicates that the DC bus voltage has exceeded VM_DC_VOLTAGE[MAX] or VM_DC_VOLTAGE_SET[MAX] for 15s. The trip threshold varies depending on voltage rating of the drive as shown below.

Voltage rating	VM_DC_VOLTAGE[MAX]	VM_DC_VOLTAGE_SET[MAX]
200	415	410
400	830	815
575	990	970
690	1190	1175

The exact cause of the trip can be identified by the sub-trip number.

Source	xx	y	zz
Control system	00	0	01: Instantaneous trip when the d.c. link voltage exceeds VM_DC_VOLTAGE[MAX].
Control system	00	0	02: Time delayed trip indicating that the d.c. link voltage is above VM_DC_VOLTAGE_SET[MAX].

Recommended actions:

- Increase deceleration ramp.
- Decrease the braking resistor value (staying above the minimum value).
- Check nominal AC supply level.
- Check for supply disturbances which could cause the DC bus level to rise.
- Check motor insulation using a Megger.

Trip	Phase Loss
Value	32
Short description	

This trip does not occur in Regen mode.

Trip	Power Comms
Value	90
Short description	

A Power Comms trip indicates a communications problem within the power system of the drive. The reason for the trip can be identified by the sub-trip number.

Type of drive	xx	y	zz
Single power module system	01	Rectifier number*	00: Excessive communications errors detected by the rectifier module.

*For a parallel power-module system the rectifier number will be one as it is not possible to determine which rectifier has detected the fault.

Recommended actions:

- Hardware fault - contact the supplier of the drive.

Trip	Power Data
Value	220
Short description	

This trip can be generated either from the drive control system or from the power system.

This trip is produced if there is an error in the configuration data stored in the power system. If the source of the trip is the control system then the trip related to the table that is uploaded from the power system at power-up.

Source	xx	y	zz
Control system	00	0	02: There is no data table to be uploaded to the control board.
Control system	00	0	03: The power system data table is bigger than the space available in the control pod to store it.
Control system	00	0	04: The size of the table given in the table is incorrect
Control system	00	0	05: Table CRC error.
Control system	00	0	06: The version number of the generator software that produced the table is too low, i.e. a table from a newer generator is required that includes features that have been added to the table that may not be present.
Control system	00	0	07: The power board data table does not match the power board hardware identifier.
Power system	01	0	00: The power data table used internally by the power module has an error. (For a multi-power module drive this indicates any error with the code tables in the power system.)
Power system	01	0	01: The power data table that should be uploaded to the control system on power up has an error.
Power system	01	0	02: The power data table used internally by the power module does not match the hardware identification of the power module.

Recommended actions:

- Hardware fault - contact the supplier of the drive.

Trip	Power Down Save
Value	37
Short description	

This trip indicates that an error has been detected in the power down save parameters stored in non-volatile memory.

Recommended actions:

- Perform a 1001 save in Pr *mm.000* to ensure that the trip doesn't occur the next time the drive is powered up.

Trip	PSU
Value	5
Short description	

This trip indicates that one or more internal power supply rails are outside limits or overloaded.

Source	xx	Y	zz
Control system	00	0	00: Internal power supply overload.
Power system	Power module number	Rectifier number*	00: Rectifier internal power supply overload.

*For a parallel power-module system the rectifier number will be zero as it is not possible to determine which rectifier has detected the fault.

Recommended actions:

- Remove any option modules and perform a reset.
- Remove encoder connection and perform a reset.
- Hardware fault within the drive - return the drive to the supplier.

Trip	PSU 24V
Value	9
Short description	

The total user load of the drive and option modules has exceeded the internal 24V power supply limit. The user load consists of the drive digital outputs and main encoder supply.

Recommended actions:

- Reduce the load and reset.
- Provide an external 24V power supply on control terminal 2.
- Remove all option modules.

Trip	Rating Mismatch
Value	223
Short description	

This trip indicates that there is a voltage rating or current rating mismatch in a multi-module drive system. This trip is only applicable to modular drives that are connected in parallel. A mixture of power modules with different voltage or current ratings within the same multi-module drive system is not

allowed and will cause a *Rating Mismatch* trip.

Recommended actions:

- Ensure that all modules in a multi-modular drive system are of the same frame size and rating (voltage and current).
- Hardware fault - contact the supplier of the drive.

Trip	Rectifier Set-up
Value	94
Short description	

A rectifier has not been set-up correctly in a multi-power module system.

Recommended actions:

- Check the inter-power module wiring

Trip	Reserved 001
Value	1
Short description	

This trip value is used in Unidrive SP for an under voltage trip. The under voltage condition is now a drive state, and so this trip is no longer used by the drive.

Trip	Reserved 095
Value	95
Short description	

Reserved trip number.

Trip	Reserved 104
Value	104
Short description	

Reserved trip number.

Trip	Reserved 105
Value	105
Short description	

Reserved trip number.

Trip	Reserved 106
Value	106
Short description	

Reserved trip number.

Trip	Reserved 107
Value	107
Short description	

Reserved trip number.

Trip	Reserved 108
Value	108
Short description	

Reserved trip number.

Trip	Reserved 161
Value	161
Short description	

Reserved trip number.

Trip	Reserved 165
Value	165
Short description	

Reserved trip number.

Trip	Reserved 166
Value	166
Short description	

Reserved trip number.

Trip	Reserved 167
Value	167
Short description	

Reserved trip number.

Trip	Reserved 168
Value	168
Short description	

Reserved trip number.

Trip	Reserved 171
Value	171
Short description	

Reserved trip number.

Trip	Reserved 172
Value	172
Short description	

Reserved trip number.

Trip	Reserved 173
Value	173
Short description	

Reserved trip number.

Trip	Reserved 222
Value	222
Short description	

If this trip occurs please consult the drive supplier.

Trip	Reserved 228
Value	228
Short description	

If this trip occurs please consult the drive supplier.

Trip	Reserved 229
Value	229
Short description	

Reserved trip number.

Trip	Reserved 230
Value	230
Short description	

Reserved trip number.

Trip	Reserved 231
Value	231
Short description	

Reserved trip number.

Trip	Reserved 232
Value	232
Short description	

Reserved trip number.

Trip	Reserved 233
Value	233
Short description	

Reserved trip number.

Trip	Reserved 234
Value	234
Short description	

Reserved trip number.

Trip	Reserved 235
Value	235
Short description	

Reserved trip number.

Trip	Reserved 236
Value	236
Short description	

Reserved trip number.

Trip	Reserved 237
Value	237
Short description	

Reserved trip number.

Trip	Reserved 238
Value	238
Short description	

Reserved trip number.

Trip	Reserved 239
Value	239
Short description	

Reserved trip number.

Trip	Reserved 240
Value	240
Short description	

Reserved trip number.

Trip	Reserved 241
Value	241
Short description	

Reserved trip number.

Trip	Reserved 242
Value	242
Short description	

Reserved trip number.

Trip	Reserved 243
Value	243
Short description	

Reserved trip number.

Trip	Reserved 244
Value	244
Short description	

Reserved trip number.

Trip	Reserved 245
Value	245
Short description	

Reserved trip number.

Trip	Reserved 246
Value	246
Short description	

Reserved trip number.

Trip	Reset
Value	100
Short description	

This is not a valid trip number as this value is used in *User Trip* (10.038) to reset the drive.

Trip	Reset Logs
Value	255
Short description	

This is not a valid trip number as this value is used in *User Trip* (10.038) to reset the trip logs.

Trip	Resistance
Value	33
Short description	

This trip indicates that either the value being used for motor stator resistance is too high or that an attempt to do a test involving measuring motor stator resistance has failed. The maximum for the stator resistance parameters is generally higher than the maximum value that can be used in the control algorithms. If the value exceeds $(V_{FS} / \sqrt{2}) / \text{Full Scale Current } Kc$ (11.061), where V_{FS} is the full scale d.c. link voltage defined by VM_DC_VOLTAGE, then this trip is initiated. If the value is the result of a measurement made by the drive then sub-trip 1 is applied, or if it is because the parameter has been changed by the user then sub-trip 3 is applied. During the stator resistance section of auto-tuning an additional test is performed to measure the drive inverter characteristics to provide the compensation necessary for dead-times. If the inverter characteristic measurement fails then sub-trip 2 is applied.

Sub-trip	Reason
1	Measured stator resistance exceeded the allowed range
2	It was not possible to measure the inverter characteristic
3	The stator resistance associated with the presently selected motor map exceeds the allowed range

Recommended actions:

- Check that a value has not been entered in the stator resistance for the presently selected motor map does not exceed the allowed range.
- Check the motor cable / connections.
- Check the integrity of the motor stator winding using an insulation tester.
- Check the motor phase to phase resistance at the drive terminals.
- Check the motor phase to phase resistance at the motor terminals.
- Ensure the stator resistance of the motor falls within the range of the drive model.
- Select fixed boost mode (*Open-loop Control Mode* (05.014) = Fixed) and verify the output current waveforms with an oscilloscope.
- Replace the motor.

Trip	Slot1 Different
Value	204
Short description	

If the option module fitted in option slot 1 is different to the option module present at the last power-down then this trip is produced. The sub-trip number gives the identification code of the module that was originally fitted. The priority order for the option module different trips is *Slot1 Different* highest, then *Slot2 Different*, then *Slot3 Different* then *Slot4 Different*. Drive user parameters must be saved to prevent this trip on the next power-up if the module has changed. If the menus have been changed, but not the module, the trip will not occur on the next power-up. The sub-trip number gives the following indications of the reason for the trip.

Sub-trip	Reason
1	No module was fitted previously
2	A module with the same identifier is fitted, but the set-up menu for this option slot has been changed, and so default parameters have been loaded for this menu.
3	A module with the same identifier is fitted, but the applications menu for this option slot has been changed, and so default parameters have been loaded for this menu.
4	A module with the same identifier is fitted, but the set-up and applications menu for this option slot have been changed, and so default parameters have been loaded for these menus.
>99	Shows the identifier of the module previously fitted.

Recommended actions:

- Turn off the power, ensure the correct option modules are installed in the correct option slots and re-apply the power.
- Confirm that the currently installed option module is correct, ensure option module parameters are set correctly and perform a user save in Pr *mm.000*.

Trip	Slot1 Error
Value	202
Short description	

The option module in option slot 1 has indicated an error. The option module can give the reason for the error and this is shown in the sub-trip number. As default the sub-trip number is shown as a number on the display, however, it is possible for the option module to supply sub-trip number strings which will be displayed instead of the number if available.

Recommended actions:

- See relevant *Option Module User Guide* for details of the trip.

Trip	Slot1 HF
Value	200
Short description	

This trip indicates that there is a fault with the option module in option slot 1 that means that this module cannot operate. The possible causes of the trip are given by the sub-trip value.

Sub-trip	Reason
1	The module category cannot be identified
2	All the required customisable menu table information has not been supplied or the tables supplied are corrupt
3	There is insufficient memory available to allocate the comms buffers for this module.
4	The module has not indicated that it is running correctly during drive power-up
5	The module has been removed after power-up or it has ceased to indicate to the drive processor that it is still active.
6	The module has not indicated that it has stopped accessing drive parameters during a drive mode change
7	The module has failed to acknowledge that a request has been made to reset the drive processor.
8	The drive failed to read correctly the menu table from the module during drive power-up.
9	The drive failed to upload menu tables from the module and timed-out (5s).
10	Menu table CRC invalid.

Recommended actions:

- Ensure the option module is installed correctly.
- Replace the option module.
- Replace the drive.

Trip	Slot1 Not Fitted
Value	203
Short description	

Each option module fitted in the drive is identified at power-up and the option fitted is stored by the drive in its non-volatile memory. If an option module was fitted in slot 1 at power-down, but that option module has subsequently been removed before power up then this trip is produced. The sub-trip number gives the identification code of the option module that has been removed. The priority order for the option module not fitted trips is *Slot1 Not Fitted* highest, then *Slot2 Not Fitted*, then *Slot3 Not Fitted* then *Slot4 Not Fitted*. Drive user parameters must be saved to prevent this trip on the next power-up.

Recommended actions:

- Ensure the option module is installed correctly.
- Re-install the option module.
- To confirm that the removed option module is no longer required perform a save function in Pr *mm.000*.

Trip	Slot1 Watchdog
Value	201
Short description	

This trip indicates that the option module in option slot 1 has started the option watchdog function and then failed to service this watchdog correctly.

Recommended actions:

- Replace the option module.

Trip	Slot2 Different
Value	209
Short description	

If the option module fitted in option slot 2 is different to the option module present at the last power-down then this trip is produced. The sub-trip number gives the identification code of the module that was originally fitted. The priority order for the option module different trips is *Slot1 Different* highest, then *Slot2 Different*, then *Slot3 Different* then *Slot4 Different*. Drive user parameters must be saved to prevent this trip on the next power-up if the module has changed. If the menus have been changed, but not the module, the trip will not occur on the next power-up. The sub-trip number gives the following indications of the reason for the trip.

Sub-trip	Reason
1	No module was fitted previously
2	A module with the same identifier is fitted, but the set-up menu for this option slot has been changed, and so default parameters have been loaded for this menu.
3	A module with the same identifier is fitted, but the applications menu for this option slot has been changed, and so default parameters have been loaded for this menu.
4	A module with the same identifier is fitted, but the set-up and applications menu for this option slot have been changed, and so default parameters have been loaded for these menus.
>99	Shows the identifier of the module previously fitted.

Recommended actions:

- Turn off the power, ensure the correct option modules are installed in the correct option slots and re-apply the power.
- Confirm that the currently installed option module is correct, ensure option module parameters are set correctly and perform a user save in Pr *mm.000*.

Trip	Slot2 Error
Value	207
Short description	

The option module in option slot 2 has indicated an error. The option module can give the reason for the error and this is shown in the sub-trip number. As default the sub-trip number is shown as a number on the display, however, it is possible for the option module to supply sub-trip number strings which will be displayed instead of the number if available.

Recommended actions:

- See relevant *Option Module User Guide* for details of the trip.

Trip	Slot2 HF
Value	205
Short description	

This trip indicates that there is a fault with the option module in option slot 2 that means that this module cannot operate. The possible causes of the trip are given by the sub-trip value.

Sub-trip	Reason
1	The module category cannot be identified
2	All the required customisable menu table information has not been supplied or the tables supplied are corrupt
3	There is insufficient memory available to allocate the comms buffers for this module.
4	The module has not indicated that it is running correctly during drive power-up
5	The module has been removed after power-up or it has ceased to indicate to the drive processor that it is still active.
6	The module has not indicated that it has stopped accessing drive parameters during a drive mode change
7	The module has failed to acknowledge that a request has been made to reset the drive processor.
8	The drive failed to read correctly the menu table from the module during drive power-up.
9	The drive failed to upload menu tables from the module and timed-out (5s).
10	Menu table CRC invalid.

Recommended actions:

- Ensure the option module is installed correctly.
- Replace the option module.
- Replace the drive.

Trip	Slot2 Not Fitted
Value	208
Short description	

Each option module fitted in the drive is identified at power-up and the option fitted is stored by the drive in its non-volatile memory. If an option module was fitted in slot 2 at power-down, but that option module has subsequently been removed before power up then this trip is produced. The sub-trip number gives the identification code of the option module that has been removed. The priority order for the option module not fitted trips is *Slot1 Not Fitted* highest, then *Slot2 Not Fitted*, then *Slot3 Not Fitted* then *Slot4 Not Fitted*. Drive user parameters must be saved to prevent this trip on the next power-up.

Recommended actions:

- Ensure the option module is installed correctly.
- Re-install the option module.
- To confirm that the removed option module is no longer required perform a save function in Pr *mm.000*.

Trip	Slot2 Watchdog
Value	206
Short description	

This trip indicates that the option module in option slot 2 has started the option watchdog function and then failed to service this watchdog correctly.

Recommended actions:

- Replace the option module.

Trip	Slot3 Different
Value	214
Short description	

If the option module fitted in option slot 3 is different to the option module present at the last power-down then this trip is produced. The sub-trip number

gives the identification code of the module that was originally fitted. The priority order for the option module different trips is *Slot1 Different* highest, then *Slot2 Different*, then *Slot3 Different* then *Slot4 Different*. Drive user parameters must be saved to prevent this trip on the next power-up if the module has changed. If the menus have been changed, but not the module, the trip will not occur on the next power-up. The sub-trip number gives the following indications of the reason for the trip.

Sub-trip	Reason
1	No module was fitted previously
2	A module with the same identifier is fitted, but the set-up menu for this option slot has been changed, and so default parameters have been loaded for this menu.
3	A module with the same identifier is fitted, but the applications menu for this option slot has been changed, and so default parameters have been loaded for this menu.
4	A module with the same identifier is fitted, but the set-up and applications menu for this option slot have been changed, and so default parameters have been loaded for these menus.
>99	Shows the identifier of the module previously fitted.

Recommended actions:

- Turn off the power, ensure the correct option modules are installed in the correct option slots and re-apply the power.
- Confirm that the currently installed option module is correct, ensure option module parameters are set correctly and perform a user save in *Pr mm.000*.

Trip	Slot3 Error
Value	212
Short description	

The option module in option slot 3 has indicated an error. The option module can give the reason for the error and this is shown in the sub-trip number. As default the sub-trip number is shown as a number on the display, however, it is possible for the option module to supply sub-trip number strings which will be displayed instead of the number if available.

Recommended actions:

- See relevant *Option Module User Guide* for details of the trip.

Trip	Slot3 HF
Value	210
Short description	

This trip indicates that there is a fault with the option module in option slot 3 that means that this module cannot operate. The possible causes of the trip are given by the sub-trip value.

Sub-trip	Reason
1	The module category cannot be identified
2	All the required customisable menu table information has not been supplied or the tables supplied are corrupt
3	There is insufficient memory available to allocate the comms buffers for this module.
4	The module has not indicated that it is running correctly during drive power-up
5	The module has been removed after power-up or it has ceased to indicate to the drive processor that it is still active.
6	The module has not indicated that it has stopped accessing drive parameters during a drive mode change
7	The module has failed to acknowledge that a request has been made to reset the drive processor.
8	The drive failed to read correctly the menu table from the module during drive power-up.
9	The drive failed to upload menu tables from the module and timed-out (5s).
10	Menu table CRC invalid.

Recommended actions:

- Ensure the option module is installed correctly.
- Replace the option module.
- Replace the drive.

Trip	Slot3 Not Fitted
Value	213
Short description	

Each option module fitted in the drive is identified at power-up and the option fitted is stored by the drive in its non-volatile memory. If an option module was fitted in slot 3 at power-down, but that option module has subsequently been removed before power up then this trip is produced. The sub-trip number gives the identification code of the option module that has been removed. The priority order for the option module not fitted trips is *Slot1 Not Fitted* highest, then *Slot2 Not Fitted*, then *Slot3 Not Fitted* then *Slot4 Not Fitted*. Drive user parameters must be saved to prevent this trip on the next power-up.

Recommended actions:

- Ensure the option module is installed correctly.
- Re-install the option module.
- To confirm that the removed option module is no longer required perform a save function in Pr *mm.000*.

Trip	Slot3 Watchdog
Value	211
Short description	

This trip indicates that the option module in option slot 3 has started the option watchdog function and then failed to service this watchdog correctly.

Recommended actions:

- Replace the option module.

Trip	Slot4 Different
Value	254
Short description	

If the option module fitted in option slot 4 is different to the option module present at the last power-down then this trip is produced. The sub-trip number gives the identification code of the module that was originally fitted. The priority order for the option module different trips is *Slot1 Different* highest, then *Slot2 Different*, then *Slot3 Different* then *Slot4 Different*. Drive user parameters must be saved to prevent this trip on the next power-up if the module has changed. If the menus have been changed, but not the module, the trip will not occur on the next power-up. The sub-trip number gives the following indications of the reason for the trip.

Sub-trip	Reason
1	No module was fitted previously
2	A module with the same identifier is fitted, but the set-up menu for this option slot has been changed, and so default parameters have been loaded for this menu.
3	A module with the same identifier is fitted, but the applications menu for this option slot has been changed, and so default parameters have been loaded for this menu.
4	A module with the same identifier is fitted, but the set-up and applications menu for this option slot have been changed, and so default parameters have been loaded for these menus.
>99	Shows the identifier of the module previously fitted.

Recommended actions:

- Turn off the power, ensure the correct option modules are installed in the correct option slots and re-apply the power.
- Confirm that the currently installed option module is correct, ensure option module parameters are set correctly and perform a user save in Pr *mm.000*.

Trip	Slot4 Error
Value	252
Short description	

The option module in option slot 4 has indicated an error. The option module can give the reason for the error and this is shown in the sub-trip number. As default the sub-trip number is shown as a number on the display, however, it is possible for the option module to supply sub-trip number strings which will be displayed instead of the number if available.

Recommended actions:

- See relevant *Option Module User Guide* for details of the trip.

Trip	Slot4 HF
Value	250
Short description	

This trip indicates that there is a fault with the option module in option slot 4 that means that this module cannot operate. The possible causes of the trip are given by the sub-trip value.

Sub-trip	Reason
1	The module category cannot be identified
2	All the required customisable menu table information has not been supplied or the tables supplied are corrupt
3	There is insufficient memory available to allocate the comms buffers for this module.
4	The module has not indicated that it is running correctly during drive power-up
5	The module has been removed after power-up or it has ceased to indicate to the drive processor that it is still active.
6	The module has not indicated that it has stopped accessing drive parameters during a drive mode change
7	The module has failed to acknowledge that a request has been made to reset the drive processor.
8	The drive failed to read correctly the menu table from the module during drive power-up.
9	The drive failed to upload menu tables from the module and timed-out (5s).
10	Menu table CRC invalid.

Recommended actions:

- Ensure the option module is installed correctly.
- Replace the option module.
- Replace the drive.

Trip	Slot4 Not Fitted
Value	253
Short description	

Each option module fitted in the drive is identified at power-up and the option fitted is stored by the drive in its non-volatile memory. If an option module was fitted in slot 4 at power-down, but that option module has subsequently been removed before power up then this trip is produced. The sub-trip number gives the identification code of the option module that has been removed. The priority order for the option module not fitted trips is *Slot1 Not Fitted* highest, then *Slot2 Not Fitted*, then *Slot3 Not Fitted* then *Slot4 Not Fitted*. Drive user parameters must be saved to prevent this trip on the next power-up.

Recommended actions:

- Ensure the option module is installed correctly.
- Re-install the option module.
- To confirm that the removed option module is no longer required perform a save function in Pr *mm.000*.

Trip	Slot4 Watchdog
Value	251
Short description	

This trip indicates that the option module in option slot 4 has started the option watchdog function and then failed to service this watchdog correctly.

Recommended actions:

- Replace the option module.

Trip	Slot App Menu
Value	216
Short description	

This trip indicates that more than one option slot has requested to customize application menus 18, 19 and 20. The sub-trip number indicates which option slot has been allowed to customize the menus.

Recommended actions:

- Ensure that only one of the Application modules is configured to customize the application menus 18, 19 and 20.

Trip	Soft Start
Value	226
Short description	

This trip indicates that the soft start relay in the drive has failed to close or the soft start monitoring circuit has failed.

Recommended actions:

- Hardware fault - contact the supplier of the drive.

Trip	Stored HF
Value	221
Short description	

If an HF01 to HF19 trip occurs then a *Stored HF* trip occurs each time the drive is powered up until this trip is reset. The sub-trip code is the number of the original HF trip. The *Stored HF* trip can only be reset by first writing 1299 to Pr *mm.000* and resetting the drive.

Recommended actions:

- Enter 1299 into Pr *mm.000* and press reset to clear the trip.

Trip	Sub-array RAM
Value	227
Short description	

An option module, derivative image or user program image has requested more parameter RAM than is allowed. The RAM allocation is checked in order of resulting sub-trip numbers, and so the failure with the highest sub-trip number is given. The sub-trip is calculated as (parameter size x 1000) + (parameter type x 100) + sub-array number. Note that if this trip occurs, all menu customisation provided by option modules, the derivative image or the user program image is not used. The tables below show the values corresponding to the parts of the sub-trip number.

Parameter size	Value
1 bit	1
8 bit	2
16 bit	3
32 bit	4
64 bit	5

Parameter type	Value
Volatile	0
User save	1
Power-down save	2

Sub-array	Menus	Value
Applications menus	18-20	1
Derivative image	29	2
User program image	30	3
Option slot 1 set-up	15	4
Option slot 1 applications	25	5
Option slot 2 set-up	16	6
Option slot 2 applications	26	7
Option slot 3 set-up	17	8
Option slot 3 applications	27	9
Option slot 4 set-up	24	10
Option slot 4 applications	28	11

Trip	<i>Temp Feedback</i>
Value	218
Short description	

This trip indicates a fault with a thermistor in the drive (i.e. open circuit or short circuit).

Source	xx	y	zz
Control board	00	00	01: Control board thermistor 1 02: Control board thermistor 2 03: I/O board thermistor:
Power system	Power module number	0	Zero for temperature feedback provided via power system comms. 21, 22 and 23 for direct ELV temperature feedback.
Power system	01	Rectifier number*	Always zero

*For a parallel power-module system the rectifier number will be one as it is not possible to determine which rectifier has detected the fault.

Recommended actions:

- Hardware fault - contact the supplier of the drive.

Trip	<i>Th Brake Res</i>
Value	10
Short description	

If hardware based braking resistor thermal monitoring is provided and the resistor overheats this trip is initiated. If the braking resistor is not present then this trip must be disabled with bit 3 of *Action On Trip Detection* (10.037) to prevent this trip.

Recommended actions:

- Check braking resistor wiring.
- Check braking resistor value is greater than or equal to the minimum resistance value.
- Check braking resistor insulation.

Trip	<i>Th Short Circuit</i>
Value	25
Short description	

This trip indicates that a temperature sensor connected to an analogue input or terminal 15 on the position feedback interface has a low impedance (i.e. < 50 Ohms). The cause of the trip can be identified by the sub-trip number.

Sub-trip	Source
1	Analogue input 1
2	Analogue input 2
3	Analogue input 3
4	Position feedback interface

Recommended actions:

- Check temperature feedback connection.
- Replace sensor.

Trip	<i>Thermistor</i>
Value	24
Short description	

This trip indicates that a temperature sensor connected to one of the analogue inputs or terminal 15 on the position feedback interface (15 way D-type connector) has indicated an over-temperature. The source of the trip can be identified by the sub-trip number.

Sub-trip	Source
1	Analogue input 1
2	Analogue input 2
3	Analogue input 3
4	Position feedback interface

Recommended actions:

- Check why the temperature measured by the sensor is too high temperature.
- Check temperature sensor connection.

Trip	<i>Undefined</i>
Value	110
Short description	

This trip indicates that the power system has generated but did not identify the trip from the power system. The cause of the trip is unknown.

Recommended actions:

- Hardware fault - contact the supplier of the drive.

Trip	<i>User 24V</i>
Value	91
Short description	

This trip is initiated if *User Supply Select* (06.072) = 1 or *Low Under Voltage Threshold Select* (06.067) = 1 or *Backup Supply Mode Enable* (06.068) = 1 and no user 24V present on the user 24V input.

Recommended actions:

- Ensure that the user 24V supply is present on the control terminals.

Trip	<i>User Prog Trip</i>
Value	96
Short description	

This trip can be initiated from within an onboard user program using a function call which defines the sub-trip number.

Recommended actions:

- Check the user program.

Trip	<i>User Program</i>
Value	249
Short description	

An error has been detected in the onboard user program image. The sub-trip indicated the reason for the trip.

Sub-trip	Reason	Comments
1	Divide by zero	
2	Undefined trip	
3	Attempted fast parameter access set-up with non-existent parameter	
4	Attempted access to non-existent parameter	
5	Attempted write to read-only parameter	
6	Attempted an over-range write	
7	Attempted read from write-only parameter	
30	The image has failed because either its CRC is incorrect, or there are less than 6 bytes in the image or the image header version is less than 5.	Occurs when the drive powers-up or the image is programmed. The image tasks will not run.
31	The image requires more RAM for heap and stack than can be provided by the drive.	As 30.
32	The image requires an OS function call that is higher than the maximum allowed.	As 30.
33	The ID code within the image is not valid	As 30.
40	The timed task has not completed in time and has been suspended.	<i>Onboard User Program: Enable (11.047)</i> is reset to zero when the trip is initiated.
41	Undefined function called, i.e. a function in the host system vector table that has not been assigned.	As 40.
52	Customisable menu table CRC check failed	As 30.
53	Customisable menu table changed	Occurs when the drive powers-up or the image is programmed and the table has changed. Defaults are loaded for the user program menu and the trip will keep occurring until drive parameters are saved.
80	*Image is not compatible with the control board	Initiated from within the image code.
81	*Image is not compatible with the control board serial number	As 80.
100	Image has detected and prevented attempted pointer access outside of the IEC task's heap area.	

101	Image has detected and prevented misaligned pointer usage.	
102	Image has detected an array bounds violation and prevented its access.	
103	Image has attempted to convert a data type to or from an unknown data type, has failed and has shut itself down.	
104	Image has attempted to use an unknown user service function.	
200	User program has invoked a "divide" service with a denominator of zero. (Note that this is raised by the downloaded image and has therefore been given a distinct error code despite being the same fundamental problem as sub-trip 1.)	
201	Parameter access is not supported. An attempt to read database other than the host drive.	
202	Parameter does not exist. Database was host drive but the specified parameter does not exist.	
203	Parameter is read-only.	
204	Parameter is write-only.	
205	Unknown parameter error.	
206	Invalid bit present in parameter. The parameter does not contain the specified bit.	
207	Parameter format lookup failed. Failed to get parameter information data.	
208	An over-range write has been attempted.	

The following table gives the differences when compared to the derivative product image.

Sub-trip	Difference
40, 41	<i>Onboard User Program: Enable (11.047)</i> is reset to zero when the trip is initiated.
51	Not applicable as core menu customisation not allowed
6x	Not applicable as option module restrictions not allowed
7x	Not applicable as option module restrictions not allowed
100	Image has detected and prevented attempted pointer access outside of the IEC task's heap area.
101	Image has detected and prevented misaligned pointer usage.
102	Image has detected an array bounds violation and prevented its access.
103	Image has attempted to convert a data type to or from an unknown data type, has failed and has shut itself down.
104	Image has attempted to use an unknown user service function.
200	User program has invoked a "divide" service with a denominator of zero. (Note that this is raised by the downloaded image and has therefore been given a distinct error code despite being the same fundamental problem as sub-trip 1.)

Trip	User Save
Value	36
Short description	

This trip indicates that an error has been detected in the user save parameters saved in non-volatile memory. For example, following a user save command, if the power to the drive was removed when the user parameters were being saved.

Recommended actions:

- Perform a user save in Pr *mm.000* to ensure that the trip doesn't occur the next time the drive is powered up.
- Ensure that the drive has enough time to complete the save before removing the power to the drive.

Trip	User Trip 40
Value	40
Short description	

This trip is not used by the drive and can be used for a user trip.

Trip	User Trip 41
Value	41
Short description	

This trip is not used by the drive and can be used for a user trip.

Trip	User Trip 42
Value	42
Short description	

This trip is not used by the drive and can be used for a user trip.

Trip	User Trip 43
Value	43
Short description	

This trip is not used by the drive and can be used for a user trip.

Trip	User Trip 44
Value	44
Short description	

This trip is not used by the drive and can be used for a user trip.

Trip	User Trip 45
Value	45
Short description	

This trip is not used by the drive and can be used for a user trip.

Trip	User Trip 46
Value	46
Short description	

This trip is not used by the drive and can be used for a user trip.

Trip	User Trip 47
Value	47
Short description	

This trip is not used by the drive and can be used for a user trip.

Trip	User Trip 48
Value	48
Short description	

This trip is not used by the drive and can be used for a user trip.

Trip	User Trip 49
Value	49
Short description	

This trip is not used by the drive and can be used for a user trip.

Trip	User Trip 50
Value	50
Short description	

This trip is not used by the drive and can be used for a user trip.

Trip	User Trip 51
Value	51
Short description	

This trip is not used by the drive and can be used for a user trip.

Trip	User Trip 52
Value	52
Short description	

This trip is not used by the drive and can be used for a user trip.

Trip	User Trip 53
Value	53
Short description	

This trip is not used by the drive and can be used for a user trip.

Trip	User Trip 54
Value	54
Short description	

This trip is not used by the drive and can be used for a user trip.

Trip	User Trip 55
Value	55
Short description	

This trip is not used by the drive and can be used for a user trip.

Trip	User Trip 56
Value	56
Short description	

This trip is not used by the drive and can be used for a user trip.

Trip	User Trip 57
Value	57
Short description	

This trip is not used by the drive and can be used for a user trip.

Trip	User Trip 58
Value	58
Short description	

This trip is not used by the drive and can be used for a user trip.

Trip	User Trip 59
Value	59
Short description	

This trip is not used by the drive and can be used for a user trip.

Trip	User Trip 60
Value	60
Short description	

This trip is not used by the drive and can be used for a user trip.

Trip	User Trip 61
Value	61
Short description	

This trip is not used by the drive and can be used for a user trip.

Trip	User Trip 62
Value	62
Short description	

This trip is not used by the drive and can be used for a user trip.

Trip	User Trip 63
Value	63
Short description	

This trip is not used by the drive and can be used for a user trip.

Trip	User Trip 64
Value	64
Short description	

This trip is not used by the drive and can be used for a user trip.

Trip	User Trip 65
Value	65
Short description	

This trip is not used by the drive and can be used for a user trip.

Trip	User Trip 66
Value	66
Short description	

This trip is not used by the drive and can be used for a user trip.

Trip	User Trip 67
Value	67
Short description	

This trip is not used by the drive and can be used for a user trip.

Trip	User Trip 68
Value	68
Short description	

This trip is not used by the drive and can be used for a user trip.

Trip	User Trip 69
Value	69
Short description	

This trip is not used by the drive and can be used for a user trip.

Trip	User Trip 70
Value	70
Short description	

This trip is not used by the drive and can be used for a user trip.

Trip	User Trip 71
Value	71
Short description	

This trip is not used by the drive and can be used for a user trip.

Trip	User Trip 72
Value	72
Short description	

This trip is not used by the drive and can be used for a user trip.

Trip	User Trip 73
Value	73
Short description	

This trip is not used by the drive and can be used for a user trip.

Trip	User Trip 74
Value	74
Short description	

This trip is not used by the drive and can be used for a user trip.

Trip	User Trip 75
Value	75
Short description	

This trip is not used by the drive and can be used for a user trip.

Trip	User Trip 76
Value	76
Short description	

This trip is not used by the drive and can be used for a user trip.

Trip	User Trip 77
Value	77
Short description	

This trip is not used by the drive and can be used for a user trip.

Trip	User Trip 78
Value	78
Short description	

This trip is not used by the drive and can be used for a user trip.

Trip	User Trip 79
Value	79
Short description	

This trip is not used by the drive and can be used for a user trip.

Trip	User Trip 80
Value	80
Short description	

This trip is not used by the drive and can be used for a user trip.

Trip	User Trip 81
Value	81
Short description	

This trip is not used by the drive and can be used for a user trip.

Trip	User Trip 82
Value	82
Short description	

This trip is not used by the drive and can be used for a user trip.

Trip	User Trip 83
Value	83
Short description	

This trip is not used by the drive and can be used for a user trip.

Trip	User Trip 84
Value	84
Short description	

This trip is not used by the drive and can be used for a user trip.

Trip	User Trip 85
Value	85
Short description	

This trip is not used by the drive and can be used for a user trip.

Trip	User Trip 86
Value	86
Short description	

This trip is not used by the drive and can be used for a user trip.

Trip	User Trip 87
Value	87
Short description	

This trip is not used by the drive and can be used for a user trip.

Trip	User Trip 88
Value	88
Short description	

This trip is not used by the drive and can be used for a user trip.

Trip	User Trip 89
Value	89
Short description	

This trip is not used by the drive and can be used for a user trip.

Trip	User Trip 112
Value	112
Short description	

This trip is not used by the drive and can be used for a user trip.

Trip	User Trip 113
Value	113
Short description	

This trip is not used by the drive and can be used for a user trip.

Trip	User Trip 114
Value	114
Short description	

This trip is not used by the drive and can be used for a user trip.

Trip	User Trip 115
Value	115
Short description	

This trip is not used by the drive and can be used for a user trip.

Trip	User Trip 116
Value	116
Short description	

This trip is not used by the drive and can be used for a user trip.

Trip	User Trip 117
Value	117
Short description	

This trip is not used by the drive and can be used for a user trip.

Trip	User Trip 118
Value	118
Short description	

This trip is not used by the drive and can be used for a user trip.

Trip	User Trip 119
Value	119
Short description	

This trip is not used by the drive and can be used for a user trip.

Trip	User Trip 120
Value	120
Short description	

This trip is not used by the drive and can be used for a user trip.

Trip	User Trip 121
Value	121
Short description	

This trip is not used by the drive and can be used for a user trip.

Trip	User Trip 122
Value	122
Short description	

This trip is not used by the drive and can be used for a user trip.

Trip	User Trip 123
Value	123
Short description	

This trip is not used by the drive and can be used for a user trip.

Trip	User Trip 124
Value	124
Short description	

This trip is not used by the drive and can be used for a user trip.

Trip	User Trip 125
Value	125
Short description	

This trip is not used by the drive and can be used for a user trip.

Trip	User Trip 126
Value	126
Short description	

This trip is not used by the drive and can be used for a user trip.

Trip	User Trip 127
Value	127
Short description	

This trip is not used by the drive and can be used for a user trip.

Trip	User Trip 128
Value	128
Short description	

This trip is not used by the drive and can be used for a user trip.

Trip	User Trip 129
Value	129
Short description	

This trip is not used by the drive and can be used for a user trip.

Trip	User Trip 130
Value	130
Short description	

This trip is not used by the drive and can be used for a user trip.

Trip	User Trip 131
Value	131
Short description	

This trip is not used by the drive and can be used for a user trip.

Trip	User Trip 132
Value	132
Short description	

This trip is not used by the drive and can be used for a user trip.

Trip	User Trip 133
Value	133
Short description	

This trip is not used by the drive and can be used for a user trip.

Trip	User Trip 134
Value	134
Short description	

This trip is not used by the drive and can be used for a user trip.

Trip	User Trip 135
Value	135
Short description	

This trip is not used by the drive and can be used for a user trip.

Trip	User Trip 136
Value	136
Short description	

This trip is not used by the drive and can be used for a user trip.

Trip	User Trip 137
Value	137
Short description	

This trip is not used by the drive and can be used for a user trip.

Trip	User Trip 138
Value	138
Short description	

This trip is not used by the drive and can be used for a user trip.

Trip	User Trip 139
Value	139
Short description	

This trip is not used by the drive and can be used for a user trip.

Trip	User Trip 140
Value	140
Short description	

This trip is not used by the drive and can be used for a user trip.

Trip	User Trip 141
Value	141
Short description	

This trip is not used by the drive and can be used for a user trip.

Trip	User Trip 142
Value	142
Short description	

This trip is not used by the drive and can be used for a user trip.

Trip	User Trip 143
Value	143
Short description	

This trip is not used by the drive and can be used for a user trip.

Trip	User Trip 144
Value	144
Short description	

This trip is not used by the drive and can be used for a user trip.

Trip	User Trip 145
Value	145
Short description	

This trip is not used by the drive and can be used for a user trip.

Trip	User Trip 146
Value	146
Short description	

This trip is not used by the drive and can be used for a user trip.

Trip	User Trip 147
Value	147
Short description	

This trip is not used by the drive and can be used for a user trip.

Trip	User Trip 148
Value	148
Short description	

This trip is not used by the drive and can be used for a user trip.

Trip	User Trip 149
Value	149
Short description	

This trip is not used by the drive and can be used for a user trip.

Trip	User Trip 150
Value	150
Short description	

This trip is not used by the drive and can be used for a user trip.

Trip	User Trip 151
Value	151
Short description	

This trip is not used by the drive and can be used for a user trip.

Trip	User Trip 152
Value	152
Short description	

This trip is not used by the drive and can be used for a user trip.

Trip	User Trip 153
Value	153
Short description	

This trip is not used by the drive and can be used for a user trip.

Trip	User Trip 154
Value	154
Short description	

This trip is not used by the drive and can be used for a user trip.

Trip	User Trip 155
Value	155
Short description	

This trip is not used by the drive and can be used for a user trip.

Trip	User Trip 156
Value	156
Short description	

This trip is not used by the drive and can be used for a user trip.

Trip	User Trip 157
Value	157
Short description	

This trip is not used by the drive and can be used for a user trip.

Trip	User Trip 158
Value	158
Short description	

This trip is not used by the drive and can be used for a user trip.

Trip	User Trip 159
Value	159
Short description	

This trip is not used by the drive and can be used for a user trip.

Trip	Voltage Range
Value	169
Short description	

This trip is initiated if the *Regen Minimum Voltage* (03.026) is set to a non-zero value and the supply voltage is outside the range defined by *Regen Maximum Voltage* (03.027) for more than 100ms.

Recommended actions:

- Ensure the supply voltage is operating within the drive specification.
- Ensure *Regen Minimum Voltage* (03.026) and *Regen Maximum Voltage* (03.027) are set correctly.
- Check the supply voltage waveform using an oscilloscope.
- Reduce the level of supply disturbance.
- Set *Regen Maximum Voltage* (03.027) to zero to disable this trip.

Trip	Watchdog
Value	30
Short description	

This trip indicates that the control word watchdog has been enabled and has timed out.